

Operating Instructions Arc Welding Robot Controllers

Model No. **YA-1W/YA-1Z/YA-2E/YA-2G Series**



Model No.

YA-1WAR61T**
YA-1WAR61Y**
YA-1WAR61E**
YA-1WAR61U**
(TM-1400/TM-1100/TM-1600)

YA-1WAR81T**
YA-1WAR81Y**
YA-1WAR81E**
YA-1WAR81U**
(TM-1800/TM-2000)

YA-1ZAR81T**
YA-1ZAR81Y**
YA-1ZAR81E**
YA-1ZAR81U**
(TL-1800/TL-2000)

YA-2EAR81T**
YA-2EAR81Y**
YA-2EAR81E**
YA-2EAR81U**
(TS-800/TS-950)

YA-2GA261T**
YA-2GA261Y**
YA-2GA261E**
YA-2GA261U**
(LA-1800)

TAWERS
The Arc Welding Robotic System

- Before operating this product, please read the instructions carefully and save this manual for future use. Please read the operating instructions of peripheral equipment together with it.
- First of all, please read "Safety precautions".

English version is the original instructions.

OM1303030EAE01

◆ Introduction

Thank you for purchasing our Panasonic arc welding robot TAWERS series. This manual is the Operating Instructions of TAWERS series controllers.

For operation of the controller, please refer to the operating instructions of "Teach Pendant for Arc Welding Industrial Robots". For handling of the manipulator, please refer to the operating instruction of the applied manipulator.

◆ For Your Safety

- Please read and understand separately provided "Safety Manual" thoroughly for proper and safe operation of our robots.
- Prior to operation, read this manual for proper operation. Keep this manual in an easily accessible place and re-read as necessary.
- The installation shall be made by qualified installation personnel and should conform to all national and local codes.
- Only qualified service personnel may install or service the robot system.
- Ensure compliance with all local and national safety and electrical codes for the installation and operation of the robot system.

◆ Registered trade mark

- Microsoft Windows and Windows CE are registered trade marks of Microsoft corporation in the United States and/or other countries.
- Other names of company and products are generally trade marks or registered trade marks of each company.

◆ Disclaimer

Our company and its affiliates (including any subcontractor, sales company or agent) shall not assume or undertake any responsibility or liability of the followings:

- Any problem arising out of, or directly or indirectly attributable to, the failure of user to carry out those normal installation, normal maintenance, normal adjustment and periodical check of this Product.
- Any problem arising out of any Force Majeure, including but not limited to, act of God.
- Any malfunction or defect of this Product that is directly or indirectly the result of any malfunction or defect of one or more related parts or products that are not supplied by our company. Or any problem arising out of, or directly or indirectly attributable to, the combination of this Product with any other product, equipment, devices or software that is not supplied by our company.
- Any problem arising out of, or directly or indirectly attributable to, user's failure to strictly carry out or follow all of the conditions and instructions contained in this instruction manual, or user's misuse, mishandle, operational miss or abnormal operation.
- Any problem arising out of this Product or the use of it, the cause of which is other than the foregoing but is also not attributable to our company.
- Any claim of a third party that this Product infringes the intellectual property rights of such third party that are directly or indirectly caused by User's use of this Product and relate to the method of production.

ANY LOST PROFITS OR SPECIAL, INDIRECT, INCIDENTAL OR CONSEQUENTIAL DAMAGES IN CONNECTION WITH OR ARISING FROM ANY MALFUNCTION, DEFECT OR OTHER PROBLEM OF THIS PRODUCT.

- This operating instructions manual is based on the information as of September, 2023.
- The information in this operating instructions manual is subject to change without notice.
- English version is the original instructions.

◆ Table of Contents





Introduction	2
1. Safety Precautions	4
1.1 Observe the following for safe welding operation.....	4
2. Specifications	7
2.1 About Model No.	7
2.1.1 Model group.....	7
2.1.2 Manipulator type	7
2.1.3 Example: Model number: YA-1WAR61Y007	
2.2 Technical data	8
2.2.1 Structure and control method	8
2.3 Inputs, outputs and communications ..	10
2.4 Specifications of digital welding	11
2.5 About static characteristic	12
2.6 Teach Pendant	13
2.7 Operation Box	14
2.8 Accessories for the controller	15
2.9 Connecting cable (Sold separately)	16
3. Transportation	17
3.1 Transportation methods.....	17
4. Installation	18
4.1 Choosing an installation site	18
4.2 Installation site.....	18
5. Connection	20
5.1 Connecting the controller to the manipulator	20
5.1.1 Connecting cable for the manipulator	20
5.1.2 Connecting cables for the built-in welding power source	21
5.1.3 Notes on using multiple robots	21
5.2 Connecting teach pendant	22
5.3 Connection of ground cable	23
5.3.1 Grounding	23
5.3.2 Connection of grounding wire	23
5.4 Connecting primary power source	24
5.4.1 Wiring primary power cable	24
5.4.2 Wiring primary cables (For T*/Y* specification)	25
5.4.3 Wiring primary cables (For E*/U* specification)	26
5.4.4 Using at 220 VAC (For T*/Y* specification).....	26
5.4.5 Door handle	28
5.4.6 Lock switches with padlock.....	29
5.5 Connecting and control method of external device	30
5.6 Using noise filter unit	31
6. Safety I/O Specifications	32
6.1 I/O for safety circuit	32
6.1.1 Spare emergency stop input.....	32
6.1.2 External emergency stop input	33
6.1.3 Door stop input.....	33
6.1.4 Protective stop 1 input	34
6.1.5 Protective stop 2 input	34
6.1.6 External enabling input	34
6.1.7 Input of the safety circuit	35
6.1.8 Emergency stop output.....	36
6.2 Other safety input/output	38
6.2.1 Safety holder input.....	38
6.2.2 Installation input.....	38
7. External Control Signal Connection	39
7.1 Terminal location of the sequencer card	39
7.2 Serial interface	40
7.3 I/O terminal equivalent circuit	41
7.4 Auto start settings	42
7.5 Status IN/OUT	42
7.5.1 Status INPUT	42
7.5.2 Status OUTPUT	43
7.5.3 Status I/O to be allocated to user terminals.....	43
7.6 Flowchart of Status Outputs	44
7.6.1 Operating and Holding output.....	44
7.6.2 Mode change (I/O monitor).....	44
7.6.3 Emergency stop 1	45
7.6.4 Emergency stop 2.....	45
7.6.5 Error output.....	46
7.7 Connecting to the sequencer card	46
7.8 External interface, External memory ...	47
7.8.1 SD Memory Card slot (Teach Pendant).....	47
7.8.2 USB port	47
7.8.3 SD Memory Card slot (Main CPU card).....	47
7.9 Welding voltage/current monitor	48
8. Maintenance and Inspection	49
8.1 Inspection schedule	49
8.2 Daily check	50
8.3 Periodical check	51
8.4 Precautions for withstand voltage test and insulation resistance measurement	52
9. Disposal of this product	53
10. Repair Parts List	54
10.1 Controller	54
10.2 Teach pendant	58
10.3 Operation Box	60
11. Critical Raw Material (CRM) List	61
12. Circuit Diagram	62
12.1 Controller 1	62
12.2 Controller 2	63
12.3 Welding power source	64
12.4 Welding power source	65
13. Label location	66
13.1 Location of labels	66
13.2 Labels	69

1. Safety Precautions

Please read the "Safety manual" (separate volume) for detail safe handling.

In case of using the product in a system, please also read the operating instructions of peripheral equipment.

◆ Signal Words and Safety Symbols

Signal Words		Safety Symbols	
 WARNING	Indicates a potentially hazardous situation, which, if not avoided, could result in death or serious injury.		Indicates a prohibited action.
 CAUTION	Indicates a potentially hazardous situation, which, if not avoided, could result in minor injury or property damage.		Indicates a mandatory action.
			Indicates a hazard alert.

1.1 Observe the following for safe welding operation

 **WARNING**

Welding Power Unit

 **Observe the following cautions to prevent accidents that can cause serious injuries.**

- (1) Never use the welding power unit for other than welding purpose, such as for pipe thawing.
- (2) It is very important to comply with all instructions, safety warnings, cautions and notes mentioned. Failure to do so can result in serious injury or even death.
- (3) Work of driving source at the input side, selecting work site, handling, storage and piping of high pressure gas, storage of welded products and also disposal of waste should be performed according to the operating instructions and national, state and local codes and regulations.
- (4) Prevent any unauthorized personnel to enter in and around the welding work area.
- (5) Only educated and/or skilled persons who well understand this welding power unit should install, operate, maintain and repair the unit.
- (6) Only educated and/or skilled persons who well understand the operating instructions of the unit and who are capable of safe handling should perform operation of the unit.

Against Electric Shock

 **Observe the following instructions to prevent the hazard.**

- (1) Only educated and/or skilled persons should perform grounding of the case of the welding power unit, the base metal and jigs electrically connected to the base metal.
- (2) Before installation or maintenance work, turn off all input power including power at the power distribution box and wait for at least five minutes to discharge electrical current from the capacitors. Check to make sure

that no charged voltage present at capacitors before touching any parts.

- (3) Do not use undersized, worn, damaged or bare wired cables.
- (4) Connect cables firm and insulate the connected parts.
- (5) Do not use the product with a case and panel removed or not in place.
- (6) Do not handle the welding power unit with torn or wet gloves.
- (7) Wear safety harness in case of working above floor level.
- (8) Perform periodic checks without fail. Repair or replace any damaged parts as needed prior to use.
- (9) Turn off all equipment when not in use.
- (10) Do not touch any live parts.
- (11) The welding power unit must be grounded and the work must be grounded in accordance with ANSI Z49.1 (For North America).

Electromagnetic Wave

 **Observe the following cautions to prevent radio interference due to welding current and high frequency for arc start.**

- (1) Electromagnetic wave generated during welding operation may have adverse affects on medical equipment in the periphery of the equipment in operation and the welding work site. If you wear a pacemaker, consult your physician before going near the welding work site.
- (2) Provide proper grounding work of all equipment including electronic devices and safety devices near the welding work site. Conduct an additional electromagnetic shielding work if needed.
- (3) Lay the welding cable as short as and as close to the floor or ground as possible. Lay the base metal cable and the torch cable along to each other to reduce generation of electromagnetic wave.
- (4) Never share the ground work of the base metal and welding power unit with other equipment.

WARNING

- (5) Provide measures against noise to the external equipment, such as sequencer of the jig, proximity switch and area sensor, if such equipment is affected by the inverter noise from the robot or welding power unit. For details of the measures, please refer to the operating instructions of the external equipment.

Ventilation and Protective Equipment



Oxygen deficit, fume and gas generated during welding can be hazardous.

- (1) Provide sufficient ventilation or wear breathing equipment specified by the applicable law (occupational safety and health regulation, ordinance on the prevention of oxygen deficiency and the like).
- (2) To prevent dust injury or poisoning by the fume generated during welding, use a local exhauster specified by the applicable law (occupational safety and health regulation, rules on preventing injury by inhaled dust or etc.) or wear a protective breathing gear. If a protective breathing gear is used, it is recommended to use one with an electric fan with high protection performance.
- (3) When conducting welding in the bottom, such as tank, boiler and the hold of a ship, use a local exhauster or wear breathing equipment specified by the applicable laws and regulations.
- (4) When conducting welding in a confined area, make sure to provide sufficient ventilation or wear breathing equipment and have a trained supervisor observe the workers.
- (5) Do not conduct welding at a site where degreasing, cleaning or spraying is performed. Conducting welding near the area where any of these types of work is performed can generate toxic gases.
- (6) When welding a coated steel plate, provide sufficient ventilation or wear protective breathing gear. (Welding of coated steel plates generates toxic fume and gas.)

- (7) Never ventilates with oxygen. Refer to ANSI Z49.1(For North America).

Against Fire, Explosion or Blowout



Observe the following cautions to prevent fires explosion or blowout.

- (1) Remove any flammable materials at and near the work site to prevent exposure of such flammable materials to the spatter. If they cannot be relocated, cover them with a fireproofing cover.
- (2) Do not conduct welding near flammable gases. Do not place the electric equipment near flammable gases, otherwise, such gases may catch fire from a spark of electricity inside the electric equipment.
- (3) Do not bring the hot base metal near flammable materials immediately after welding.
- (4) When welding a ceiling, floor or wall, remove all flammable including ones located in hidden places.
- (5) Connect cables firm and insulate the connected parts. Improper cable connections or touching of cables to any electric current passage of the base metal, such as steel beam, can cause fire.
- (6) Connect the base metal cable as close as possible to the welding section.
- (7) Do not weld a sealed tank or a pipe that contains gas.
- (8) Keep a fire extinguisher near the welding site for an emergency.

No Disassembling/Modification



Unauthorized disassembling or modification can cause fire, electric shock or breakdown.

- (1) Contact Panasonic sales representatives for repair work.
- (2) As for inspection of the inside the product if needed, follow the instructions in the operating instructions.

CAUTION

Installing Shielding (Curtain etc.)



Arc flash, flying spatter and slugs generated during welding can damage your eyes, skin and hearing.

- (1) When welding or monitoring welding operation, wear safety glasses with sufficient light blocking structure or use a protective mask designed for welding operation.
- (2) When welding or monitoring welding operation, wear protective clothing designed for welding operation, such as leather gloves, leg cover and leather apron, and also wear long-sleeve shirts.
- (3) Install a protective curtain around the welding operation site to prevent exposure of eyes of people in the surrounding area to the arc flash.
- (4) Be sure to wear noise-proof protective equipment, such as ear muffs and ear plugs, if the noise level is high.

Gas Cylinder and Gas Flow Regulator



Overturn of gas cylinder and blowout of gas flow regulator can cause injury.

- (1) The gas cylinder must be handled properly according to the applicable law and in-house standards.
- (2) Use the gas flow regulator that is supplied or recommended by our company.
- (3) Read the operating instructions of the gas regulator prior to use, and observe the cautions described in it.
- (4) Secure the gas cylinder to a dedicated gas cylinder stand.
- (5) Do not expose the gas cylinder to high temperature.
- (6) When opening the valve of the gas cylinder, do not bring your face close to the discharge outlet.
- (7) When the gas cylinder is not in use, be sure to put the protective cap back on.
- (8) Do not hang the welding torch on the gas cylinder. Do not allow the electrode to touch to the gas cylinder.
- (9) Only the specified contractor should perform disassembly or repair work on the gas flow regulator. Such works require some expertise.



CAUTION

Rotating Parts



Rotating parts can cause injury.

- (1) Keep away from rotating parts, such as cooling fans and feed rollers of the wire feeder, or hand, finger(s), hair or part of your clothes may be caught by the rotating parts resulting in injury.
- (2) Do not use the product with a case and panel removed or not in place.
- (3) Only educated and/or skilled persons who well understand welding machines should perform maintenance and repair work. During maintenance or repair work, provide fence or the like around the welding machine so that any unauthorized person can not come close to the working area carelessly.

Welding Wire



Welding wire, especially wire tip part can cause injury.

- (1) Do not perform inching operation or pull the torch switch with your eyes, face or body close to the end of the welding torch. Wire extends out from the end of the welding torch and may stick into the eye, face or body.

- (2) In case of using a torch cable with the resin liner, straighten the torch cable and reduce the preset feed amount (current) to half or less before applying the wire inching.
- (3) If the high speed wire inching is executed with the torch cable extremely-bended, the welding wire may pass through the resin liner and the cable. Replace any damaged liner/cable with a new one without fail. Never use a damaged liner/cable, or it can cause gas leak or insulation deterioration.

Against Insulation Deterioration



Insulation deterioration can cause fire of welding power unit.

- (1) Keep enough distance from welding power unit when performing welding or grinding operation so as to prevent such spatters or iron particles from getting into the power unit.
- (2) Perform inspection and maintenance work periodically so as to prevent insulation deterioration due to accumulated dust or dirt.
- (3) When spatters or iron particles get into the welding power unit, turn off the power switches of the welding power unit and power distribution box, and then use dry air to blow them off.

2. Specifications

2.1 About Model No.

Model number	Code number: Manipulator	Code number: Controller	Specifications
YA-1WAR61***	YA-1WMR61***	YA-1WCR61***	TAWERS (WGIII type controller)
YA-1WAR81***	YA-1WMR81***	YA-1WCR81***	
YA-1ZAR81***	YA-1ZMR81***	YA-1ZCR81***	
YA-2EAR81***	YA-2EMR81***	YA-2ECR81***	
YA-2GA261***	YA-2GM261***	YA-2GC261***	

Of the model number, "****" consists of one-letter "Model group" code followed by a "Manipulator type" code of two alphanumeric characters.

2.1.1 Model group

Model group code	Basic design policy
T	The robot is designed as standard specification for the use in Japanese market in general
Y	The robot is designed as standard specification for the use in overseas markets in general. <Note> If you are intended to use the robot in US, Canada or EU member states (including countries signed the EEA accord), please purchase the robot designed for those countries. (See the following models.)
E	The robot is designed in accordance with the following European directives, UK regulations and EN standards. EU directives : 2006/42/EC and 2014/30/EU. UK regulations : S.I. 2008/1597 and S.I. 2016/1091 EN standards : EN ISO 10218-1:2011, EN 60204-1:2018, EN IEC 60974-1:2018 +A1:2019, EN IEC 60974-5:2019, EN 61000-6-4:2007+A1:2011, EN 61000-6-2:2005 and EN 60974-10:2014+A1:2015. Before put into service the Robot in the European market the Robot system shall be designed in accordance with the manufacturers specification described in this manual and instruction manual. Remodeling and/or modifying this product not in accordance with the manufacturers specification then this declaration will lose its validity. Authorised Representative: Panasonic Connect Europe GmbH Panasonic Testing Centre Winsbergring 15, 22525 Hamburg, Germany
U	The robot is designed in accordance with the following safety regulations and standard applied in the US and Canadian markets. UL1740:2018 ANSI/RIA R15.06-2012 CAN/CSA Z434-14 Notice: Exporting the machine into Canada Please bear in mind that exporting this product to Quebec, Canada requires all name plates and manuals of the product shall be written in French.

Attention to the export of the product to EU member states and UK

Products other than E model group code do not meet the requirements specified in the EU Directives or UK regulations which are the EU and UK safety ordinance. Please bear in mind that those products may not be brought as is into the EU member state, any other country which has signed the EEA accord or UK.

2.1.2 Manipulator type

Please refer to the operating instructions of the manipulator.

2.1.3 Example: Model number: YA-1WAR61Y00

The model number "YA-1WAR61Y00" is a floor installation type manipulator for welding operation with standard arm (TM-1400WGIII) for overseas market in general.

Specifications

2.2 Technical data

2.2.1 Structure and control method

Item		Specifications
Structure and IP class		Closed box type, IP32 or equivalent
Cooling method		Indirect air cooling (Circulating internal air), Direct air cooling (Welding power supply)
Input power source		3-phase, 200 VAC \pm 20 VAC, 22 kVA(20 kW), 50/60 Hz \pm 2 % (T/Y specifications only: Switchable to 220 VAC.) Maximum current: 246 A/5.6 ms ^(*) (during servo ON)
Grounding		Protective Earth (PE) grounding is required. Functional Earth (FE) is required depending on applied system. Note) For Power capacity, see section "Connection".
Earth Leakage current		Less than 17 mA
Body color		Munsell color system 5Y8/1
Teaching method		Teaching playback
Path control		PTP and CP (Linear and circular interpolation)
The number of control axes		6 axes simultaneously (Max. 27 axes)
The number of external axes	Other than LA-1800	Limiting to manipulator + 3 built-in external axes (2 kW motor or smaller) + 6 exterior type axes (Total motor capacity: 20 kW or less)
	LA-1800	Limiting to manipulator + 3 built-in external axes (2 kW motor or smaller per axis, total motor capacity: 4 kW or less) + 6 exterior type axes (Total motor capacity: 20 kW or less)
Position detection method		Electronic type absolute pulse encoder
Position control method		Software servo control
Speed control method		Constant linear velocity control (during CP control)
Speed range	at teaching operation	Max. speed can be controlled within the safety speed range from 0.01 m/min to 15 m/min (Default setting: 15 m/min)
	at playback operation	0.01 m/min to 180 m/min (Direct input method)
Memory system		IC memory (Battery back-up system)
Memory capacity and software		See the operating instructions "Operation"
Connecting cable		Sold separately (See "2.9 Connecting cable (Sold separately)" on page 16.)
Dimensions (W x D x H)		553 x 550 x 1 181 (mm) (Protruding portions not included.)
Operating ambient temperature, humidity		0 to 40 °C, 20 to 90 %RH (50 % RH or less at 40 °C, and 90 %RH or less at 20 °C.) No due condensation
Transportation / Storage temperature		-25 °C to 60°C
Mass (Weight) (*2)	Other than LA-1800	135 kg (298 lb), (Excluding the Teach pendant and connecting cable.)
	LA-1800	140 kg (308 lb), (Excluding the Teach pendant and connecting cable.)

Note

For details of software and operation of the controller, please refer to the operating instruction [Operation].

(*1): If exterior type external axes are connected, the maximum power varies with the total motor capacity of the connected external axes (do not include built-in type external axes). The details are as follows.

(Total motor capacity)

- 10.5 kW or less: 246 A/ 5.6 ms
- Over 10.5 kW: 366 A/ 2 ms

(*2): For YA-**C***EM*, add 5 kg to each mass.

● Dimensions

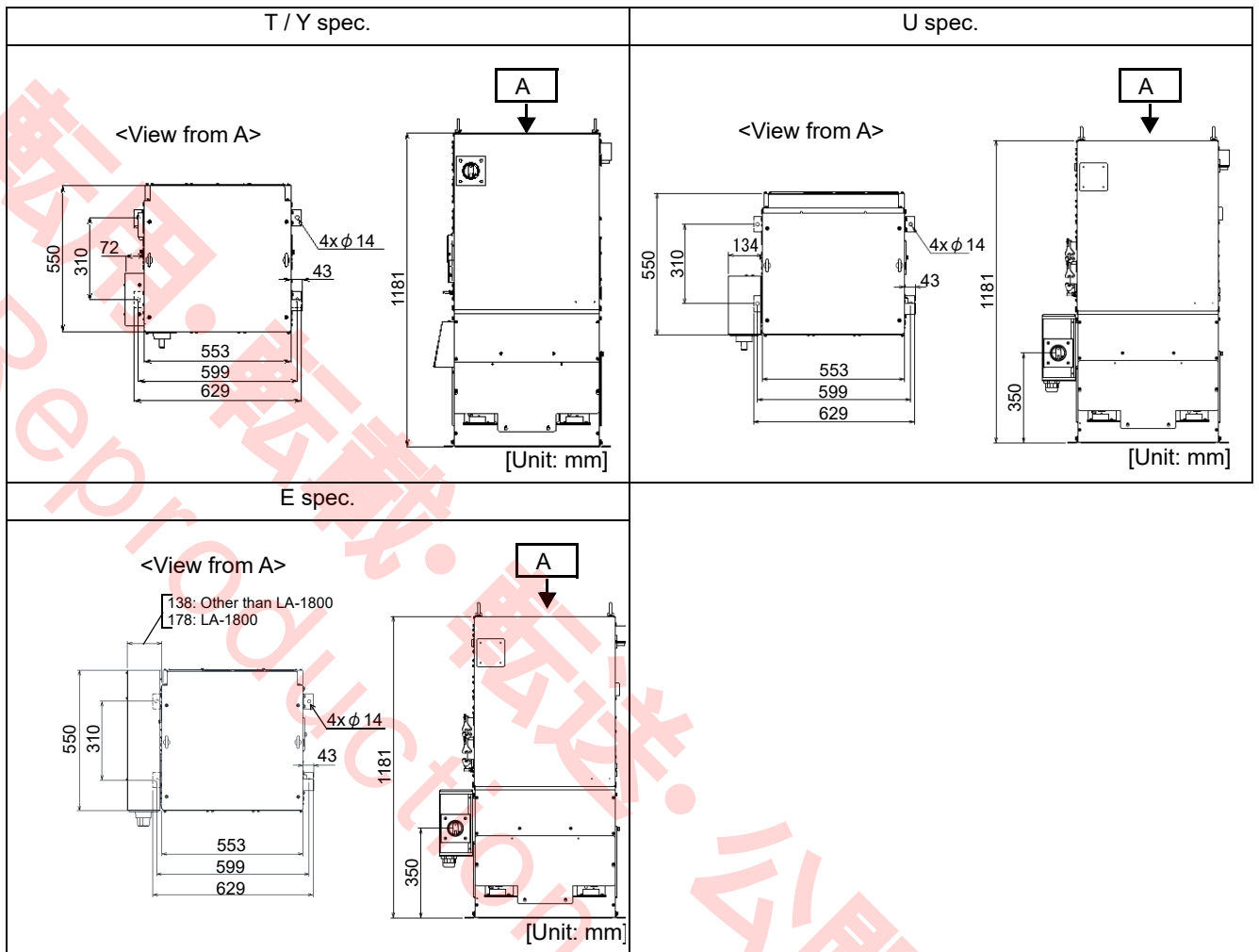

2.3 Inputs, outputs and communications

Items	Input and output	Specifications	
Status I/O	Input	1. Start 2. Hold 3. Error release 4. Teaching mode 5. Operating mode 6. Servo ON	
	Output	1. Running 2. Hold status 3. Error 4. Operating mode 5. Teaching mode 6. Servo ON 7. Ready 8. Alarm	
Common I/O	Input	40 points (Option: expandable to max. 2 048 points)	
	Output	40 points (Option: expandable to max. 2 048 points)	
	I/O allocation	Program select input, other status I/O.	
Other I/O	Input	Safety Holder input and Installation input	
	Input specs.	Photo-coupler (ON/OFF of 24 VDC, 12 mA)	
	Output specs.	T/Y/U spec.	Open collector (NPN)
		E spec.	Open collector (PNP)
Safety circuit	Dual circuit input	1. Emergency stop for Teach Pendant 2. Spare emergency stop 3. External emergency stop 4. Door stop 5. Enabling switch 6. External enabling switch 7. Panel emergency stop ^(*1) 8. Protective stop	
	Output	Emergency stop output (system 4)	
	Input specs.	Double contacts (Dual circuit)	
	Output specs,	Double contacts (Dual circuit)	
	External memory, Communication Interface	Controller	Optional RS-232C, RS-422 and Ethernet ^(*2)
	Teach Pendant	SD memory card slot USB2.0 (Hi-Speed not supported): 2 ports ^(*3)	

Note

Manipulator is not included in this product. Although some setting items/commands for the manipulator are displayed on the screen of the teach pendant while operating the teach pendant, those setting items or commands are not available.

^(*1): For controllers of E and U specifications, it is factory connected to the "Emergency stop" of the operation box (standard accessory).

^(*2): Connect only with LAN in the plant.

^(*3): Do not turn off the power switch while connecting with SD memory or USB memory.

2.4 Specifications of digital welding

Item	Specifications
Built-in welding power source type	YA-1TD351□** (*1)
Welding method	CO ₂ , MAG, Stainless steel MIG, Pulsed MAG/MIG
Control method	Inverter
Max. no-load voltage	65 VDC
Output current adjustable range	30 - 350 ADC
Output voltage adjustable range	12 - 36 VDC (12 - 42VDC : E type only)
Rated duty cycle (10 min. interval)	80 % for GMAW and 60 % for pulsed GMAW
Output terminal	Connection with M8 bolt and nut
Insulation level	Main transformer: Class F, Reactor: Class E, Power factor improvement reactor: Class H.
Mass	48 kg (106 lb)
Power efficiency	85 % (350 A/42 V : E type only)
Standby power consumption	10 W (welding power source only)
Equivalent models	None
Shield gas index at MAG welding	350 A: 20 L/min
Wire use rate	350 A: 134 g/min

(*1) □ shows Model group (T/E/U).

Note About "Duty cycle"

Duty cycles are based on a ten minutes time interval.

If the duty cycle is 80 % at rated output, that means for 80 percent of the ten-minute period (8 minutes), the welding power source can maintain operation at the rated welding current without overheating. The remaining two minutes must be operated at no-load to allow proper cooling. (8 min. / 10 min.) x 100 = 80 (%)

Using the machine at beyond the rated duty cycle causes rise in temperature of the machine beyond the max. allowable temperature, and deterioration or burning of the machine may be the result.

In case of using the machine in combination with other products, such as welding torch, please apply the lowest rated duty cycle among the applied products.

Duty cycle at 40 °C is calculated based on simulations.

(GMAW)

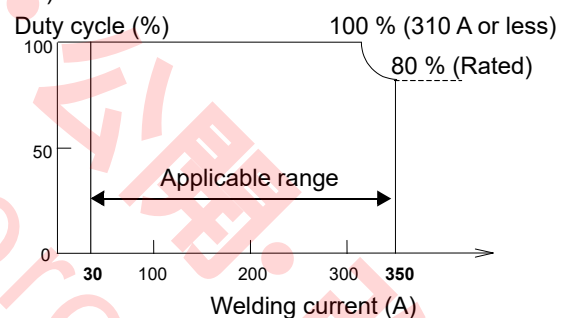

(Pulsed GMAW)

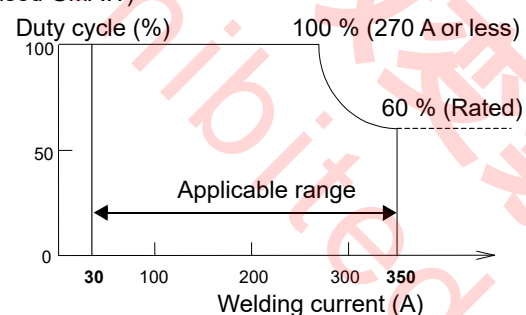

2.5 About static characteristic

The static characteristic of this welding power source is the following constant voltage characteristic.

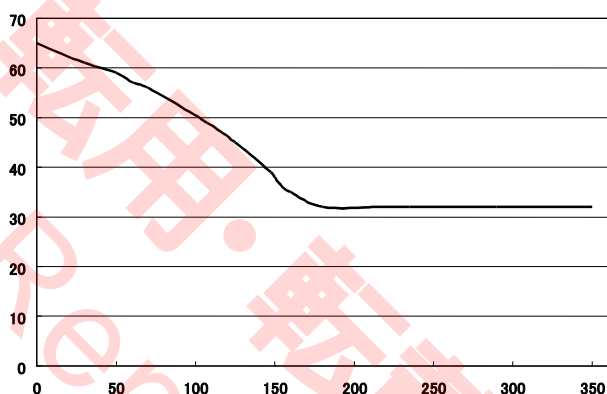

- Thermal protection

The welding power source is equipped with thermal switch at the radiator fin of the semiconductor to monitor the temperature.

The thermal switch is turned on and stops the output when the welding power source becomes an abnormal elevation of temperature due to over-duty cycle or over-rated output current, or declining cooling effect.

2.6 Teach Pendant

Item	Specifications	
Model number	AUR01060	WSAUR00002ZZ
Environmental protection class	IP42 or equivalent	
Display	7 inches wide TFT color graphic LCD	
Memory in TP	IC memory	
SD memory card slot	1 slot	
USB 2.0 port	2 (Hi-Speed: not supported), Bus power: 150 mA	
Enabling switch	3 points action	
Emergency stop switch	1 (Mechanical self-hold type)	
Connecting cable	10 m	
mass	988.5 g (Cables not included.)	

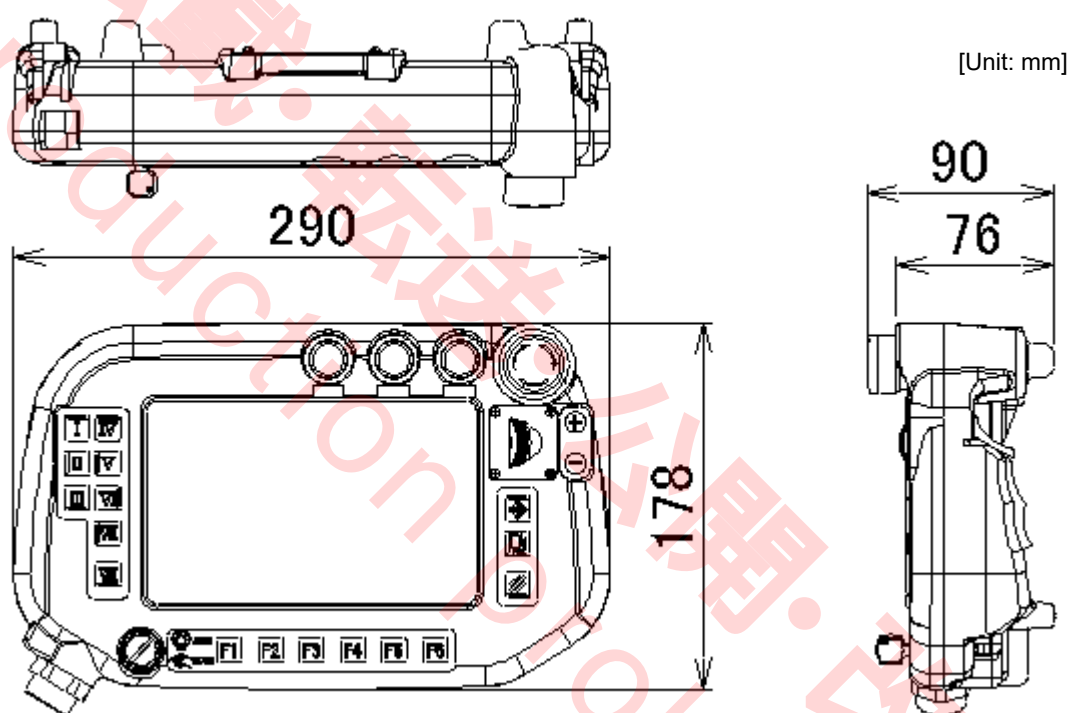

CAUTION

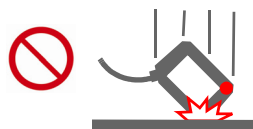

Careful not to drop the teach pendant.
Or it may result in teach pendant damage and/or injury.



Do not place anything on the teach pendant.
Do not apply any strong force or impact especially on the LCD part.
Or it may result in damage of teach pendant and LCD.

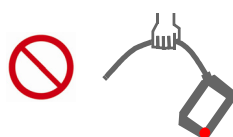

Do not pick up or handle the teach pendant by the cable or the connector part.
Hold the teach pendant by the body at any time.
Or excess load will be applied to the connection, which can damage the teach pendant.

Specifications

2.7 Operation Box

T / Y spec.	Optional
E / U spec.	Standard

Item	Specifications
Environmental protection class	IP40 or equivalent
"AUTO mode" switch	1 (Connect to the "PNL" connector of the sequencer card.)
Emergency stop switch	1 (Mechanical self-holding type. Connect to the "PNL" connector of the safety card.)
Software	If the operation box is purchased as an optional unit, the initial setup by our service engineer is needed.
Connecting cable	6 m

The "AUTO" mode operation is functioned by

- (1) Changing the Mode switch of the Teach Pendant to "AUTO"
- or
- (2) Restarting after door stop input in "AUTO" mode, and then the "AUTO mode" button of the Operation Box is pressed.

● Location of PNL connector

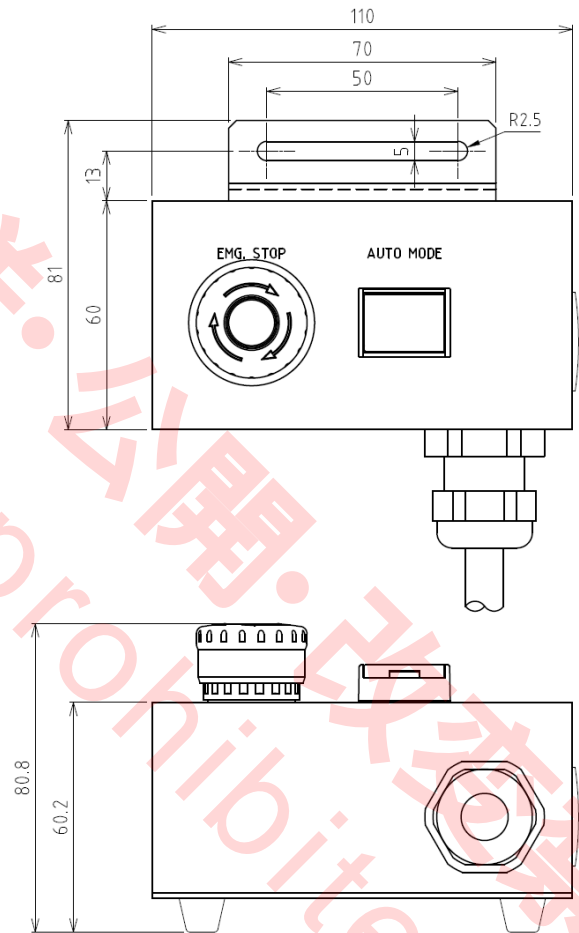
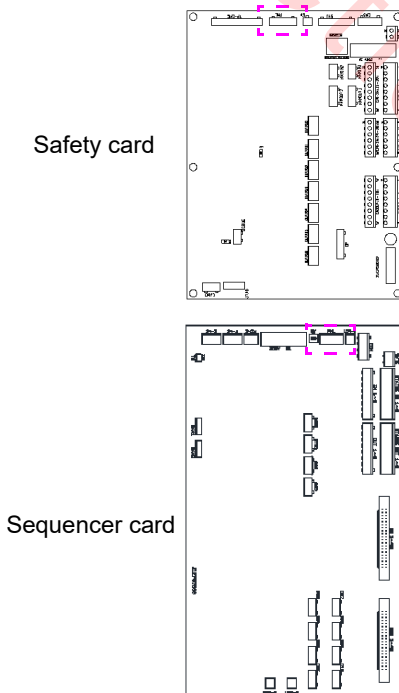

[Unit: mm]

Note

- Depending on the model numbers, the operation box is factory connected at shipment.
- If not connected, the "PNL" terminal of the safety card is factory short-circuited at shipment.

2.8 Accessories for the controller

Description		Part number	Repair parts order number	Q'ty	Note	Safety part
TP hook		AKC41237	AKC41237	1	For Teach Pendant	
Ball chain (*)		TM14-1L500	YAB47	1		
Mode select switch key (*)		AS6-SK-132	YAB178	1 set	2 pcs/set	
Fuse (12 A anti-rush type)		CES14-12AN2	YABD264	1		Yes
Fuse (8 A anti-rush type)		ST4-8AN1	YZAD217	2		Yes
Fuse (3 A anti-rush type)		ST4-3AN1	YZA/EEJ002	6		Yes
Fuse (5 A anti-rush type)		ST4-5AN1	YZAD183	1		Yes
Fuse (0.5 A anti-rush type)		ST4-0.5A	YZAD179	2		Yes
Fuse (15 A)	T / Y spec.	250VTLLC15A	YABD93	3		Yes
	E spec.	FNM15	YABD288	3		Yes
	U spec.	-	-	-	Not provided	Yes
Fastener key (For the front door lock)		(Fastener attachment)	-	2		
Connector (For the Sequencer card)		FCN361J040AU	FCN361J040AU	2		
Connector cover (For the Sequencer card)		FCN360C040B	FCN360C040B	2		
Harness (For external emergency stop and door stop)		AWC42038	AWC42038	4		
Label for Key switch (Sheet type)		ANS31017	ANS31017	1	Delivered in a plastic bag and tape it to the rear side of the teach pendant.	
Labels:(Matchmarks for origin)		ANU51519	ANU51519	1		
Terminal labels (For "User I/O")		ANS41119	ANS41119	1		
Saddle		SP30	SP30	1		
Rubber sheet		AFQ41158	AFQ41158	1		
Bolt		XVGZ8+F25FJ	YZA239	2		
Washer		XWE8FJ	YZA225	2		
Nut		XNG8GFJ	YZA198	2		
Noise suppression parts	Clamp filter	J0KG00000014	J0KG00000014	-		
	Nylon tie	AB150	YAW87	-		
	Tie fixture	TMS20	YWW39	-		

(*) : They are fitted with the TP hook.

Note

Safety parts are important for safe machine operation. Always use correct parts in correct locations.

Specifications

2.9 Connecting cable (Sold separately)

The cable connecting the manipulator and the controller is available separately. Prepare a cable of length suitable to the installation environment (position of the devices). The following shows details of our standard cable model.

Note

Cable length should be 1 m longer than the distance between the manipulator and the controller in consideration of the height of the controller at cabling.

Cable length	Part number	Specifications	Outside diameter	Bend radius at the time of installation
5 m	AWU03837L5M	For fixed wiring	23.6 mm	185 mm or more

Two pieces of ground cable; AWC42164LN (5 m in length, 14 mm² in sectional area (AWG6)) are included in the connecting cable unit.

● Flexing cable (Made-to-order)

Lay the cable on a place free from tension or twist to the cable.

Cable length	Part number	Specifications	Outside diameter	Bend radius in motion
5 m	AWU03866L5M	For mobile	24.6 mm	246 mm or more

Two pieces of ground cable; AWC42164LN (5 m in length, 14 mm² in sectional area (AWG6)) are included in the connecting cable unit.

Note

- For other cable lengths, please consult Panasonic representatives.
- Install manipulator and controller so that the distance between two is 30 m or shorter.

3. Transportation

3.1 Transportation methods



CAUTION

In case of using a crane, be sure not to stand under or near the lifted controller.
In case of using forklift, be sure no personnel shall hold the controller.

Any transportation method that may apply any shock to the controller shall be avoided.

- (1) Crane or forklift should be handled by qualified personnel.
- (2) In principle, use a crane to transport a controller for installation or re-installation. When a crane is used, hang the controller with double-wire through the attached two eyebolts as illustrated in the figure on the right.
 - Double-wire hanging method.
Hook the wires to the provided eyebolts.

About eyebolts

Eyebolts are important safety parts. When they are lost or broken, purchase Panasonic genuine eyebolts for your safety.

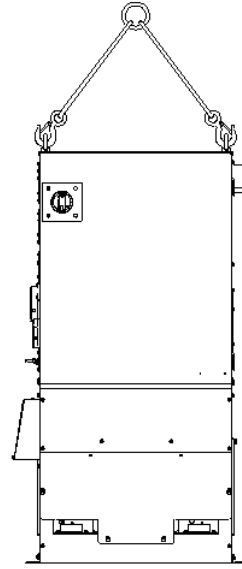

- (3) In case it is necessary to use folk lift for transportation, pack and fix the controller in the transportation package before moving it.

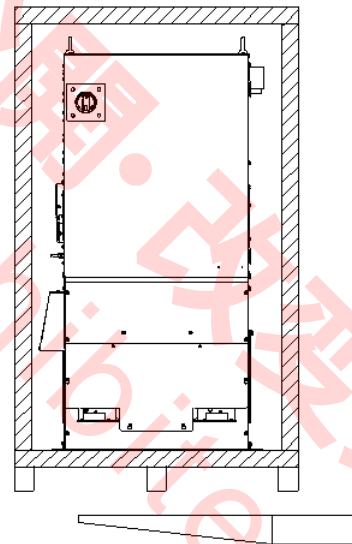

4. Installation

⚠ CAUTION

The installation shall be made by qualified installation personnel and should conform to all national and local codes.

4.1 Choosing an installation site

- Locate indoors with ambient temperature 0 °C to 40 °C.
- Avoid exposure to direct sun light or the rain or water spray.
- Humidity relative to temperature:
 - Up to 50 % at 40 °C
 - Up to 90 % at 20 °C
- Altitude above sea level: Up to 1000 m.
- Inclination to installation surface: Max. 10 degrees.
- Avoid wind to the arc (Provide windshields.)
- Free from abnormal amount of dust, acid, corrosive gases or substances etc. other than those generated by welding process.
- Avoid places where metallic substances or combustible foreign materials can get into the welder through the air inlets.

• IP code

Part	IP code
Controller body	IP32 or equivalent
Teach pendant	IP42 or equivalent
Operation Box	IP40 or equivalent

Note

- If a significant noise source (plasma or high frequency etc.) exists at or around the installation site, please consult us in advance.
- Refer to the environmental protection class (IP class) of each machine. (See “Specifications”).

4.2 Installation site

- (1) Locate the controller outside of the work envelope of a manipulator and also outside the safety fenced area. Make sure to maintain space from any wall or peripheral equipment (see the figure on the right) from any wall or peripheral equipment for maintenance and inspection work and to control temperature inside of the controller.

Note: Do not place anything above and below the controller unless otherwise specified.
 If places, an abnormal temperature error may occur due to increase in temperature inside the controller.

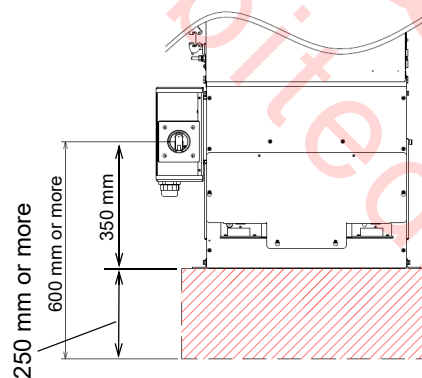
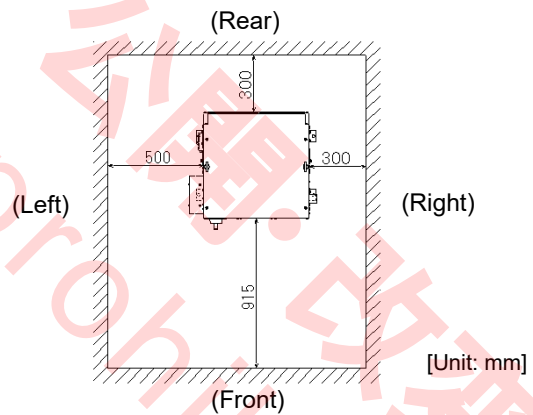

< E / U spec. >

Set a bedplate under the controller to give the controller lift from the floor so that the breaker is positioned at 600 mm or more above the floor.

(2) Installation method

Fix the fixing plates of the controller to the ground or bedplate with M12 anchor bolts.

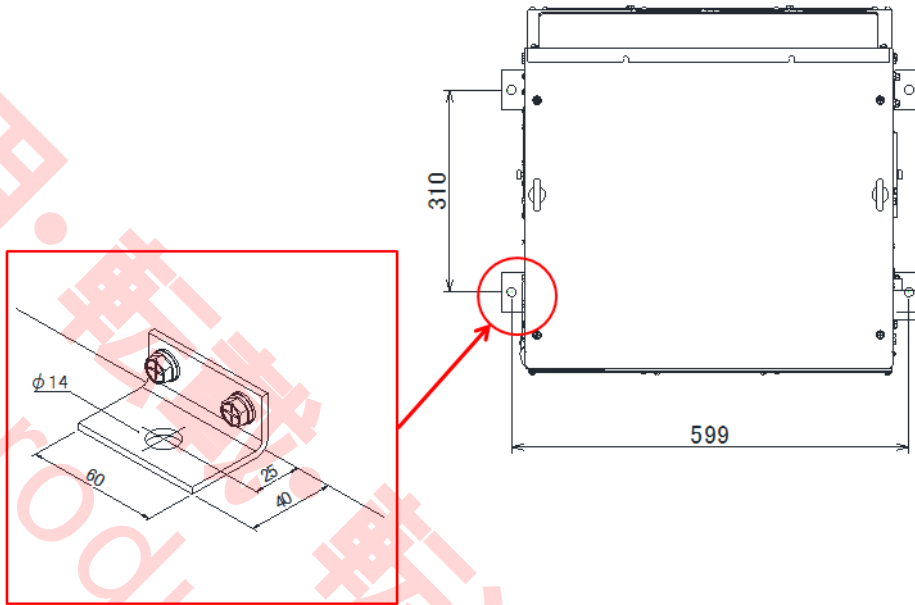

(3) Teach pendant

Hook the teach pendant on the provided TP hook. TP hook should be installed outside of both the safety fence and the work envelope of the manipulator so as to prevent possible danger due to mode change inside the safety fenced area. A mode switch key is chained with ball chain to the TP hook. Length of the cable between the teach pendant and the controller is 10 m.

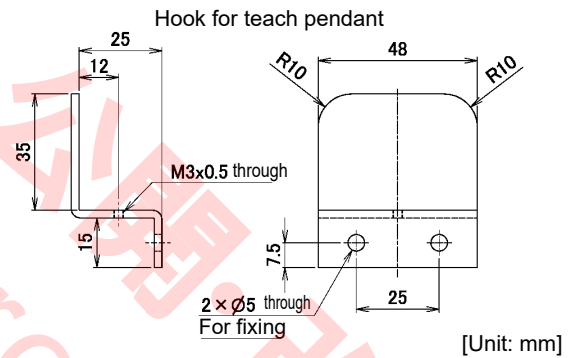

(4) Operation box

T / Y spec.	Optional
E / U spec.	Standard

The panel fixture is provided with the operation box to station the operation box during operation or to store it. To use the panel fixture, please prepare a hook at customers' end. Make sure to locate it outside of the work envelope of a manipulator and also outside the safety fenced area. It shall be placed where the operator can check inside of safe guard area easily. Length of the cable between the operation box and the controller is 6 m.

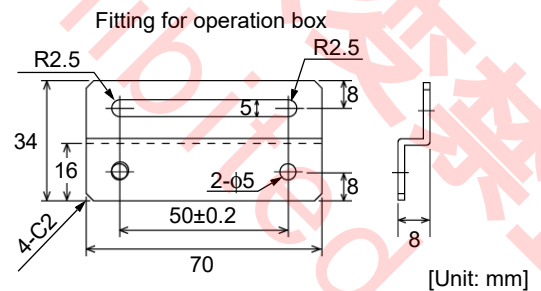

5. Connection

CAUTION

The installation shall be made by qualified installation personnel and should conform to all national and local codes.

5.1 Connecting the controller to the manipulator

5.1.1 Connecting cable for the manipulator

- (1) Connect the motor cable and RE cable to the connectors for controller and manipulator respectively. Make sure to push the cables until the gap between the connector and cable connector case becomes 1 mm or smaller.

< Note >

Wide gap between the plug and the receptacle may cause bent pin of the connector.

- (2) Push down the hook lever to the arrow direction and lock the plug.

Note

- Make sure to connect the controller to the manipulator of the same production number as the controller as the origin data of the manipulator (robot position control origin), which forms a pair with the controller is saved in the controller.
- Connecting cable is sold separately. Prepare a cable of length suitable to the installation environment (position of the devices). For details, please refer to section "2.9 Connecting cable (Sold separately)" on page 16.

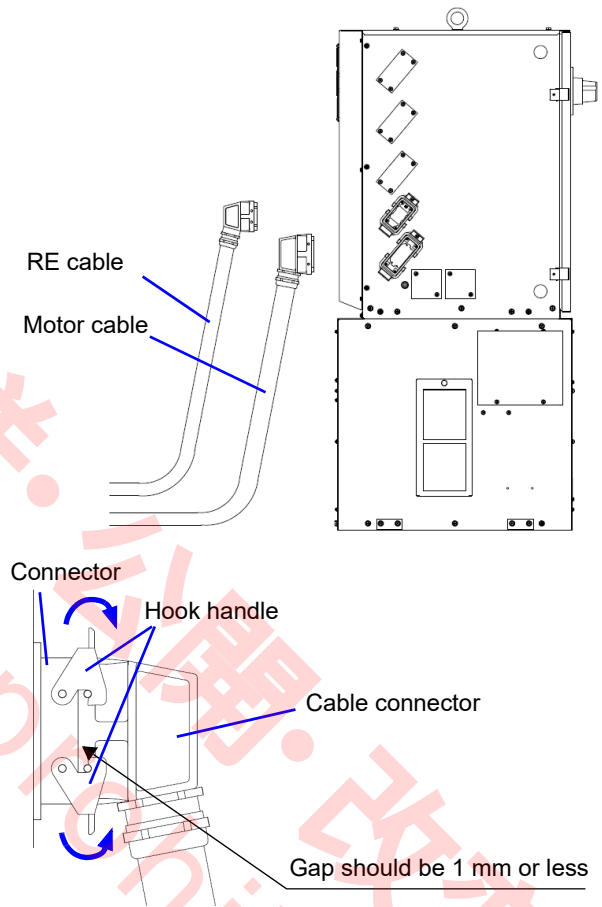

5.1.2 Connecting cables for the built-in welding power source

- (1) Connect the output cable (customer preparation) from welding power source to the output terminal (-) for "BASE METAL" with attached M8 bolt. (Recommended tightening torque: 10.1 N•m-13.4 N•m)
- (2) Connect the welding power cable to the output terminal (+) for "TORCH" with the attached M8 bolt. (Recommended tightening torque: 10.1 N•m-13.4 N•m)
- (3) Connect the base metal voltage detection cable (-) to the voltage detection terminal on the left side of the output terminal (-) for "BASE METAL" terminal.
- (4) Re-install the output terminal cover back in place.

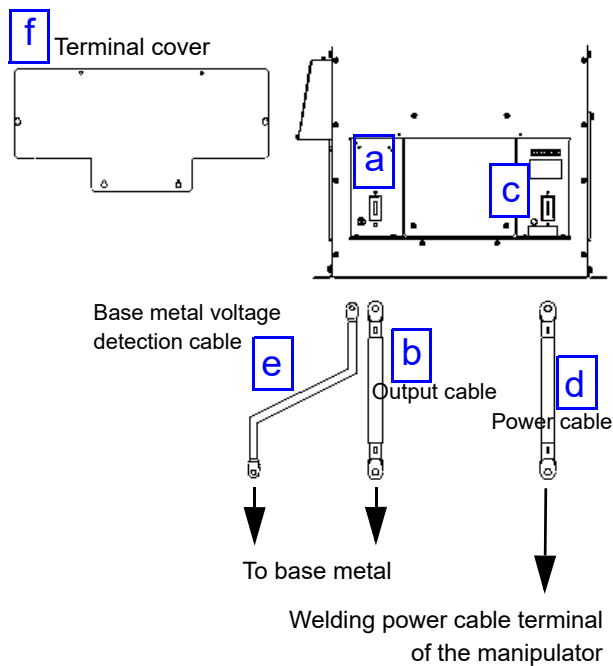

<Connection of output cable/power cable>

No.	Name	Remarks
a	Output (-)	For base metal Bore diameter: 10.5 mm Connect with the provided M8 bolt.
b	Output cable	*Customer preparation article
c	Output (+)	For welding torch Bore diameter: 10.5 mm Connect with the provided M8 bolt.
d	Power cable*1	5 m (standard)
e	Base metal *1 detection cable	10 m Bore diameter: 6 mm
f	Terminal cover	

*1: Provided as incidental equipment.

Note

- After connecting the base metal cable and the power cable, make sure to insulate the connecting part with insulating tape.
- Output cable should be a welding cable or a tough rubber sheathed cable (excluding one with vinyl). The cable length should not be unnecessarily long. Treat the end of the cable with crimp terminal. Use the crimp terminal of the following size.

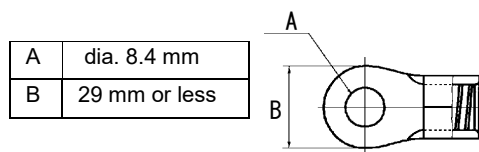

5.1.3 Notes on using multiple robots

To weld one workpiece with multiple robots, observe the following:

- Connect the work cable and voltage detection line of each robot to the closest possible portion to each weld. Be sure the distance between each robot's cable/line connection portions is 500 mm or more. (Weld output of other robots can make the weld unstable)
- Be sure the multiple robots do not share one work cable or voltage detection line.

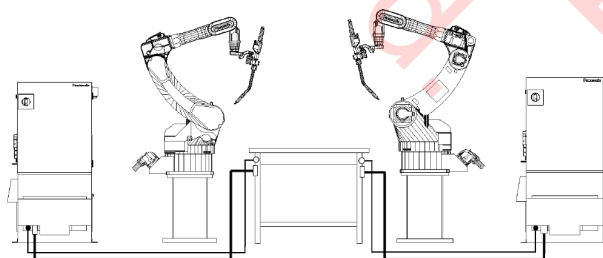

5.2 Connecting teach pendant

Note

Do not bend the TP cable near the connector and connect it to the controller. Otherwise, connecting pins may be damaged.

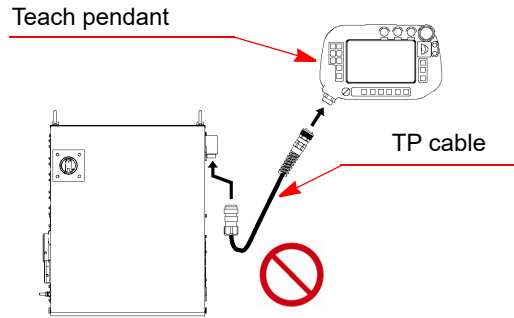

Connect the TP cable to the connector of the teach pendant.

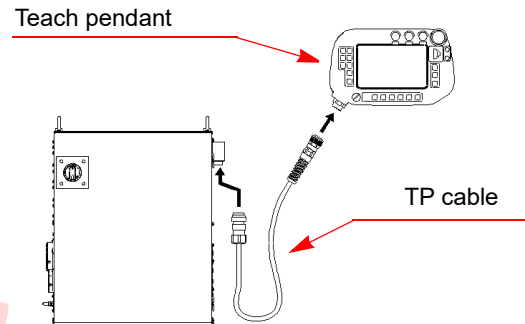

Match the match-marks (concave) at the connector of the TP cable with the match-marks (convex) at the connector of the teach pendant, and then fasten the cable ring.

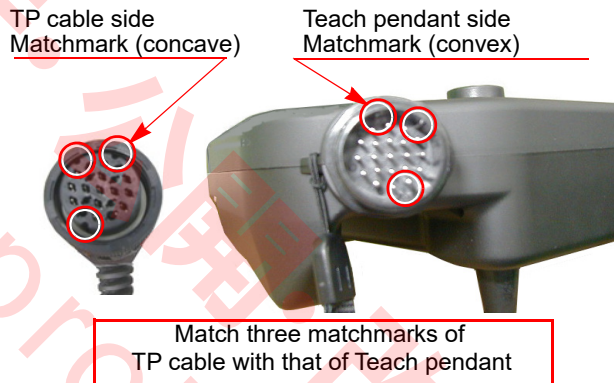

Note

When fastening the cable ring

Do not fasten the ring tight at one time and forcedly. Turn the ring a little and push the cable in and repeat the procedure until the ring is set completely. Fastening the ring forcedly may cause damage or malfunction of the machine.

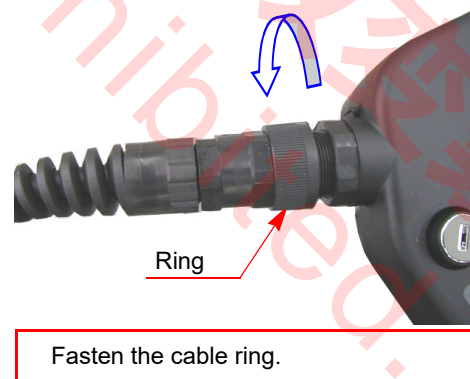

5.3 Connection of ground cable



CAUTION

Provide grounding to the protective earth terminal (PE) of the controller exclusively.
Check the grounding work before operation.

5.3.1 Grounding

Two 14 mm² (AWG6) Green/yellow wires are supplied for grounding.

Note
Size of the protective grounding wires for other devices shall be according to the corresponding instruction.

Countries	Grounding resistance	Size of protective grounding wire
Japan	100 ohm or less	14 mm ² or more.
EU	100 ohm or less	14 mm ² or more.
USA	0.1 ohm or less	AWG6 or more
Others	Conform to all national and local codes	

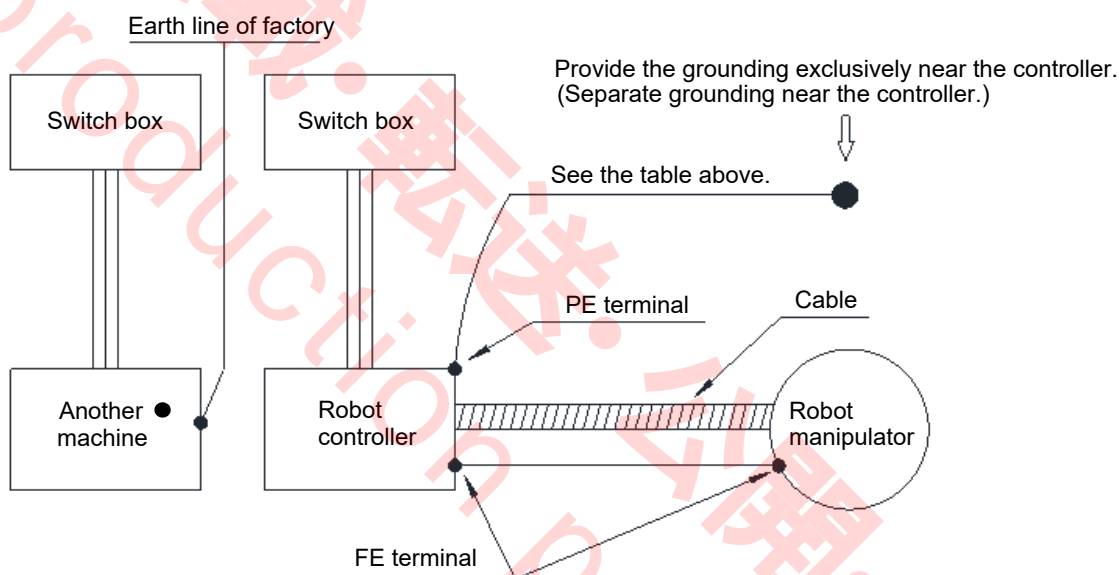

5.3.2 Connection of grounding wire

- (1) Remove the cover of the terminal box (or breaker box).
(Remove four M4 screws for T/Y specs.)
(Remove six M4 screws for E/U specs.)
- (2) Pass the protective grounding wire through the cord lock and then connect it to the PE terminal.
- (3) Put the cover of the terminal box back in place.

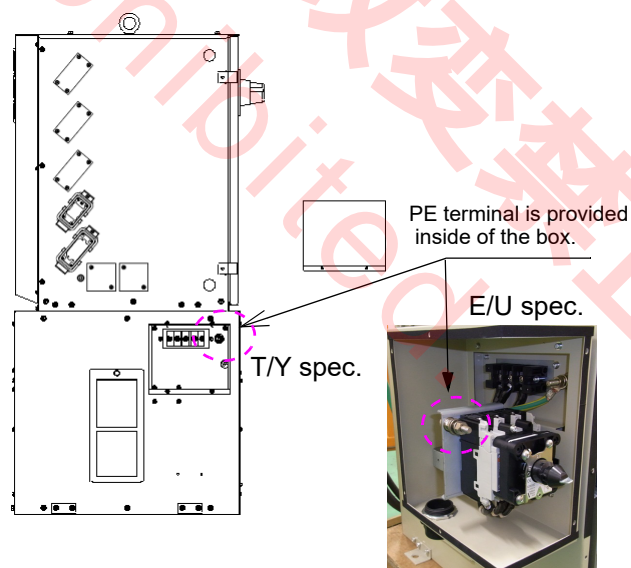

5.4 Connecting primary power source

5.4.1 Wiring primary power cable

Input power capacity	Cable size
22 kVA (20 kW)	14 mm ² or more AWG6 or more

- (1) Be sure to provide no-fuse breaker (earth leakage breaker) or switch with fuse of specified capacity for each controller separately.
- (2) To prevent noise from entering from the power cable, if it is the case, install a filter before the primary input.

Note

- Remarks on "Earth leakage breakers"
Use of earth leakage breakers with medium sensed current and high-speed type, if applied, is recommended to prevent malfunction of the breaker.
- The rated sensed current to prevent malfunction of the earth leakage breaker is about 100 mA in case of using a robot only and 200 mA in case of using an external axis together with a robot. For details and grounding work, please consult your local electrical engineers.
- For E model of LA and TS series manipulators, use the attached noise filter without fail. For details of the noise filter, see the operating instructions of the noise filter.
- Connecting to a power facility other than 200 VAC
(For connection to a power facility of 220 VAC, please refer to section "Using at 220 VAC (For T*/Y* specification)" on page 26)
- You can use either PE or PEN as ground terminal.
- Do not use the terminal "N" of the power facility, if any.
- Please prepare a transformer to convert voltage to 200 VAC at your end.

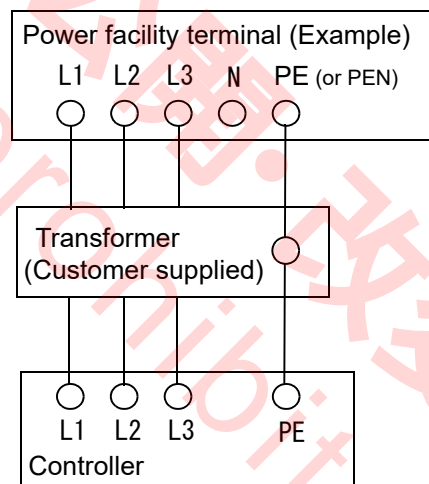
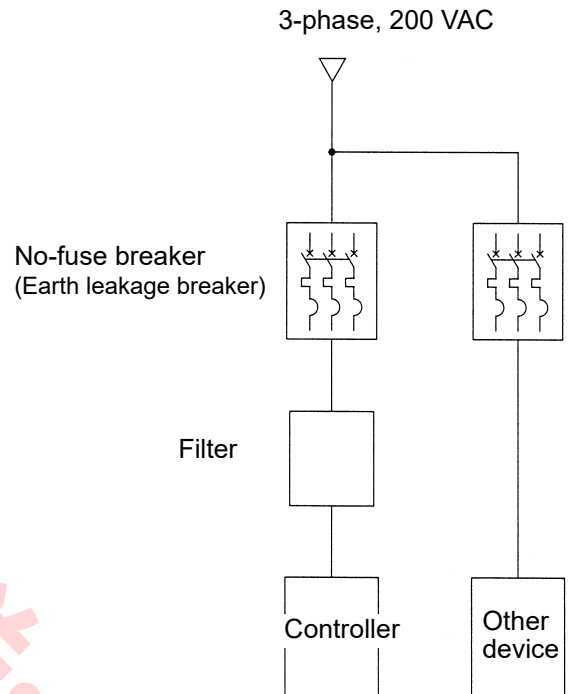

5.4.2 Wiring primary cables (For T*/Y* specification)

- (1) Remove the cover of the terminal box. Pass input cables through the cord lock and then connect it to the input terminals.

Outside diameter of cord lock adaptive cable	ϕ 24 mm-28 mm
--	--------------------

- (2) Put the cover of the terminal box back in place.
- (3) Fix the input cable with a rubber sheet and a saddle.

Note

Connecting screw "A"

- Do not use a wrench
- Tightening torque: 2.5 N•m to 3.0 N•m

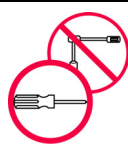

Recommended clamp terminal at "A".
(14 mm² for M6)

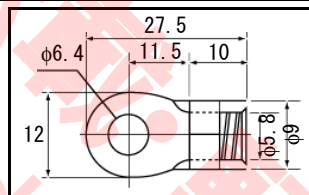

* Input power cable is a customer preparation item.

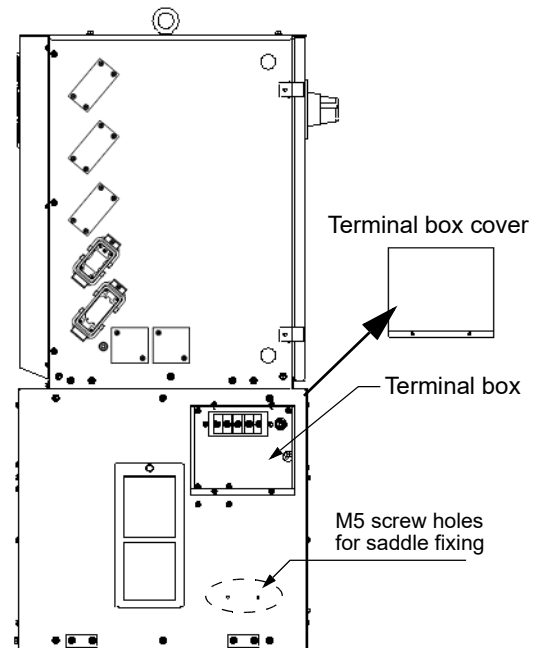

CAUTION

Do not connect a primary power cable of peripheral equipment to the breaker or terminal block inside the controller, or it will cause malfunction or breakdown.

Connection

5.4.3 Wiring primary cables (For E*/U* specification)

* the input power cable is customer preparation.

- (1) Remove the cover of the breaker box. (four M4 screws) Pass input power cables through the cord lock and then connect it to the breaker.

Outside diameter of cord lock adaptive cable	φ 24 mm-28 mm
--	---------------

- (2) Protect the cable coating with the attached rubber sheet and then set the saddle over the rubber sheet to fix the cable.
Wire the input power cable carefully not to touch the edge of the plate. Keep some space between them.
- (3) Put the cover of the breaker box back in place.

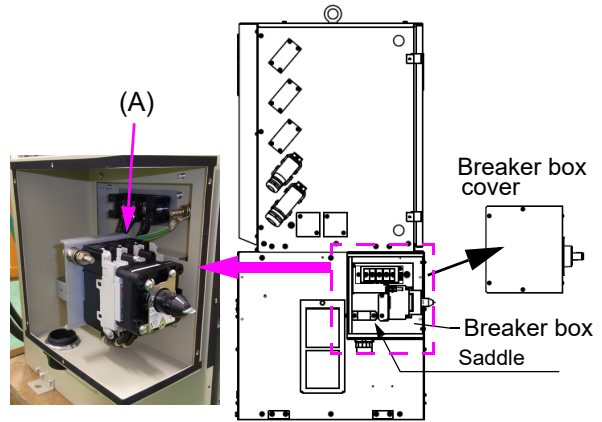

Note	Connecting screw "A"	
	<ul style="list-style-type: none"> • Do not use a wrench • Tightening torque: 5.5 N·m to 7.5 N·m 	

Recommended terminal at "A".
(14 mm² M8)

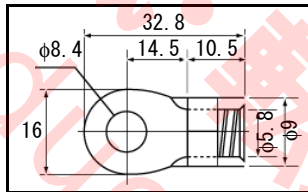

⚠ CAUTION

Do not connect a primary power cable of peripheral equipment to the breaker or terminal block inside the controller, or it will cause malfunction or breakdown.

5.4.4 Using at 220 VAC (For T*/Y* specification)

In case of using the controller at 220 VAC, it is necessary to switch the voltage of the controller and also built-in welding power source.

<How to open the rack>

- (1) Disconnect all four connectors; TPOW, TCOM, CAN0, and CAN1, from the backplane.
- (2) If the controller is WG3 specifications, disconnect three flat cables from the weld control card.

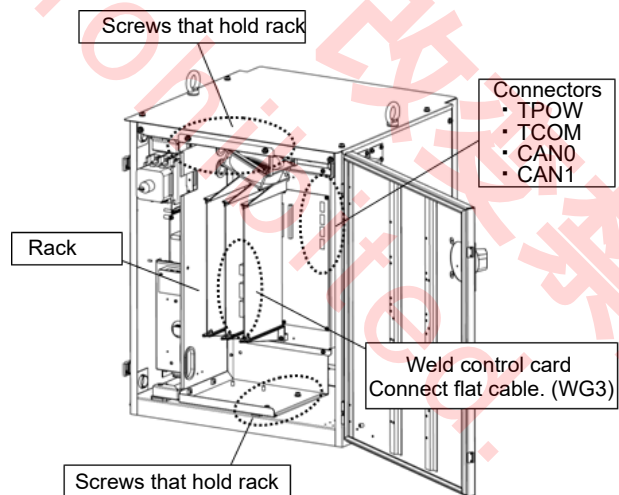

- (3) Loosen the four screws that hold the rack. Then open the rack.

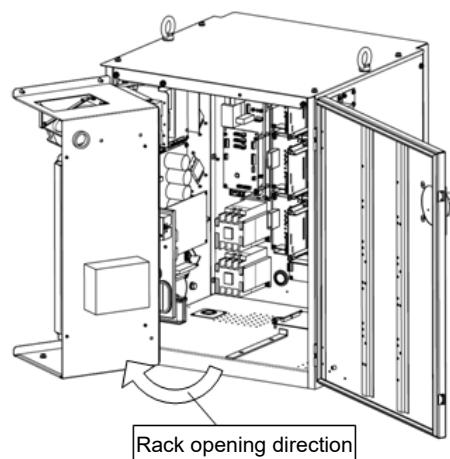

<Controller side>

- (4) Disconnect the primary side harness connector "200 VAC" of the transformer (UTU5315) located at the back of the rack of the controller from the connector "200 VAC" on top of the power card (ZUEP5850). Then connect it to the connector "220 VAC".
- (5) Close the rack in the reverse procedure to opening the rack. Then re-connect all connectors that have been disconnected back in place.
- (6) Connect the power cable.

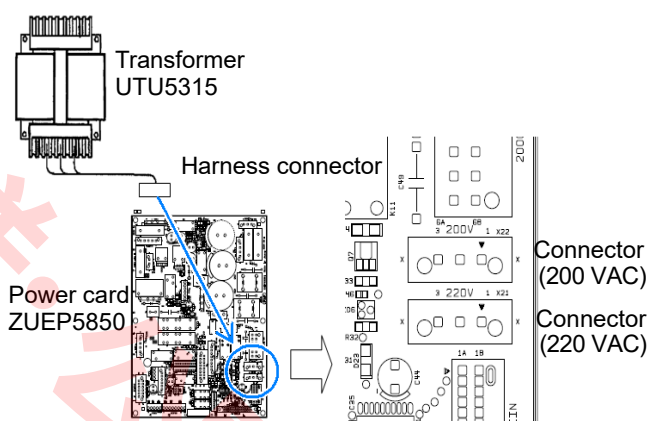

<Built-in welding power source>

Open the panel at the bottom of the left side panel of the controller, and change the harness connections of the built-in welding power source.

- Using at 200 VAC: Connect "VIN" and "200 VAC".
- Using at 220 VAC: Connect "VIN" and "220 VAC".

● Applicable models:

T Spec / Y Spec*

- * Other models are not switchable to 220 VAC input as components of such controllers do not support the use at 220 VAC input.

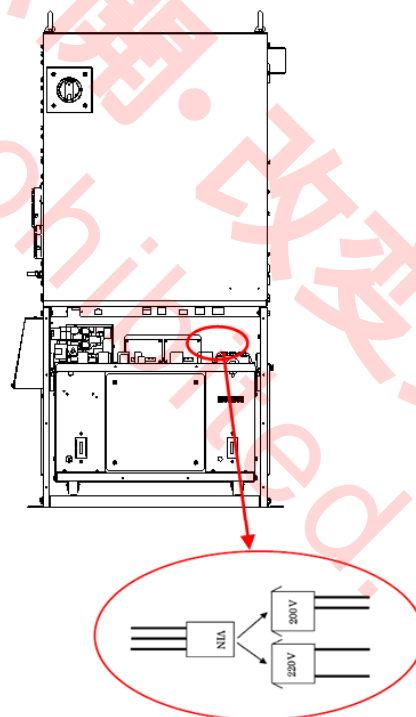

Change harness connection

Connection

5.4.5 Door handle

Normally the door handle is in the ON state during operation. The door handle is used to turn ON/OFF the switch.

Note

- Allow 3 seconds interval after turning off the door handle and before back ON again. If the interval is not long enough, the alarm "Accidental power failure is detected." can occur. In such a case, turn on the power switch anew.
- Please allow 3 to 5 minutes of cooling down of the inside of the built-in welding power source after welding operation before turning power off the door handle.

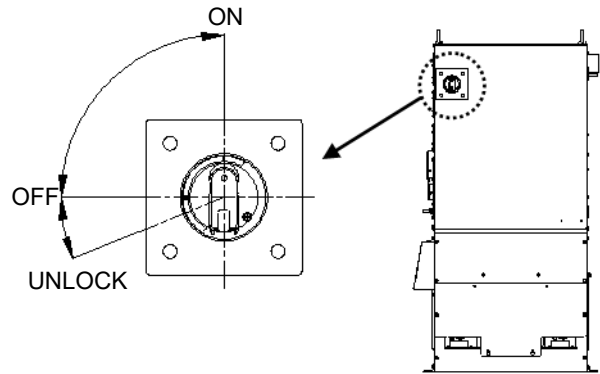

< Operation >

- (1) Turn the handle clockwise to turn ON the switch, and counter-clockwise to turn it OFF. Turn the handle further to the left to UNLOCK the door.
- (2) Set the handle to the OFF position before closing the door.
When the door switch is turned on, power to the controller and power to the built-in welding power source are turned on.

5.4.6 Lock switches with padlock

1) Lock the door handle switch

Use a padlock (customer preparation) to lock the door handle at the OFF position.

- (a) Set the door handle to the OFF position.
- (b) Push the end of the handle, then the hasp for a padlock comes out.
- (c) Put a padlock on the door handle.

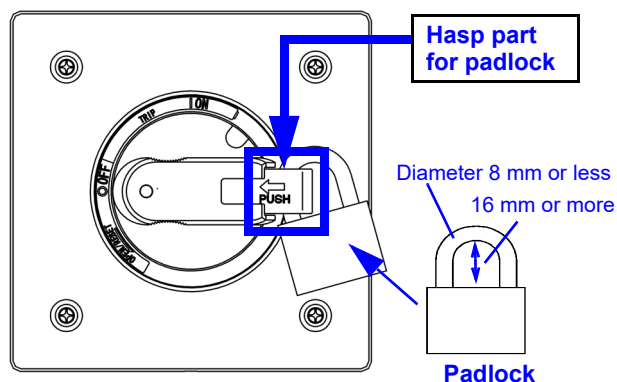

2) Lock the breaker switch inside the controller

Use a padlock (customer preparation) to lock the breaker switch inside the controller at the OFF position. Refer to the following figure to set a padlock.

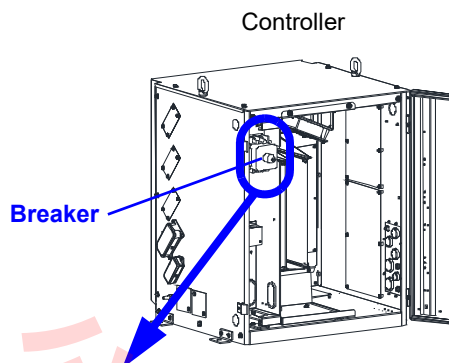

* Shape of the breaker switch varies with the period when the controller was manufactured.

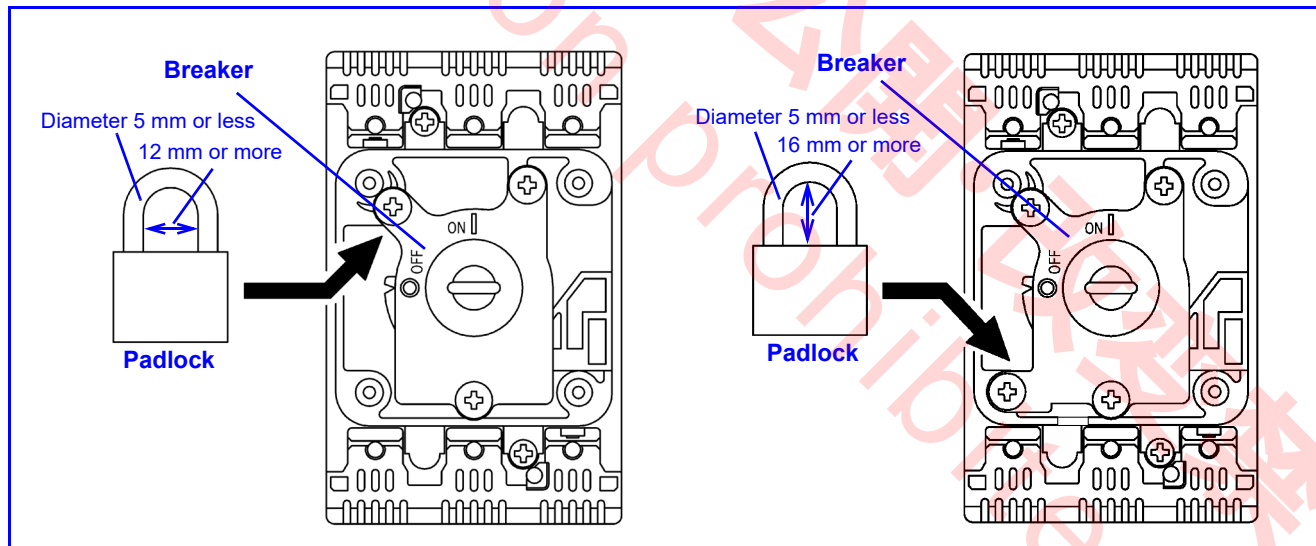

5.5 Connecting and control method of external device

⚠ CAUTION

Observe the following instructions in case of connecting external equipment.

- Apply a radio shield wire as I/O connecting cable between an external device and robot I/O circuit in order to protect the controller from noise.
- Connect the shield wire to the FE terminal (⏏) on the left side of the controller.
- The FE terminal is provided to prevent noise.
- If a system comprises a machine which generates high frequency (such as TIG, plasma), the robot I/O circuit may be damaged by the high frequency noise. Be sure to design so that any external input to the system should use a no-voltage contact signal and any output to an external device should be converted into relay contact output.
- At the time of wiring to the inside of the controller, make sure to apply measures against noise by running the lead-in cables along the side panel or base panel to keep the lead-in cables away from the boards and cables inside the controller.
- If a trouble, such as an error stop, whose probable cause is noise from external equipment occurs, use a noise filter unit. The noise filter unit prevent introduction of external noise into the unit. For details, please refer to section “5.6 Using noise filter unit”.
- Do not connect the ground cable to the COM of the sequencer card. Otherwise, it will cause the controller to malfunction or break down.

- To connect cables from an external device to the robot I/O circuit, draw the cables into the controller through the wiring ports on the IO panel located at the lower right of the right side panel of the controller (see the figure on the right).
- At the time of drawing a cable through the wire port, make sure to fix the cable with a cord lock or the like so as to prevent dust from getting into the controller.
(* Remove the hole plug of the wiring port when drawing a cable.)

As for each of the following connections, please refer to the specified section.

Safety I/O circuit	6. Safety I/O Specifications
External device	7. External Control Signal Connection

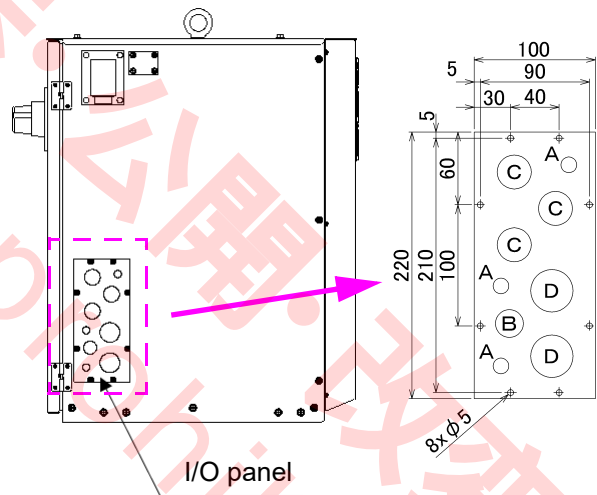

I/O panel hole size (Unit: mm)	
Hole A (3 pcs.)	φ 13
Hole B (1 pcs.)	φ 23
Hole C (3 pcs.)	φ 28
Hole D (2 pcs.)	φ 35

5.6 Using noise filter unit

● Part list

No	Description	Q'ty	Note
1	Clamp filter	1	Accessories
2	Fixing band	1	
3	Fixing plate	1	

● Installation

- (1) Connecting procedure varies with COM the signal wire is connected to. (See the figure on the right.)
 - (a) Disconnect the signal wire from COM (A), wind it around the clamp filter four turns, and then connect it to COM (A).
 - (b) Disconnect the signal wires from COM (A) and COM (B), wind them around the clamp filter four turns, and then connect them to COM (A).
 - (c) Disconnect the signal wire from COM (B), wind it around the clamp filter, and then connect it to COM (A).
- (2) Bind the clamp filter and the fixing plate and fix them on the bottom plate of the controller.

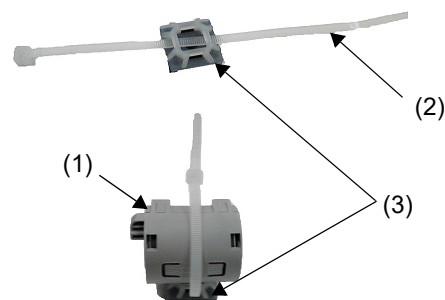

Note

Check the following of the following phenomena occur.
 The detector activates without a collision.
 The servo turns off on its own during the welding operation in program test mode.
 A file closes on its own during the welding operation in program test mode.

- Check if shielded cables are used.
- Check if the clamp filter is attached to the input/output signal cable.
- Disconnect all input/output signal wires and then check if the above phenomena still occur. If the same error occurs, please consult your local Panasonic distributor.

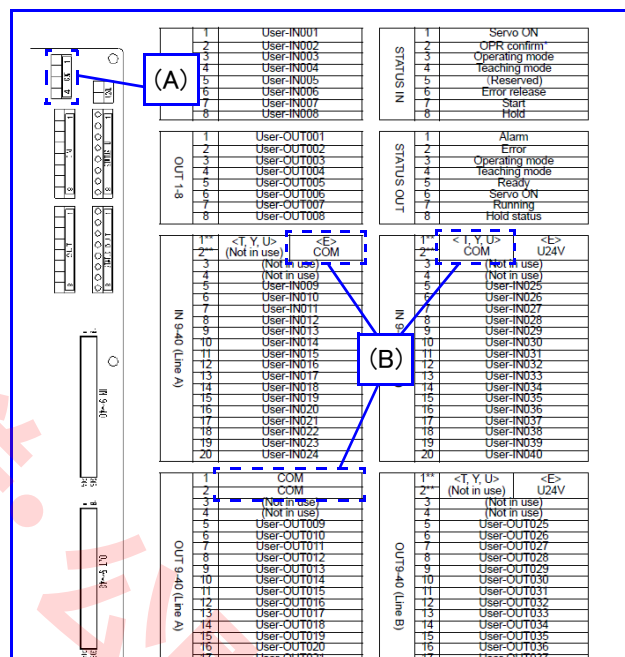

6. Safety I/O Specifications

CAUTION

The product is delivered in emergency stop state. (Open Installation input)
 Confirm total safety of robot system and then short-circuit the external emergency stop input after the completion of the installation and start-up of the system.

CAUTION

About safety circuit

- Apply an independent normally-closed contact and do not connect in parallel.
- In order to avoid malfunction due to contact fusion, apply a contact whose capacity is 5 A or more and the minimum applicable load is 50 mA, 24 VDC.

6.1 I/O for safety circuit

Dual circuit is applied to the safety circuit in order to ensure safety.

Use the safety I/O of the safety card of the controller.
 Please observe the specifications of the safety I/O as follows.

Use components for an external safety device that complies with the standard.

Safety Device	B10d	Compatible standard
Emergency stop switch	100 000	IEC60947-5-1;Annex K IEC60947-5-5
Enable switch	100 000	IEC60947-5-8
Door switch	100 000	IEC60947-5-1;Annex K

Note

Make sure to wire the emergency stop input cable carefully so as to minimize the resistance value of the emergency stop input cable path.

If the resistance of the path becomes 10 Ω or more due to poor connection or other reasons, an emergency stop alarm may go off for no reason or an alarm may not be able to reset.

6.1.1 Spare emergency stop input

An emergency stop input terminal provided as the most significant level of safety circuit. Apply it when an emergency stop input from an external device is so connected that the output of which takes first priority over all other emergency stop push-button switches on the teach pendant.

Use one normally closed 2-contact switch.

- Connect one set of contacts between “SPEMG1+” and “SPEMG1-”, and the other set between “SPEMG2+” and “SPEMG2-”.
- If this input terminal is not to be used, short terminals between “SPEMG1+” and “SPEMG1-”, and also “SPEMG2+” and “SPEMG2-” without fail. (They are factory shorted at shipment.)

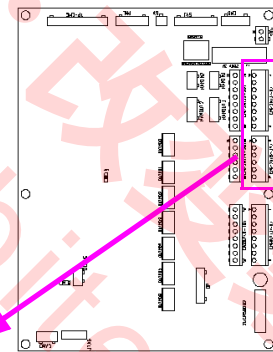

Spare emergency stop input

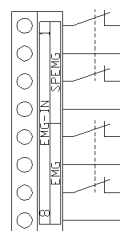

External emergency stop input

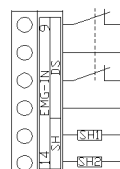

Door stop input

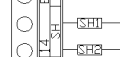

Safety holder input

6.1.2 External emergency stop input

- (1) An input terminal to turn off the servo power of the manipulator from an external device.
- (2) Prepare a switch with two normally closed contacts. Connect one set of contacts between "EXTEMG1+" and "EXTEMG1-", and the other set between "EXTEMG2+" and "EXTEMG2-" of the external emergency stop input.

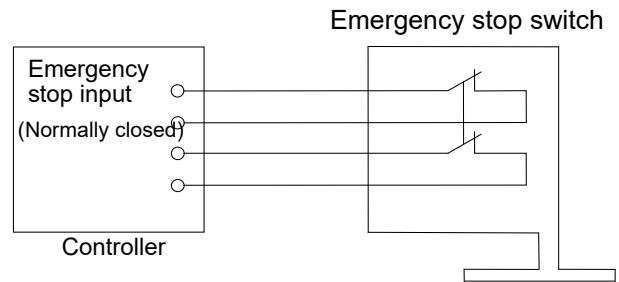

6.1.3 Door stop input

An input terminal to input door status (open/closed) of robot safety fence.

Use a switch with two normally closed contacts.

The robot goes into an emergency stop state when the switch is switched to "OPEN" and the door stop input is input.

Note

- Please note that the door stop input does not function in "TEACH" mode.
- It is factory set to "OPEN" at shipment. With that setting, it is possible to connect interlock of the safety fence and use it.

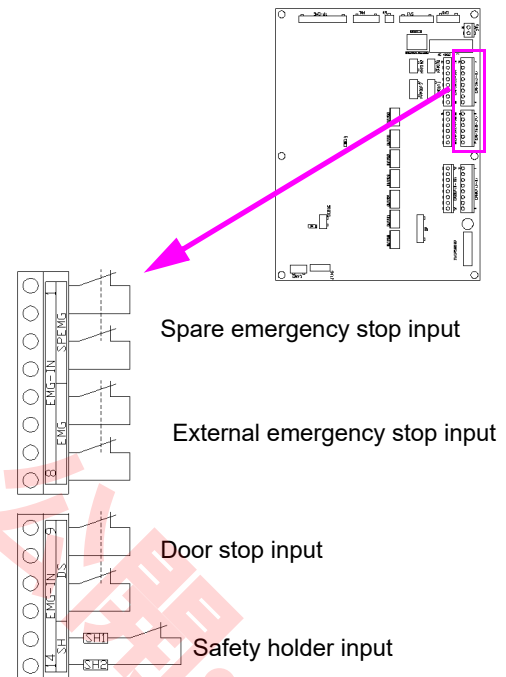

6.1.4 Protective stop 1 input

If the terminal is opened, driving force for all robot axes is stopped in terms of hardware, which stops all operation parts at once.

If the terminal is short-circuited, the safety circuit goes into the ready-to-operate state in terms of hardware.

As for other emergency stops, even if the terminal is short-circuited, the safety circuit remains functioning in terms of hardware unless servo is turned on. This is what make this terminal different from other emergency stops.

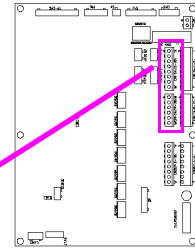

Protective stop1 input

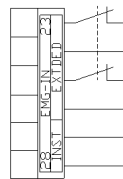

Protective stop2 input

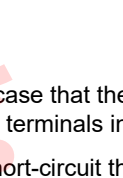

External enabling input

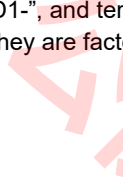

Installation input

6.1.5 Protective stop 2 input

Movements are almost the same as that of Protective Stop 1. This terminal is used to receive the emergency stop output from its cooperative counterpart in multi-cooperative robot control.

6.1.6 External enabling input

- An input terminal used to make the enabling function effective from an external input.
- Servo power is turned ON when both the enabling switch on the teach pendant and the external enabling input are ON. Uses one normally open 2-contact switch.

- In case that the external enabling input is not used, set the terminals in the following state:

Short-circuit the terminals "EXTDED1+" and "EXTDED1-", and terminals "EXTDED 2+" and "EXTDED 2-". (They are factory shorted at shipment.)

6.1.7 Input of the safety circuit

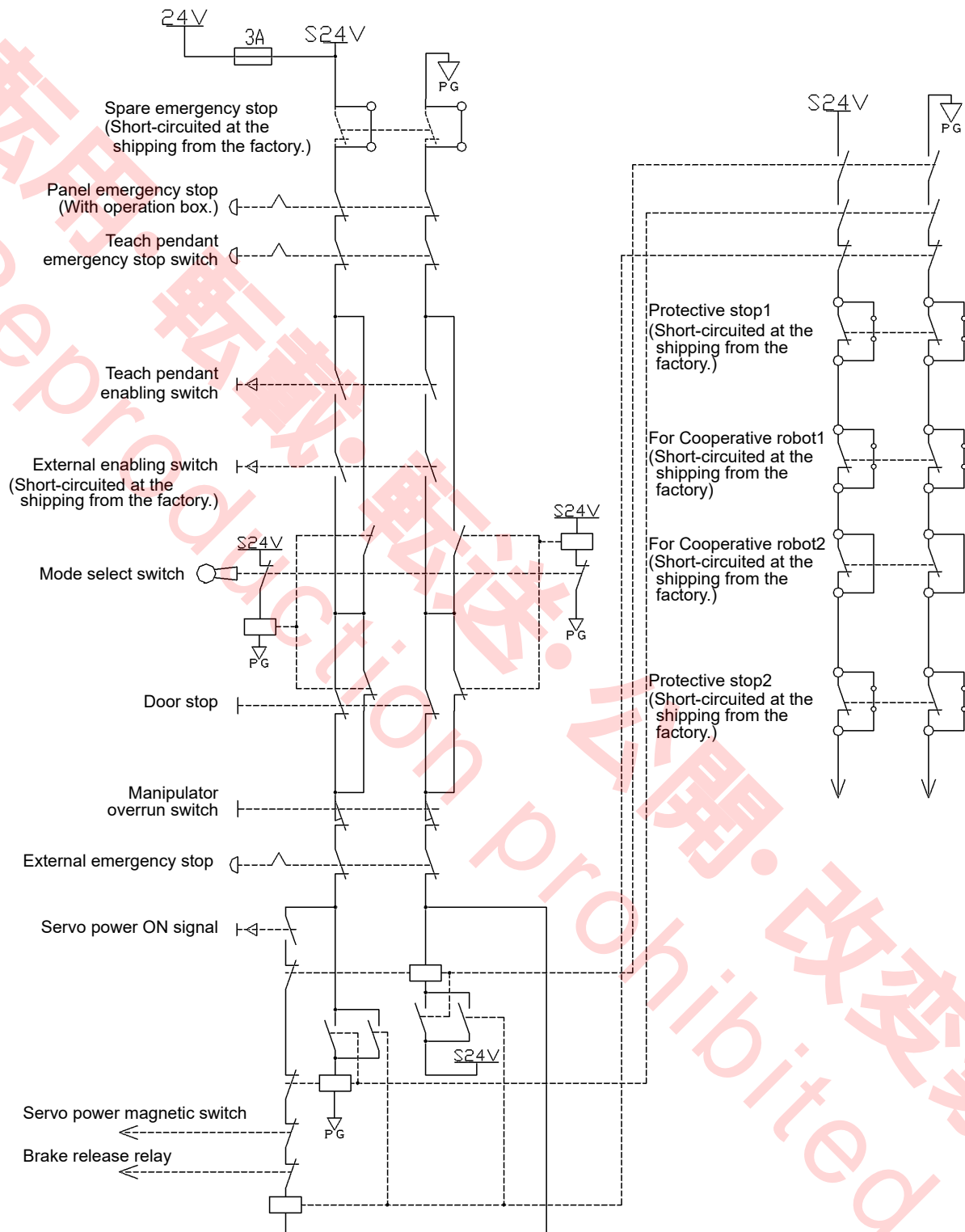

- The controller with built-in welding power source is also equipped with the safety circuit. In case of an emergency stop, the safety circuit turns off the primary power of the welding power source. As it also turns off power to the wire feeder, the wire feeder becomes disabled at an emergency stop state.

6.1.8 Emergency stop output

An output terminal to output the emergency stop state.
 (No-voltage relay contact output, Contact ratings: 5 A, 30 VDC, minimum load 100 mA 5 VDC) Open the terminals in an emergency state.

There are four kinds of emergency stop outputs as follows

1	Emergency stop output	How connectors "OUTMD0" to "OUTMD6" of the Safety card are shorted determines its output conditions.
2	Reserved emergency stop output	
3	Emergency stop output for application	How connectors "OUTMD0" to "OUTMD6" of the Safety card are shorted does NOT change its output conditions.
4	Reserved emergency stop output for application	

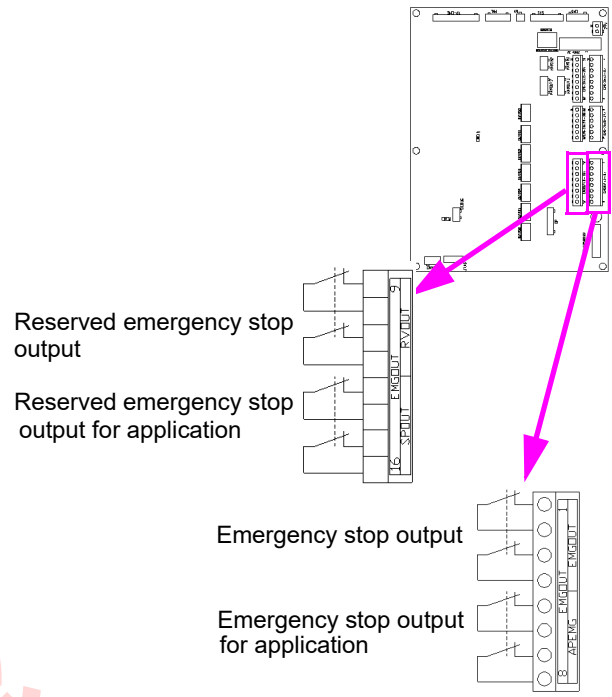

◆ Short connectors and emergency stop

The following show the relationships between emergency stop input type and emergency stop output when each connector is shorted.

Note

OUTMD3 is factory short-circuited at shipment.

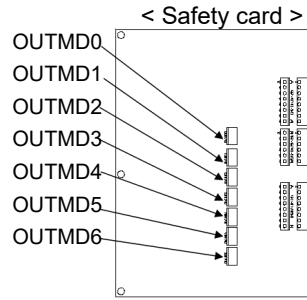

Emergency stop output		"Emergency stop output" and "Reserved emergency stop output"							"Emergency stop output for application" and "Reserved emergency stop output for application"
		OUTMD0	OUTMD1	OUTMD2	OUTMD3	OUTMD4	OUTMD5	OUTMD6	
Shorted connector		OUTMD0	OUTMD1	OUTMD2	OUTMD3	OUTMD4	OUTMD5	OUTMD6	Not related
(1)	Spare emergency stop input	C	C	C	A	A	A	A	A
(2)	Panel emergency stop input (*1)	C	C	C	A	A	A	B	A
(3)	Teach pendant emergency stop input	C	C	C	A	A	A	B	A
(4)	Teach pendant Enabling switch (*2)	C	C	C	A	A	B	B	A
(5)	External enabling input (*2)	C	C	C	A	A	B	B	A
(6)	Door stop input (*3)	C	C	C	A	A	B	B	A
(7)	Overrun input	C	C	C	A	A	B	B	A
(8)	External emergency stop input	C	C	C	A	B	B	B	A
(9)	Protective stop 1 input	E	E	E	B	B	B	B	B
(10)	Emergency stop of its cooperative counterparts in multi-cooperative robot control.	E	E	B	B	B	B	B	B
(11)	Protective stop 2 input	E	B	B	B	B	B	B	B
(12)	In alarm condition	D	D	D	D	D	D	D	D

(*1) It is available only if an operation box (optional) is connected.

(*2) As for enabling switch, the input is valid only when the mode select switch is in TEACH position.

(*3) As for Door stop switch, the input is valid only when the mode select switch is in AUTO position.

A	The emergency stop output terminal goes open when the emergency stop input is input. The emergency stop output terminal is closed when the emergency stop input is released. (In case the mode select switch is in TEACH mode, the emergency stop output terminal stays open state when the enabling switch input is turned on.)
B	The emergency stop output terminal stays closed regardless of the state of the emergency stop input.
C	The emergency stop output terminal goes open when the emergency stop input is input. The emergency stop output terminal is closed when the emergency stop input is released and the servo power is turned on.
D	Input to open the emergency stop output terminal. It remains in open state until the power at the controller is turned off.
E	When the main power is turned on, the emergency stop output terminal goes into the output status of "C". Then, when the servo power is turned on, the output terminal goes into the output status of "A". If one of the following (1) to (8) inputs is turned on, the output terminal goes back into the output status of "C". Subsequently, if the servo power is turned on, the output terminal goes into the output status of "A".

6.2 Other safety input/output

Ensure a safe work environment by using the safety I/O equipped with the safety card.

6.2.1 Safety holder input

Input terminals for safety holder cable, which is not included in the safety circuit. The input is always monitored by software. They (SH terminals) are factory connected to the safety holder cable as shipment as follows.

Note

Safety holder inputs are factory connected to the user connector of the manipulator.

* “SH+” and “SH-” do not have polarity.

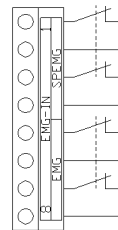
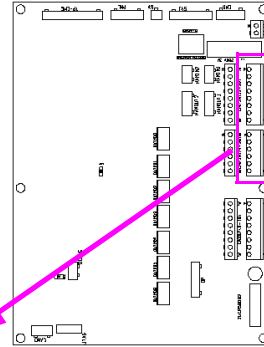

Spare emergency stop input

External emergency stop input

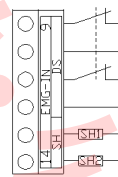

Door stop input

Safety holder input

6.2.2 Installation input

Set the input open to indicate the warning message “Now installing. Check wire connections. Short INST.” on the screen of the teach pendant every time the controller is turned ON and mode change (operation mode/teaching mode) is executed so as to warn the operator of the robot system that the safety I/O setting of the robot system has not competed.

Note

Short this input after the completion of the installation and start-up of the system or in normal operation.

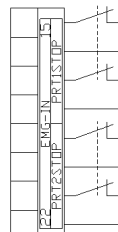
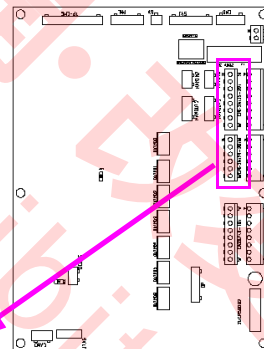

Protective stop1 input

Protective stop1 input

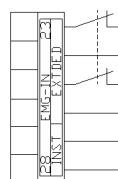

External enabling input

Installation input

7. External Control Signal Connection

7.1 Terminal location of the sequencer card

Specifications	Part number	Output type
T / Y / U	ZUEP5789	Open collector (NPN)
E	ZUEP5826	Open collector (PNP)

Note

- Allocation of User I/O terminals vary with start method.
- Terminals marked with
 - *: An additional setting is needed to enable the signal.
 - ** : Functions vary with the circuit board (see left table).

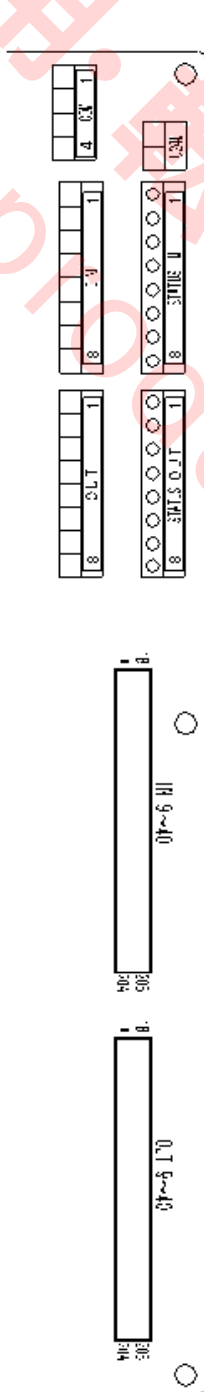

Terminal	Function
1	User-IN001
2	User-IN002
3	User-IN003
4	User-IN004
5	User-IN005
6	User-IN006
7	User-IN007
8	User-IN008

Terminal	Function
1	Servo ON
2	OPR confirm*
3	Operating mode
4	Teaching mode
5	(Reserved)
6	Error release
7	Start
8	Hold

Terminal	Function
1	User-OUT001
2	User-OUT002
3	User-OUT003
4	User-OUT004
5	User-OUT005
6	User-OUT006
7	User-OUT007
8	User-OUT008

Terminal	Function
1	Alarm
2	Error
3	Operating mode
4	Teaching mode
5	Ready
6	Servo ON
7	Running
8	Hold status

Terminal	<T, Y, U> (Not in use)	<E> COM
1**		
2**		
3	(Not in use)	
4	(Not in use)	
5	User-IN009	
6	User-IN010	
7	User-IN011	
8	User-IN012	
9	User-IN013	
10	User-IN014	
11	User-IN015	
12	User-IN016	
13	User-IN017	
14	User-IN018	
15	User-IN019	
16	User-IN020	
17	User-IN021	
18	User-IN022	
19	User-IN023	
20	User-IN024	

Terminal	<T, Y, U> COM	<E> U24V
1**		
2**		
3	(Not in use)	
4	(Not in use)	
5	User-IN025	
6	User-IN026	
7	User-IN027	
8	User-IN028	
9	User-IN029	
10	User-IN030	
11	User-IN031	
12	User-IN032	
13	User-IN033	
14	User-IN034	
15	User-IN035	
16	User-IN036	
17	User-IN037	
18	User-IN038	
19	User-IN039	
20	User-IN040	

Terminal	Function
1	COM
2	COM
3	(Not in use)
4	(Not in use)
5	User-OUT009
6	User-OUT010
7	User-OUT011
8	User-OUT012
9	User-OUT013
10	User-OUT014
11	User-OUT015
12	User-OUT016
13	User-OUT017
14	User-OUT018
15	User-OUT019
16	User-OUT020
17	User-OUT021
18	User-OUT022
19	User-OUT023
20	User-OUT024

Terminal	<T, Y, U> (Not in use)	<E> U24V
1**		
2**		
3	(Not in use)	
4	(Not in use)	
5	User-OUT025	
6	User-OUT026	
7	User-OUT027	
8	User-OUT028	
9	User-OUT029	
10	User-OUT030	
11	User-OUT031	
12	User-OUT032	
13	User-OUT033	
14	User-OUT034	
15	User-OUT035	
16	User-OUT036	
17	User-OUT037	
18	User-OUT038	
19	User-OUT039	
20	User-OUT040	

External Control Signal Connection

● Sequencer card

Terminal or connector	Application	
COM	Common.	
U24V	(T/Y/U spec.)	Maintenance use.
	(E spec.)	24 VDC input for I/O

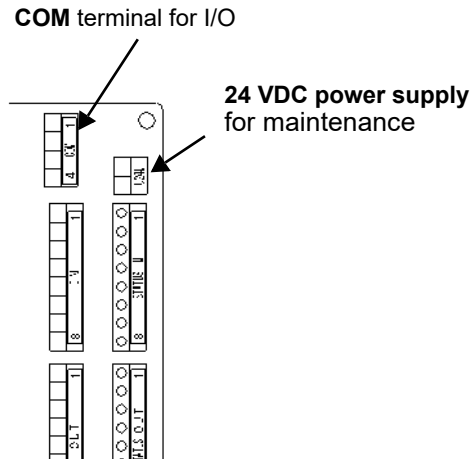

7.2 Serial interface

The backplane card is provided with serial connectors to connect optional units and/or welding power source.

Connector	Application
RS-232C RS-422	For an optional units or digital communication of welding power source.
EX_IO	For an optional unit.

Refer to the following correspondence table of port numbers and connectors.

Connector	Port number	Connector symbol
RS-232C	Port 1	232C-1(X20)
	Port 2	232C-2(X17)
	Port 3	232C-3(X16)
RS-422	Port 1	422-1(X19)
	Port 2	422-2(X18)
	Port 3	422-3(X12)
	Port 4	422-4(X11)
	Port 5	422-5(X9)

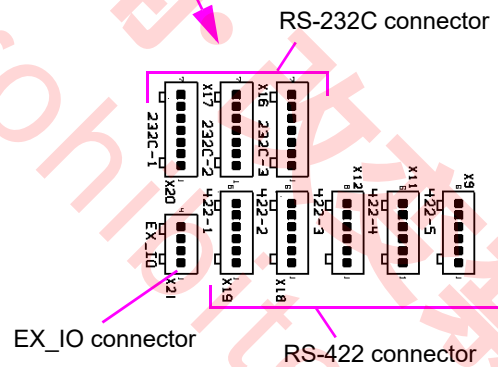
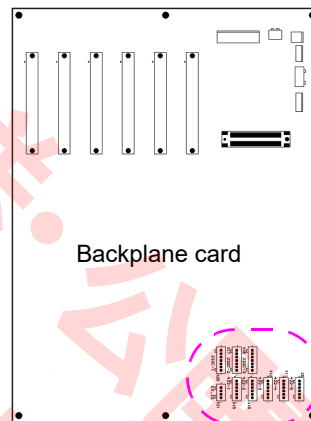

7.3 I/O terminal equivalent circuit

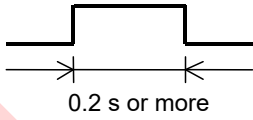
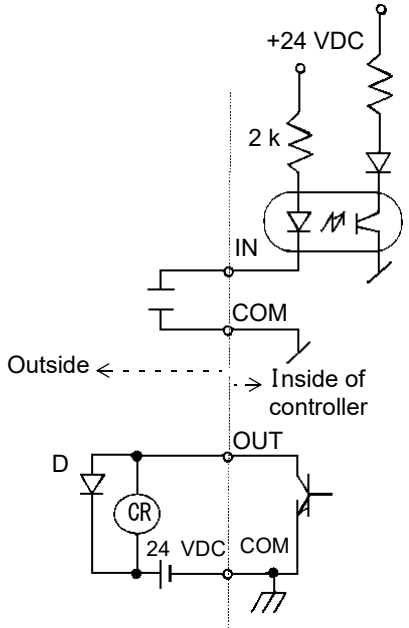
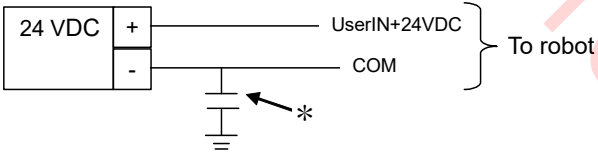
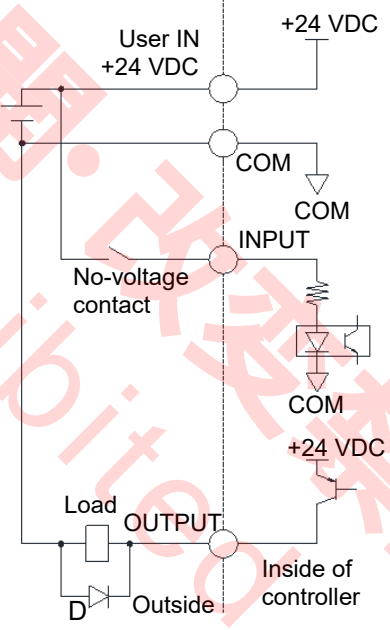
Spec.		
<p>T Y U</p>	<ul style="list-style-type: none"> ● Input terminal equivalent circuit <ul style="list-style-type: none"> To receive no-voltage ON/OFF contact signal from an external equipment. External relay contact to be connected... 1 ohm or less, Chattering10 ms or less Pulse amplitude of an input signal should be 0.2 s or more.  <ul style="list-style-type: none"> ● Output terminal equivalent circuit <ul style="list-style-type: none"> Open collector (NPN) output. Rated output is 24 VDC, 75 mA. Use a relay whose coil voltage is 24 VDC and coil current is 75 mA DC or less, and attach a noise adsorbing diode: D (100 VDC, 1 A). Rated load of the emergency stop output: 5 A, 30 VDC. 	
<p>E</p>	<ul style="list-style-type: none"> ● Power to activate input/output <ul style="list-style-type: none"> It is necessary to apply 24 VDC of supply voltage between 24 VDC input and COM. Turn ON/OFF the power synchronous to the control power of the controller. The power to be provided by customer: <ul style="list-style-type: none"> • Voltage: 24 VDC +10 %/-0 % • Capacity: 75 W or more Apply noiseless stable power is applied. <p>To remove the common-mode noise, refer to the following figure and input the capacitor.</p> <p>* Recommended capacitor: Film capacitor 0.1 μF, 50 VDC.</p>  <p>To the ground of the base panel of the robot controller</p> <ul style="list-style-type: none"> ● Input terminal equivalent circuit: <ul style="list-style-type: none"> To receive no-voltage ON/OFF contact signal from an external equipment. External relay contact to be connected 1 ohm or less Chattering 10 ms or less Pulse amplitude of an input signal should be 0.2 s or more. ● Output terminal equivalent circuit <ul style="list-style-type: none"> Open collector (PNP) output. Rated output is 24 VDC, 75 mA Use a relay whose coil voltage is 24 VDC and coil current is 75 mA DC or less, and attach a noise adsorbing diode: D (100 VDC, 1 A). Rated load of the emergency stop output: 5 A, 30 VDC. 	

External Control Signal Connection

7.4 Auto start settings

For details of settings and usage of the auto start, please refer to the operating instructions (Teach pendant for arc welding industrial robots.)

7.5 Status IN/OUT

Dedicated input/output terminals to send signals when the robot is in specified state or to change robot status according to the signal received.

7.5.1 Status INPUT

- Dedicated input terminals

Status INPUT	Description
External servo ON input	<p>Turn ON to enable servo power ON if the following conditions are all satisfied.</p> <p><u>Condition 1:</u> Status output signal 'Ready' output signal is ON.</p> <p><u>Condition 2:</u> Mode select switch is set to operation mode ('AUTO' position) and not in Mode error state.</p> <p><u>Condition 3:</u> Mode select is set to auto-operation (in operation mode)</p> <p><u>Condition 4:</u> Mode select switch is not switched to 'TEACH' position due to override in operation.</p> <p><u>Condition 5:</u> The 'Emergency stop' input is not ON.</p> <p>The input signal must satisfy the following conditions.</p> <p>The input signal must be ON in 0.2 second after the 'Ready' output signal goes ON.</p> <p>The input signal must be kept ON for 0.2 second or more.</p> <p>If you try to turn on servo within 1.5 seconds after turning it off, "Retry to turn on servo" is displayed and servo doesn't turn on .</p>
Error release input	<p>When the robot is in an error state and the error dialog box is displayed, turn ON this input to close the dialog box. At that time, the error output goes off if it is in ON state. Input signal is effective when the signal state is switched and kept for 0.2 second or more.</p>
Start input	<p>Turn ON this input signal to run a program. In a hold state, turn on to restart. The input signal is ignored under the following conditions.</p> <ul style="list-style-type: none"> • The servo power is OFF. • Auto-operation is not set. • In error condition. • Stop input is ON. • In override state.
Stop input	<ul style="list-style-type: none"> • Turn ON this input signal to bring the operating robot into a hold state. • While the signal is ON, re-start, manual operation and trace operation are not operable. • The robot remains in a hold state even if this signal is turned OFF. • To restart operation, turn ON the start input signal.
Operating mode input	<ul style="list-style-type: none"> • It is to switch the mode from teaching mode to operation mode. • Use this input when the robot is in teaching mode and operation mode is desired. • When the input signal is turned ON, a message to switch the mode select switch to operation mode appears. • Switch the mode select switch to 'AUTO' or turn OFF the operating mode input to close the message box. <p>Please be advised that while the message box is displayed, the robot is in the error state.</p>
Teaching mode input	<ul style="list-style-type: none"> • It is to switch the mode from operation mode to teaching mode. • Use this input when the robot is in operation mode and teaching mode is desired. • When the input signal is turned ON, a message to switch the mode select switch to teaching mode appears. • Switch the mode select switch to 'TEACH' or turn OFF the teaching mode input to close the message box. <p>Please be advised that while the message box is displayed, the robot is in the error state.</p>
OPR confirm input	<p>In case of using the operation box, turn ON this input signal to release the interlock occurred at the time of switching to AUTO mode. (You can also use the AUTO mode switch on the operation box to release the interlock.)</p> <p>< Note ></p> <ul style="list-style-type: none"> • The interlock at the time of switching to AUTO mode occurs if the controller is equipped with the operation box either as standard (for UL or CE specification) or as optional. • It is necessary to complete the management settings for the operation box to enable this input. Please refer to the operating instructions (Operation) for details.

7.5.2 Status OUTPUT

Status OUTPUT	Description
Alarm output	<ul style="list-style-type: none"> The signal is output when the robot goes into an alarm condition. (At that time servo power is turned OFF) Unless power is turned OFF, the output signal remains in ON state.
Error output	<ul style="list-style-type: none"> The signal is output while the robot is in an error condition. The signal is turned OFF when the error is released.
Operating mode output	<ul style="list-style-type: none"> The signal is output in operation mode (including override.) While the message box to switch to teaching mode is displayed (by turning on the 'Teaching mode' input), if the operation mode is selected, this signal remains ON.
Teaching mode output	<ul style="list-style-type: none"> The signal is output in teaching mode (excluding override.) While the message box to switch to operation mode is displayed (by turning on the 'Operating mode' input), if the teaching mode is selected, this signal remains ON.
Ready output	<ul style="list-style-type: none"> The signal is output when the robot is ready to receive a status input signal. It goes OFF when the robot is in an alarm condition or when the 'Emergency stop' input is ON.
Servo ON output	<ul style="list-style-type: none"> The signal is output when the servo power is ON. <p><Examples of installing a signal light></p> <div style="display: flex; justify-content: space-around;"> <div style="border: 1px solid black; padding: 5px; width: 45%;"> <p>T / Y / U spec. Connection to the Open collector (NPN) circuit</p> </div> <div style="border: 1px solid black; padding: 5px; width: 45%;"> <p>E spec. Connection to the Open collector (PNP) circuit</p> </div> </div>
Running output	<ul style="list-style-type: none"> The signal is output while running a program (including override.) It is turned OFF when the robot goes in hold or emergency stop state, and turned ON again when the robot is re-started.
Hold status output	<ul style="list-style-type: none"> The signal is output when the running program is stopped in operation mode. The signal is output while the robot is in a hold state due to an error or emergency stop input, and is turned OFF when re-started. The signal is turned OFF when the mode select switch is placed in 'TEACH' position. When the mode select switch is placed in operation mode and the robot is ready to restart after turning on servo power, the signal is turned ON.

7.5.3 Status I/O to be allocated to user terminals

For details of setting procedure and functions of status I/Os allocated to the user terminals, please refer to the operating instructions (Teach pendant for arc welding industrial robots.)

7.6 Flowchart of Status Outputs

7.6.1 Operating and Holding output

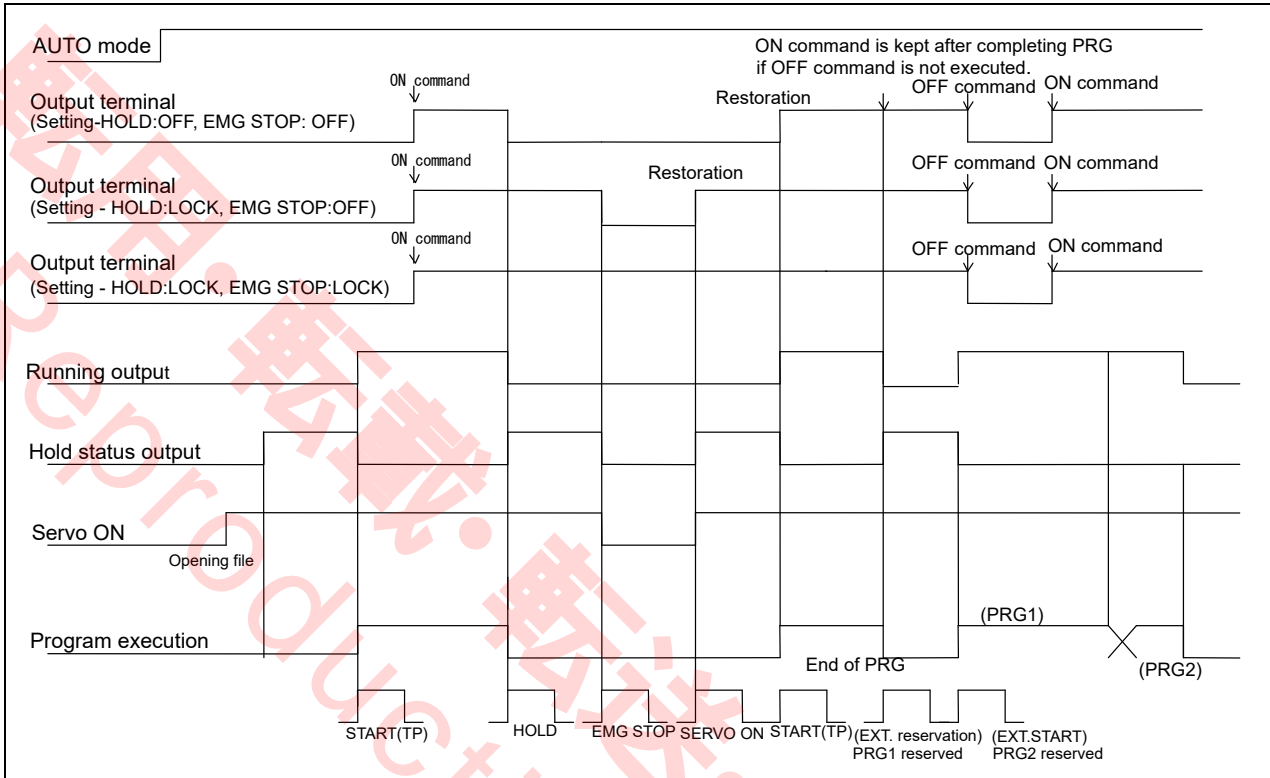

Note

The chart is drawn as positive logical setting case.

7.6.2 Mode change (I/O monitor)

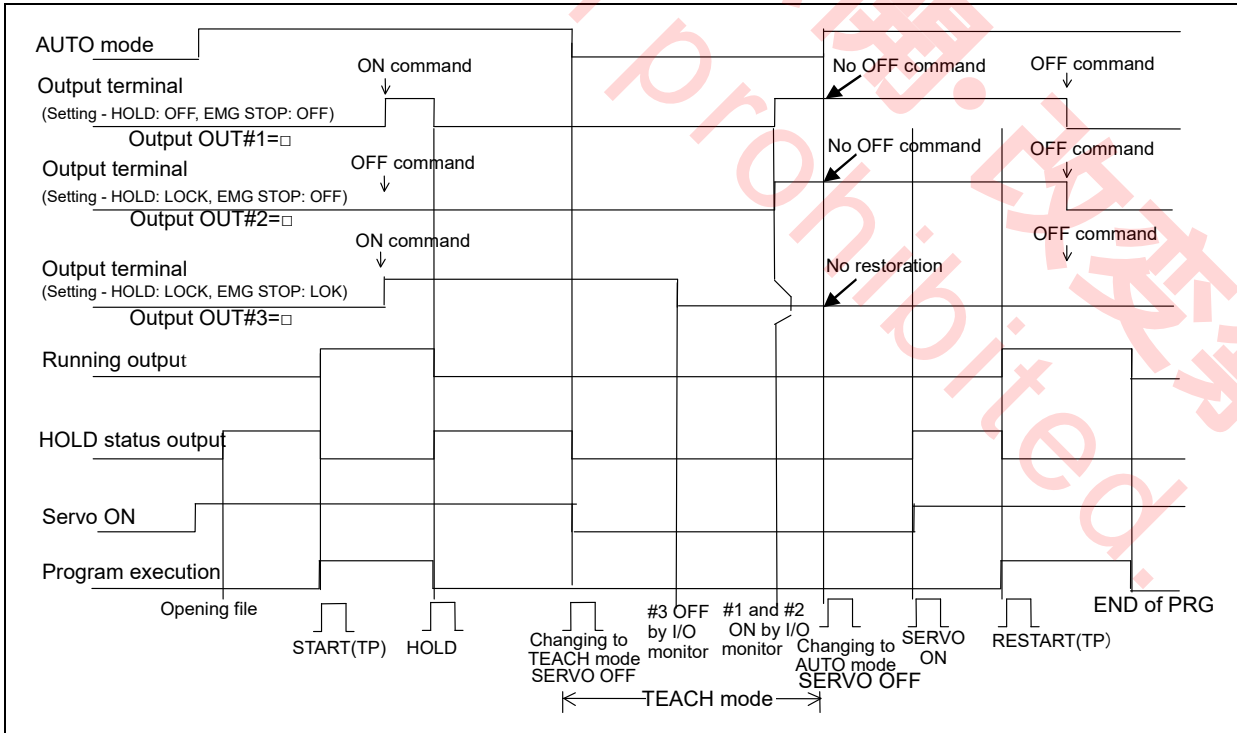

Note

The chart is drawn as positive logical setting case.

7.6.3 Emergency stop 1

The following chart shows output terminal status to the emergency stop operation when it is set to the safety PCB connector OUTMB1.

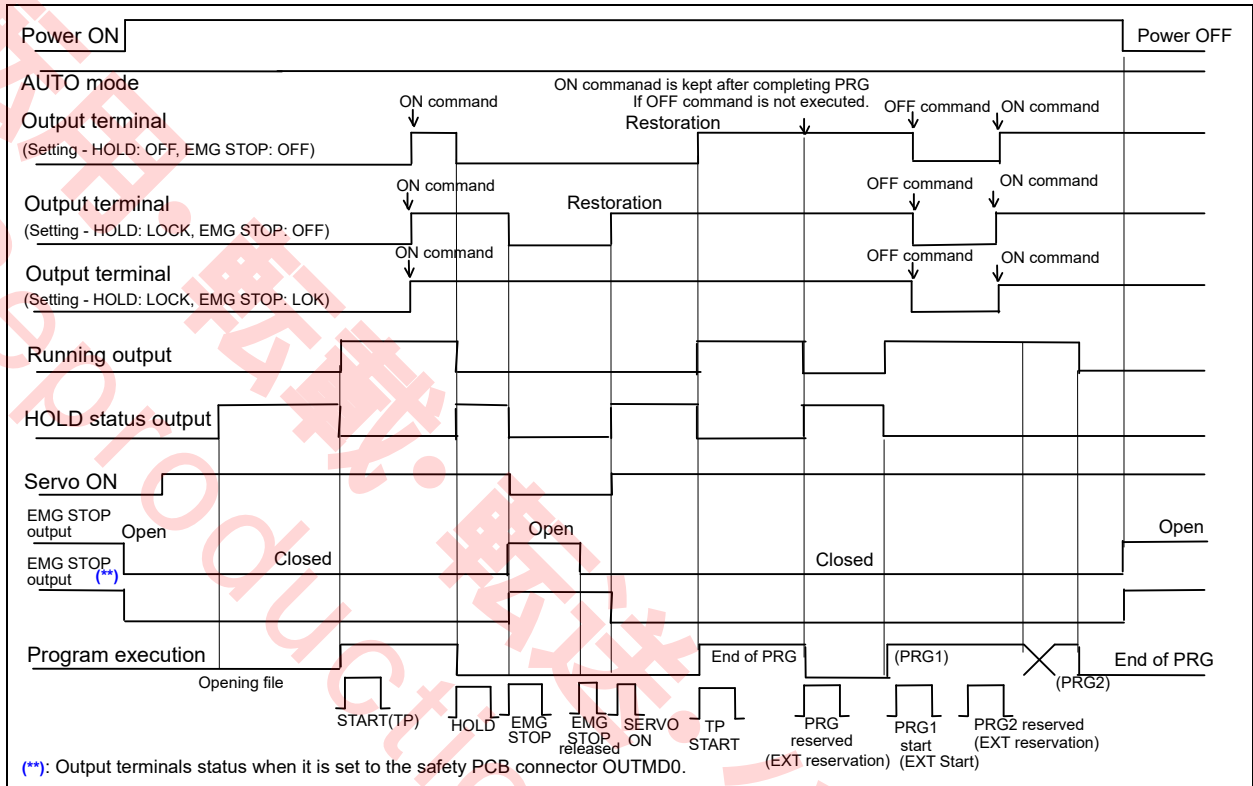

Note

The chart is drawn as positive logical setting case.

7.6.4 Emergency stop 2

Status outputs of “Emergency stop output” and “Emergency stop status output” vary with mode setting.

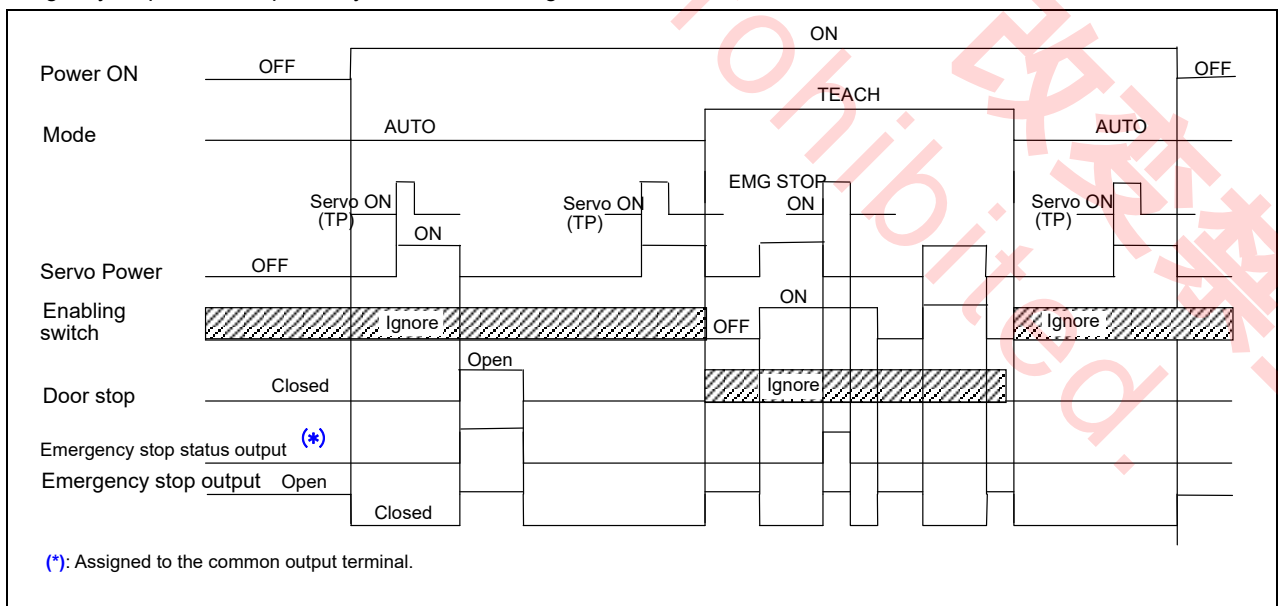

Note

The chart is drawn as positive logical setting case.

External Control Signal Connection

7.6.5 Error output

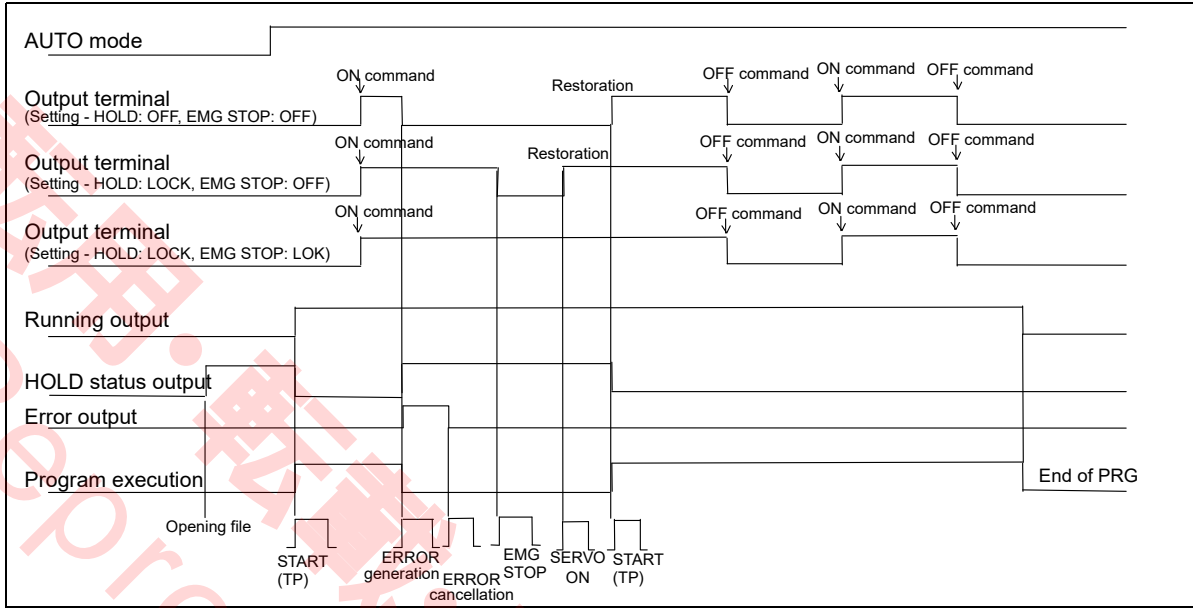

Note

The chart is drawn as positive logical setting case.

7.7 Connecting to the sequencer card

• Terminal part

- Since connector terminals are employed, they can be removed from the board.
- Peel off lead wire cover from **about 7 mm** from the end and wire it to the terminal with precision negative (-) driver. (Tightening torque: 0.5 N•m -0.6 N•m)
- Applicable wire: 0.2 mm²-2.5 mm² (AWG24 - AWG12)

• Connector part

Soldering type connector is equipped.

Sequencer card

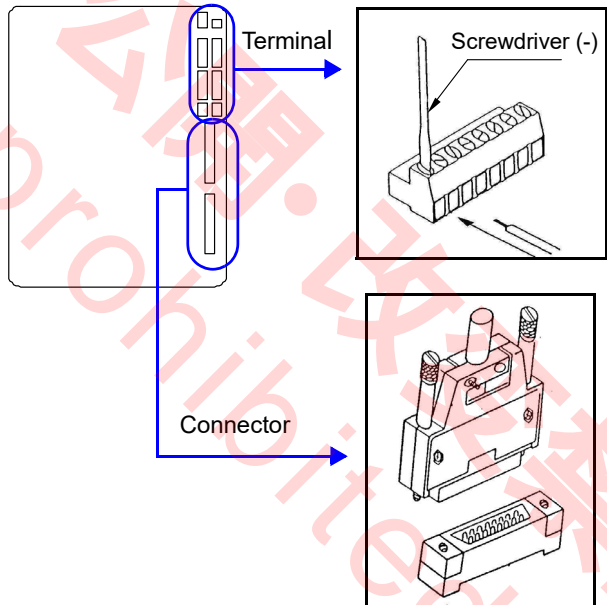

Applicable connectors

Connection method	INPUT, OUTPUT	Note
Soldering (Provided)	FCN361J040AU (connector) FNC360C040B (cover)	AWG23 or below
Crimping *	FCN363J040 (housing) FCN363J-AU (contact) FNC360C040B (cover)	AWG24 to AWG28 Coated, φ 1.2 mm or less
Pressure welding *	FCN367J040-AU/F	Flat cable Pitch: 1.27 mm, AWG28 (Stranded wire)

Note

If crimping or pressure welding type is applied, special tools need to be prepared.

7.8 External interface, External memory

7.8.1 SD Memory Card slot (Teach Pendant)

The teach pendant is equipped with a SD memory card slot. Open the cover at the bottom of the teach pendant to access the SD memory card slot. Open the cover and attach the memory card to it to use.

SD memory card	
Recommended product: (Product of Panasonic)	
Part No.:	RP-SDL series
It supports SD memory (maximum capacity 2 GB) and SDHC memory (maximum capacity 32 GB). (SD cards of SDXC standard are not supported.)	

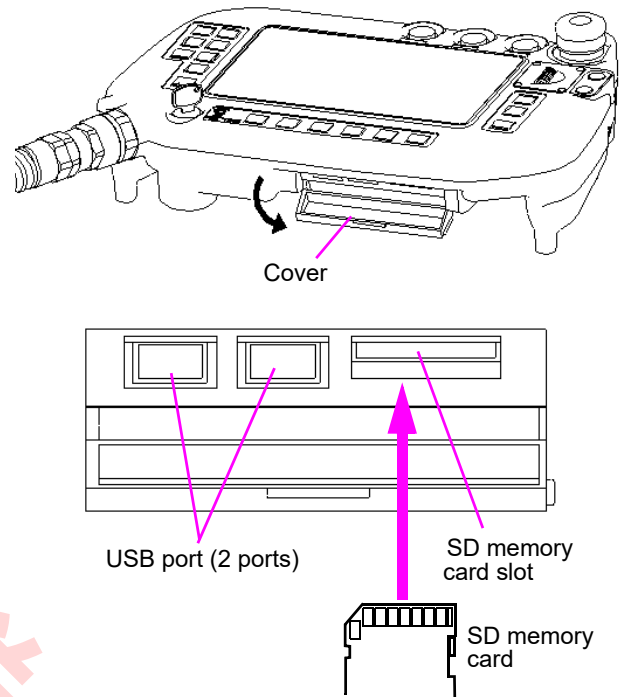

7.8.2 USB port

The teach pendant is provided with two USB ports on the left side of the SD memory card slot. You can connect a USB-compatible keyboard or memory when you use Windows CE.

- Operation confirmed USB memory

Manufacturer	Product number	Capacity
BUFFALO	RUF3-K8GA	8 GB
GREEN HOUSE	GH-UFD4GN	4 GB

<Usage note for USB port>

- The port supports USB 2.0 but does not support Hi-Speed USB.
- Applicable devices for the port are keyboard and memory.
- Depending on the type of keyboard, some functions, such as multimedia, are not available.

7.8.3 SD Memory Card slot (Main CPU card)

(1) Recovery SD memory card slot

It is a slot for TP version auto matching function and Scheduled backup function.

“TP version auto matching function” is available with the software version 9.00 or higher.

(2) User SD memory card slot

It is a slot for optional software. No card is set in the slot at shipment.

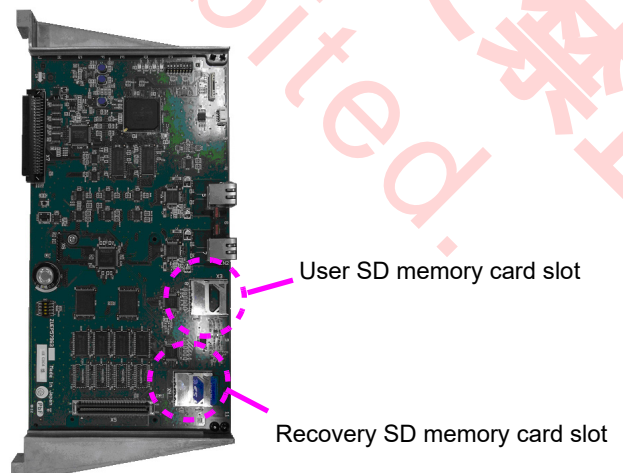

7.9 Welding voltage/current monitor

In case of using welding voltage/current monitor function, use the provided welding voltage/current monitor terminals.

- Connecting to the monitor terminals
 - (1) Remove the terminal cover at the lower part of the controller front panel.
 - (2) The monitor terminal is located on the right side of the output terminal.
 - (3) In the same manner as output cable, lead the cable to connect the external device and the monitor terminal from the underside of the power.
 - (4) Re-install the output terminal cover back in place to complete.

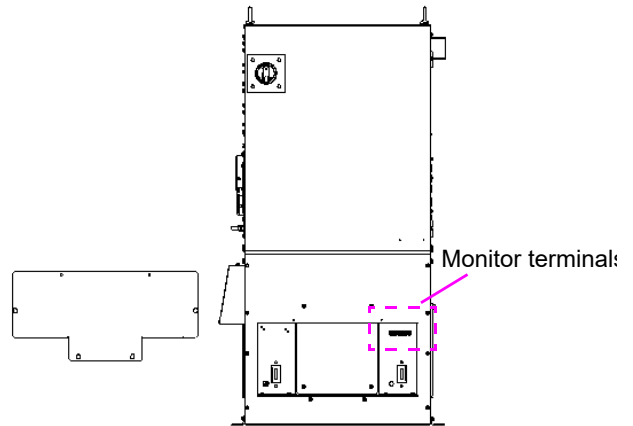

- Layout and functions of the monitor terminals

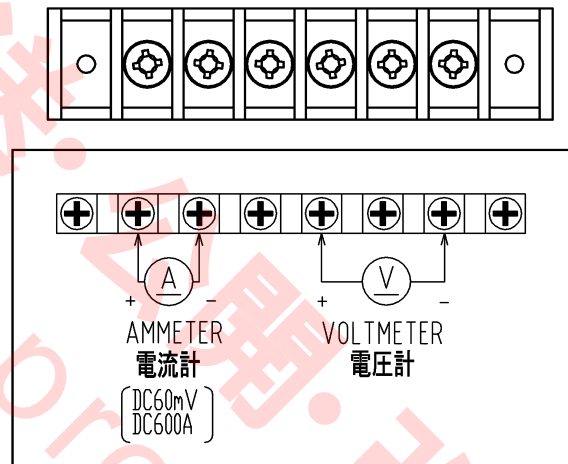

Terminal name	Function
+ (A) - Welding current monitor terminal	Connect a DC ammeter to between these terminals to monitor welding amperage. (Output terminal from the shunt resistor 600 A/ 60 mV.)
+ (V) - Welding voltage monitor terminal	Connect a DC voltmeter to between these terminals to monitor welding voltage.



Note

Make sure to connect a DC ammeter and DC voltmeter individually.

8. Maintenance and Inspection

 WARNING	
	Risk of Electric Shock Disconnect and lockout main power before servicing equipment. More than one disconnect switch may be required to de-energize the equipment before servicing.
 CAUTION	
Maintenance and inspection work must be performed by qualified personnel who have completed the appropriate training programs and also well understand the contents.	

8.1 Inspection schedule

Maintenance and inspection works are inevitable to ensure full functions and performance of the robot and at the same time to ensure safety during operation.

- (1) Refer to the table in the next page for the check items.
- (2) Since the inspection intervals are set according to standard operation hours, apply either months or hours whichever is shorter as the standard. In case of operation on two shifts, the every 500-hour inspection shall normally be performed every 1.5 months. Hours correspond to time while the controller is in the ON state.
- (3) It is recommended to have the overall inspection including overhauls specified by us at the time of every 2 000-hour inspection. If you enter into a periodical inspection contract with our company, our periodical inspections will start with a 2 000-hour (annual) inspection.

Inspection schedule
● Daily inspection
● Every 500 hours (or every third month)
● Every 2 000 hours (or every year)
● Every 4 000 hours (or every second year)
● Every 6 000 hours (or every third year)
● Every 8 000 hours (or every fourth year)
● Every 10 000 hours (or every fifth year)

Note

Inspection of the product is available as fare-paying service. For details, please contact Panasonic representatives.

8.2 Daily check

◆ Inspections before turning on the power

	Parts	Item	Service	Remarks
1	Ground cable Cables	<ul style="list-style-type: none"> Looseness Breaking or damage of wire 	<ul style="list-style-type: none"> Re-tightening. Replacement 	
2	Manipulator	Attachment of spatter or dust.	Removal of spatter or dust	Do not blow them off with compressed air. Dust or spatter may enter the clearance or inside of the cover, resulting in damage to the robot.
		Looseness	Re-tightening	Consult our service section if causes are not clear.
3	Safety fence	Damage	Repair	
4	Welding torch nozzle, tip	<ul style="list-style-type: none"> Attachment of spatter. Wear at the tip hole 	<ul style="list-style-type: none"> Removal of spatter. Replacement 	Be sure to replace with genuine parts.
5	Controller	Attachment of spatter/dust.	Removal of spatter/dust.	
		Clogged filter.	Clean/replace filter ^(*)	
6	Working area	Tidiness		

Note

^(*) : About filter at the air inlet fan

The air inlet fan at the side panels of the welding power source unit is covered with a filter.

- Clean the filter periodically. And remove dust and/or spatter attached to the filter. Using the controller with clogged filter may degrade its cooling performance of the fan, and performance of the robot will be deteriorated, as a result, the "Temperature error" may occurs.
- In case of "Temperature error"(W1210, W1220), check the filter and clean or replace it as necessary. Adhesion of dust to the cooling fan of the built-in welding power unit reduces cooling performance, which, as a result, can cause the "Temperature error". In that case, clean the cooling fan.
(If the error recurs after cleaning the cooling fan, please consult Panasonic representatives.)

● How to replace filter

- Loosen the fixing screw of the filter fitting. Then open the filter fitting and remove the filter.
- Insert a new filter into the filter fitting, and then close the filter fitting. Then tighten the filter fitting fixing screw.

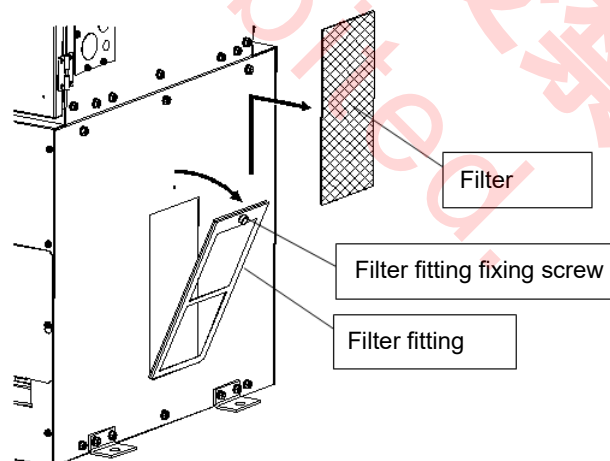
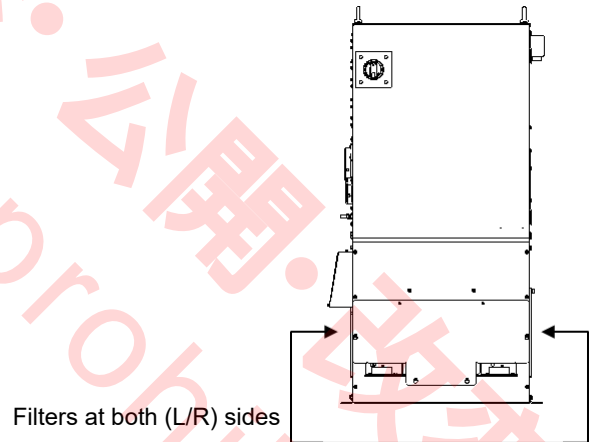

◆ Inspections after turning on the power

	CAUTION	Check to confirm that no personnel are present within the robot work envelope before turning on the power.
---	----------------	--

	Parts	Item	Service	Remarks
1	Emergency stop switch	After turning on the servo power, the servo power goes off immediately after turning on the emergency stop switch.	If not, • Repair • Consult us if causes are not clear.	Do not use the robot unless the switch is repaired.
2	Manipulator	Each axis of the robot makes steady and smooth motions (no abnormal vibration, noise or looseness) in manual and operation mode.	If not, consult us if causes are not clear.	Do not use the robot unless the manipulator is repaired.
3	Fan	Cooling air inlet fan of the controller rotates. No attachment of dust on the fan.	If not, clean the fan.	Be sure to turn off the power to the controller before cleaning the fan.
4	Controller	No abnormal vibration, noise or odor from the built-in welding power source	If not, consult us if causes are not clear.	Do not use the robot unless the manipulator is repaired.

Note

The fan for the built-in welding power source (2 pcs. on the front panel side) may not rotate immediately after power on. It starts rotation with increasing temperature of the built-in welding power source after starting actual operation. It stops rotation when the temperature of the built-in welding power source decreases after stopping actual operation.

8.3 Periodical check

Interval						Item	Inspection and service
3 mth	1 yr.	2 yr.	3 yr.	4 yr.	5 yr.		
○						Screws at covers	Check tightness and re-tighten if necessary.
○						Connecting cable connectors	Check tightness and re-tighten if necessary.
○						Other consumable components	Replace with new one if necessary.

Note

- Electromagnetic contactors or cooling fans:
Please treat them as consumable when performing periodical check and maintenance work. Those components have a certain life cycle electrically and mechanically.
- For details, please consult our service section. If you have a periodical inspection contract with our company, our periodical inspections will start with a 2 000-hour (annual) inspection.
- For inspection of the manipulator, please refer to the operating instructions of the manipulator.

8.4 Precautions for withstand voltage test and insulation resistance measurement

This product uses semiconductor components such as transistor. Executing withstand voltage test or insulation resistance measurement casually may cause serious physical injury or mechanical failure. In case of necessity, contact our sales distributors or Panasonic representatives.

転用・転載・転送・公開・改変禁止
Reproduction prohibited.

9. Disposal of this product

After disposal of this product, data in the controller might go to third parties.

To prevent this, perform **All Clear** in **Memory clear** menu before disposal. For details, refer to “Operating Instructions [Operation]”.

Reproduction prohibited. 転載・転送・公開・改変禁止

10. Repair Parts List

10.1 Controller

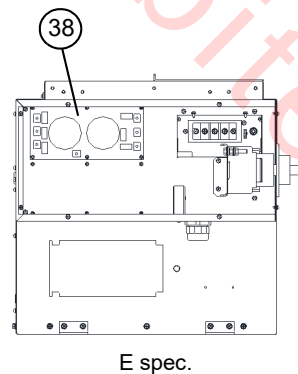
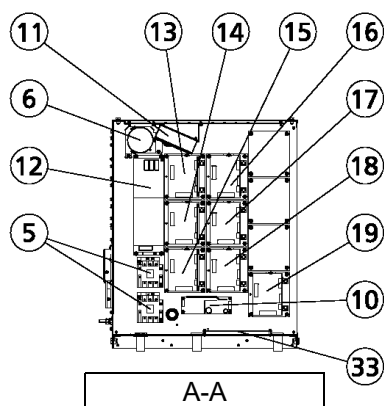
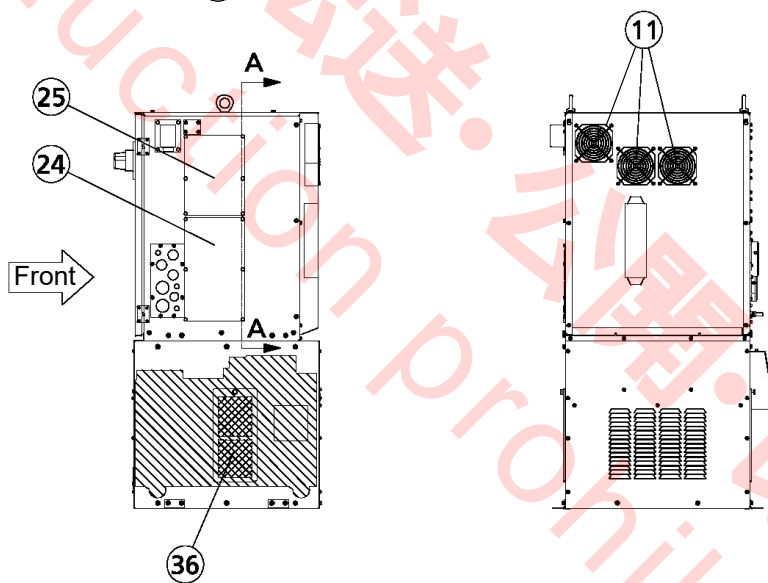
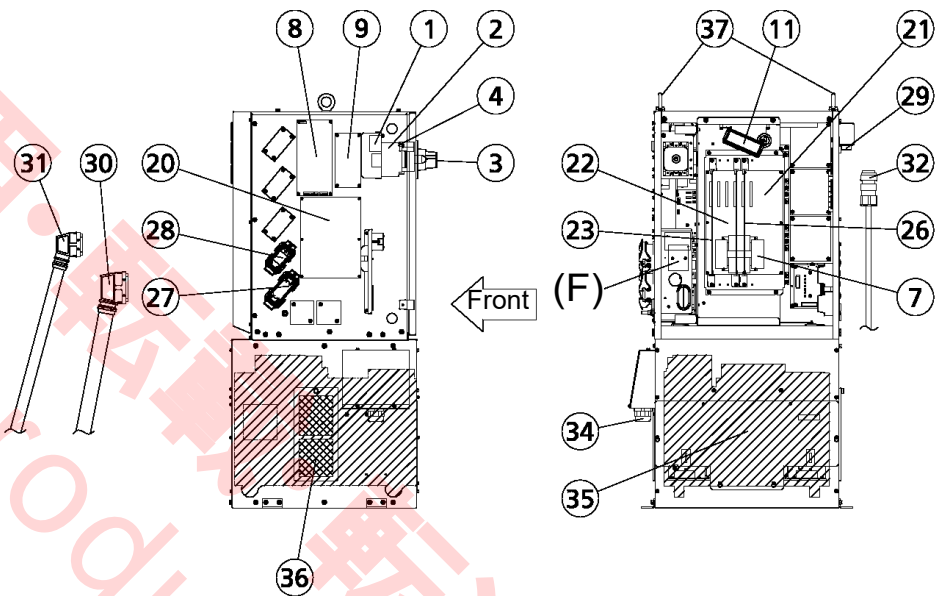

Repair Parts List

No.	Description		Part number	Repair part order number	Q'ty	Note	Safety part	Class
1	Anti-surge Parts		AEB41080	AEB41080	1			D
2	Breaker	T / Y spec.	B32AA3P30WAR	YAB112	1		O	C
		U spec. (Other than LA-1800)	MTNC000040AA	MTNC000040AA	1		O	C
		U spec. (LA-1800)	MTNC000969AA	MTNC000969AA			O	C
		E spec. (Other than LA-1800)	MTNC000024AA	MTNC000024AA	1		O	C
		E spec. (LA-1800)	MTNC000968AA	MTNC000968AA	1		O	C
3	Handle		BZ6V10D	YAB113	1			C
4	Terminal cover		BW9BTAAS3W	YAB114	1	2 pcs/set, Attach to the breaker		D
5	Magnetic switch		SDN35DC24V	YAB115	2			C
6	Electrolytic capacitor		45LSU3300MTY	YABD281	1			C
7	Transformer		UTU5315	UTU5315	1			D
8	DC Power Supply		ZWQ130-5224L	YAB130	1			C
9	DC Power Supply		LFA150F24J1	YAB179	1			C
10	DC Power Supply		MTNC000728AA	MTNC000728AA	1	T/Y Specification		C
			LFA75F15J1	YAB119	1	E/U(R) Specification		C
10	Cooling Fan	Other than YA-2GC261	UT125C	YKAD34	4			B
		YA-2GC261	UT125C	YKAD34	5			B
12	Servo Power		AED01283	AED01283	1			C
13 14 15 16 17 18	Amplifier	YA-1WCR61	AED01316	AED01316	2	for RT, FA		C
			AED01317	AED01317	1	for UA		C
			AED01318	AED01318	3	for RW, BW, TW		C
		YA-1WCR81	AED01317	AED01317	1	for RT		C
			AED01319	AED01319	1	for UA		C
			AED01316	AED01316	1	for FA		C
			AED01322	AED01322	1	for RW		C
			AED01318	AED01318	2	for BW, TW		C
		YA-1ZCR81	AED01317	AED01317	1	for RT		C
			AED01319	AED01319	1	for UA		C
			AED01316	AED01316	1	for FA		C
			AED01323	AED01323	1	for RW		C
			AED01322	AED01322	1	for BW		C
		YA-2ECR81	AED01318	AED01318	2	for TW		C
			AED01316	AED01316	3	for RT,UA, FA		C
		YA-2GC261	AED01322	AED01322	3	for RW, BW, TW		C
			AED01319	AED01319	2	for RT, UA		C
			AED01317	AED01317	1	for FA		C
AED01323	AED01323		2	for RW, BW		C		
AED01322	AED01322		1	for TW		C		
19	Feeder Amplifier		AED01291	AED01291	1	for Feeder (50 W)		C
			AED01284	AED01284	1	for Feeder (100 W)		C
			AED01285	AED01285	1	for Feeder (150 W, 200 W)		C
20	Power Card		ZUEP5850	ZUEP5850	1			C
21	Backplane card		ZUEP5806	ZUEP5806	1			C
22	Main CPU Card		ZUEP5796	ZUEP5796	1			C
23	Servo CPU Card		ZUEP5845	ZUEP5845	1			C

Repair Parts List

No.	Description		Part number	Repair part order number	Q'ty	Note	Safety part	Class
24	Sequencer Card	T/Y/U spec.	ZUEP5789	ZUEP5789	1	Open collector (NPN) output		C
		E spec.	ZUEP5826	ZUEP5826	1	Open collector (PNP) output		C
25	Safety Card		ZUEP5808	ZUEP5808	1			C
26	Welding Control Card		ZUEP5799	ZUEP5799	1			C
27	Motor panel harness		AWC32958	AWC32958	1			C
28	RE panel harness		AWC32959	AWC32959	1			C
29	TP harness		AWC32875	AWC32875	1			C
30	Motor Cable		AWC32960LN	AWC32960LN	1	Standard: 5 m		C
31	RE Cable		AWC32961LN	AWC32961LN	1	Various lengths are available up to 30 m. For details, please contact Panasonic representatives.		C
32	TP Cable		AWC32876LT	AWC32876LT	1	Standard: 10 m Various lengths are available up to 30 m. For details, please contact Panasonic representatives.		B
33	Welding Power Card	YA-1TD351T00	ZUEP5779__A1 ^(*1)	ZUEP5779__A1 ^(*1)	1			C
		YA-1TD351E03 YA-1TD351U01	ZUEP5905__A1 ^(*1)	ZUEP5905__A1 ^(*1)	1	For 200 W pull feeder type		C
		YA-1TD351T10	ZUEP5989__A1 ^(*1)	ZUEP5989__A1 ^(*1)	1			C
		YA-1TD351E13 YA-1TD351U11	ZUEP5990__A1 ^(*1)	ZUEP5990__A1 ^(*1)	1	For 200 W pull feeder type		C
34	Cord lock		EBG2836BK	YAAD62	1			D
35	Welding Power Unit ^(*2)	T/Y spec.	YA-1TD351T00	AEU01590	1	200 VAC/220 VAC spec.		C
			YA-1TD351T10	WSAEU00231ZZ	1	200 VAC/220 VAC spec.		C
		E spec.	YA-1TD351E03	WSAEU00093ZZ	1	200 VAC spec.		C
			YA-1TD351E13	WSAEU00248ZZ	1	200 VAC spec.		C
		U spec.	YA-1TD351U01	WSAEU00018ZZ	1	200 VAC spec.		C
			YA-1TD351U11	WSAEU00249ZZ	1	200 VAC spec.		C
36	Filter		AKC41124	AKC41124	2			C
37	Eyebolts ^(*3)		XVN12FJ	XVN12	2	M12		B
38	Filter card		ZUEP5900	ZUEP5900	1	E spec.		C
(F)	Fuse holder		K3GZ3YG00001	K3GZ3YG00001	1			C

(*1) When you order a card, make sure to use the complete repair part order number including the alphanumeric characters at the end, such as A1 and B1, if any.

The card of the part number without the alphanumeric characters is not compatible with the one with the alphanumeric characters.

The underline “_” in a part number if any represents any give alphanumeric character.

(*2) Replacement of the welding power unit is available only by unit.

(*3) Eyebolts are important safety parts. When they are lost or broken, purchase Panasonic genuine eyebolts for your safety.

<Class>
 A: Consumable parts, rather short replacement cycle.
 B: Assemblies and parts of high frequency in motion.
 C: Important electric parts.
 D: Parts rather long replacement cycle.

◆ List of fuses

No.	Installation location	Part code	Part number	Repair part order number	Q'ty	Note
1	Fuse holder ((F) refer to "10.1 Controller")		250VTLLC15A	YABD93	3	15 A (T/Y spec.)
			FNM15	YABD288	3	15 A (E spec.)
2	AED01283 (ZUEP5801)	F1,F2	ST4-0.5A	YZAD179	2	0.5 A (Servo power card)
3	ZUEP5850	F2	ST4-3AN1	YZA/EEJ002	1	3 A (Power card)
4	ZUEP5789(T/Y/U) ZUEP5826(E)	F1			1	3 A (Sequencer card)
5	ZUEP5808	F1			1	3 A (Safety card)
6	ZUEP5850	F3,F4	ST4-8AN1	YZAD217	2	8 A (Power card)
7	ZUEP5850	F1	CES14-12AN2	YABD264	1	12 A (Power card)
8	ZUEP5755	F1	ST4-5AN1	YZAD183	1	5 A (Inside welding power source)
9	Fuse holder	F4,F5,F6	ST4-3AN1	YZA/EEJ002	3	3 A (Inside welding power source)

10.2 Teach pendant

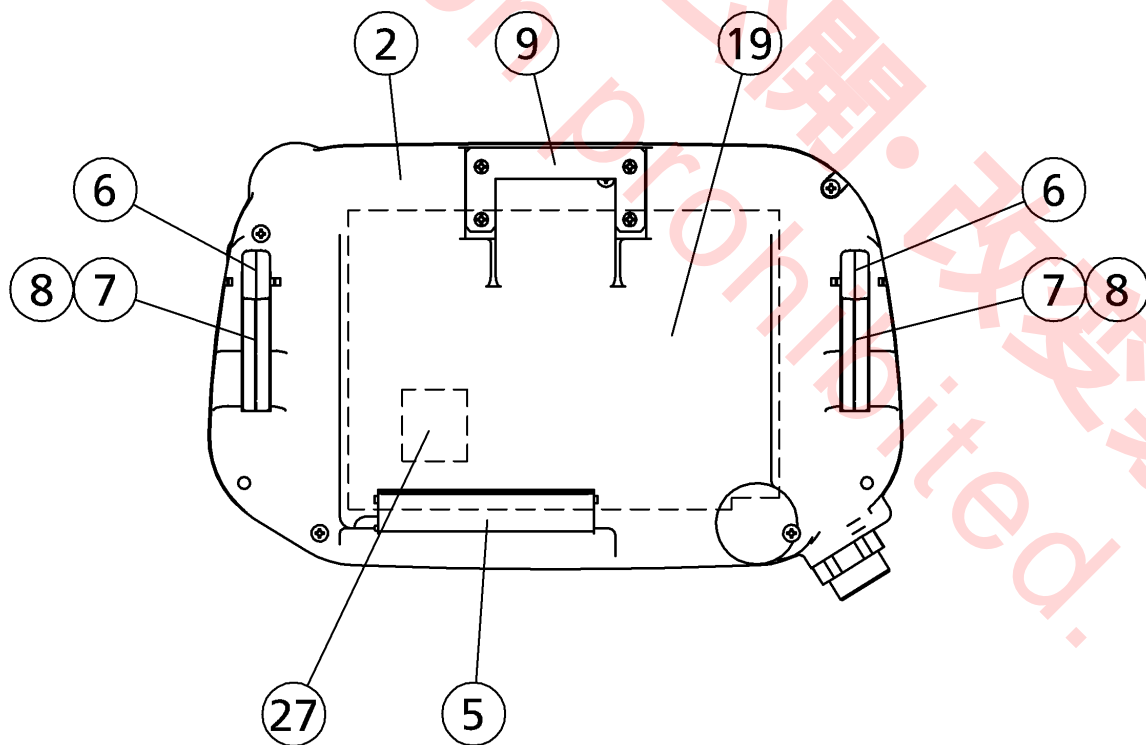
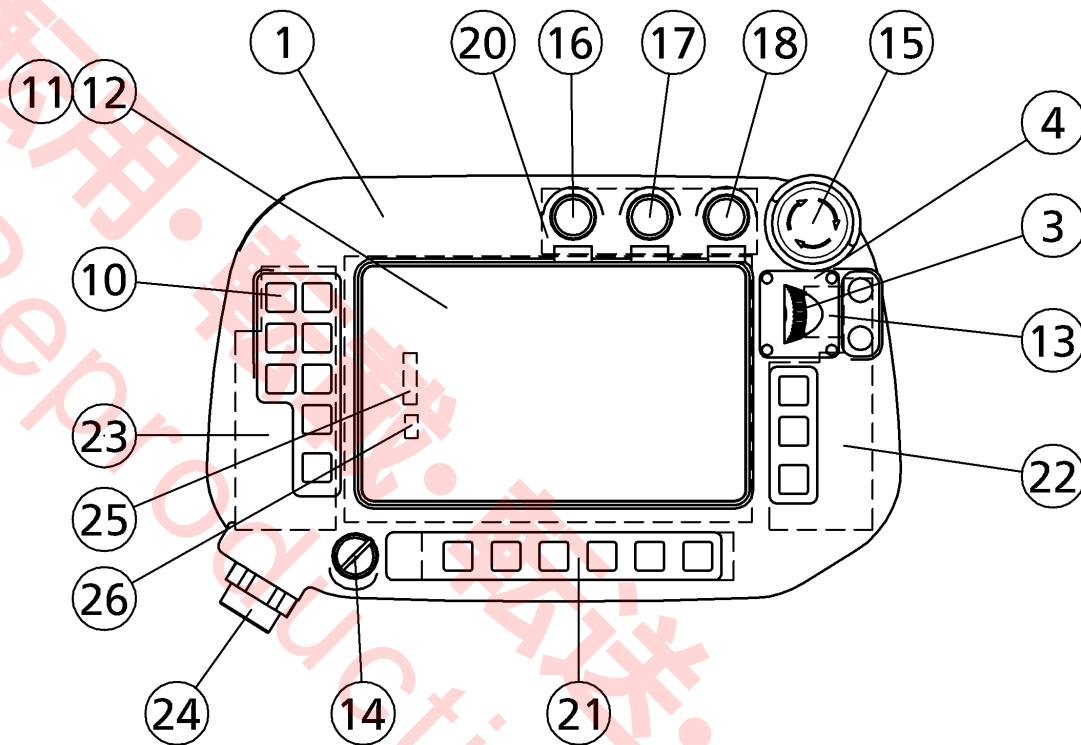

Repair Parts List

No.	Description	Part number	Repair parts order number	Q'ty	Note	Safety part	Class
1	Case body	AKH41014	AKH41014	1			D
2							
3	Dial	AKC31006	AKC31006	1			D
4	Jog cover	AKC31061	AKC31061	1			D
5	Cover	AKC31060	AKC31060	1			B
6	Trigger	AKC31009	AKC31009	2			B
7	Lever 1	AKC31002	AKC31002	2			B
8	Lever 2	AKC31003	AKC31003	2			D
9	TP hanger	AKC41238	AKC41238	1			B
10	Key Sheet	AKP32009	AKP32009	1	A set of three kinds.		B
11	LCD Cover	AKK32082	AKK32082	1			B
12	LCD	MTNS000067AA	MTNS000067AA	1			B
13	Encoder	RE21BARE100A	YABD209	1			B
14	Key Switch	AS6M2KT2PA	YAB120	1	With 2 keys (YAB178)		B
15	Emergency Stop Switch	XA1EB3U02TR	YAB224	1		O	B
16	Push button switch	A165TGYMNA1	YABD40	1			B
17	Push button switch	A165TWMNMA2	YAW173	1			B
18	Push button switch	A165TGYMNA3	YAB122	1			B
19	TP CPU Card	ZUEP5800	ZUEP5800	1	For AUR01060		C
		ZUEP5947	ZUEP5947		For WSAUR00002ZZ		
20	TP UP card	ZUEP5716	ZUEP5716	1			C
21	TP Low Card	ZUEP5811	ZUEP5811	1			C
22	TP Right Card	ZUEP5810	ZUEP5810	1			C
23	TP Left Card	ZUEP5809	ZUEP5809	1			C
24	TP harness	AWC32878	AWC32878	1			B
25	TP LCD harness	AWC42538	AWC42538	1			D
26	TP LED harness	AWC42537	AWC42537	1			D
27	TP system software	WSAYF00039	WSAYF00039	1	For AUR01060		B
		WSAYF00040	WSAYF00040		For WSAUR00002ZZ		

<Class> A: Consumable parts, rather short replacement cycle.
 B: Assemblies and parts of high frequency in motion.
 C: Important electric parts.
 D: Parts rather long replacement cycle.

10.3 Operation Box

T / Y spec.	Optional
E / U spec.	Standard

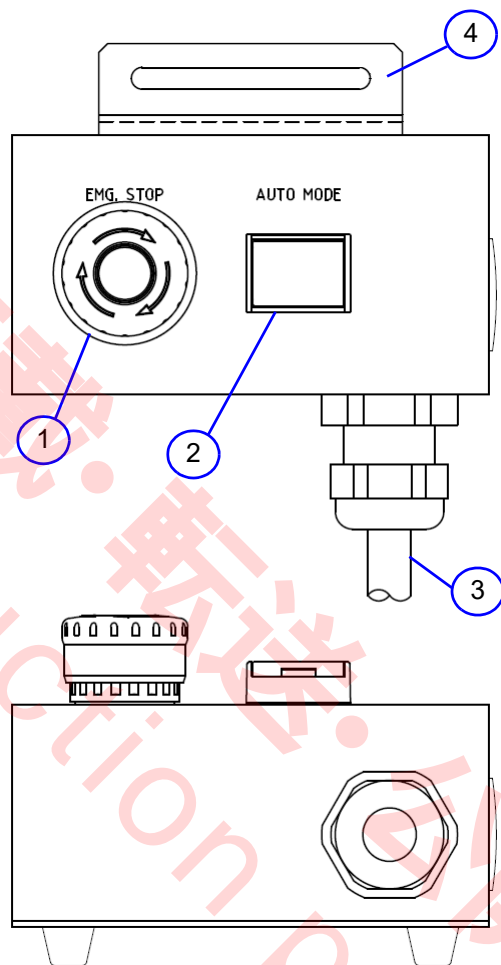

<Class> A: Consumable parts, rather short replacement cycle.
 B: Assemblies and parts of high frequency in motion.
 C: Important electric parts.
 D: Parts rather long replacement cycle.

No.	Description	Part number	Repair parts order number	Q'ty	Note	Class	Safety part
-	Operation box	AEU01610	AEU01610	1		D	
1	Emergency Stop Switch	XA1EB3U02TR	YAB224	1		B	Yes
2	Push Button Switch	A165LJWM24DN	YABD204	1		B	
3	Cable	AWC32923LP	AWC32923LP	1	6 m	B	
4	Fixing Metal	AKC41016PA	AKC41016PA	1		D	

Note

Safety parts are important for safe machine operation.
 Always use correct parts in correct locations.

11. Critical Raw Material (CRM) List

CRM	Description	Part number	Note
Light Rare Earth Elements	Motor	TS4602N3030	Included in feeder (50 W).
		TS4606N3337	Included in feeder (100 W).
		TS4604N3022	Included in feeder (150 W).
		MTNM000185AA	Included in feeder (200 W).

12. Circuit Diagram

12.1 Controller 1

轉用・轉載・轉送・公開・改裝禁止
Reproduction prohibited.

12.2 Controller 2

轉用・轉載・轉送・公開・改裝禁止
Reproduction prohibited.

12.3 Welding power source

< YA-1TD351T00/ YA-1TD351E03/ YA-1TD351U01 >

轉用・轉載・轉送・公開・改裝禁止
Reproduction prohibited.

12.4 Welding power source

< YA-1TD351T10/ YA-1TD351E13/ YA-1TD351U11 >

転用・転載・転送・公開・改変禁止
Reproduction prohibited.

13. Label location

13.1 Location of labels

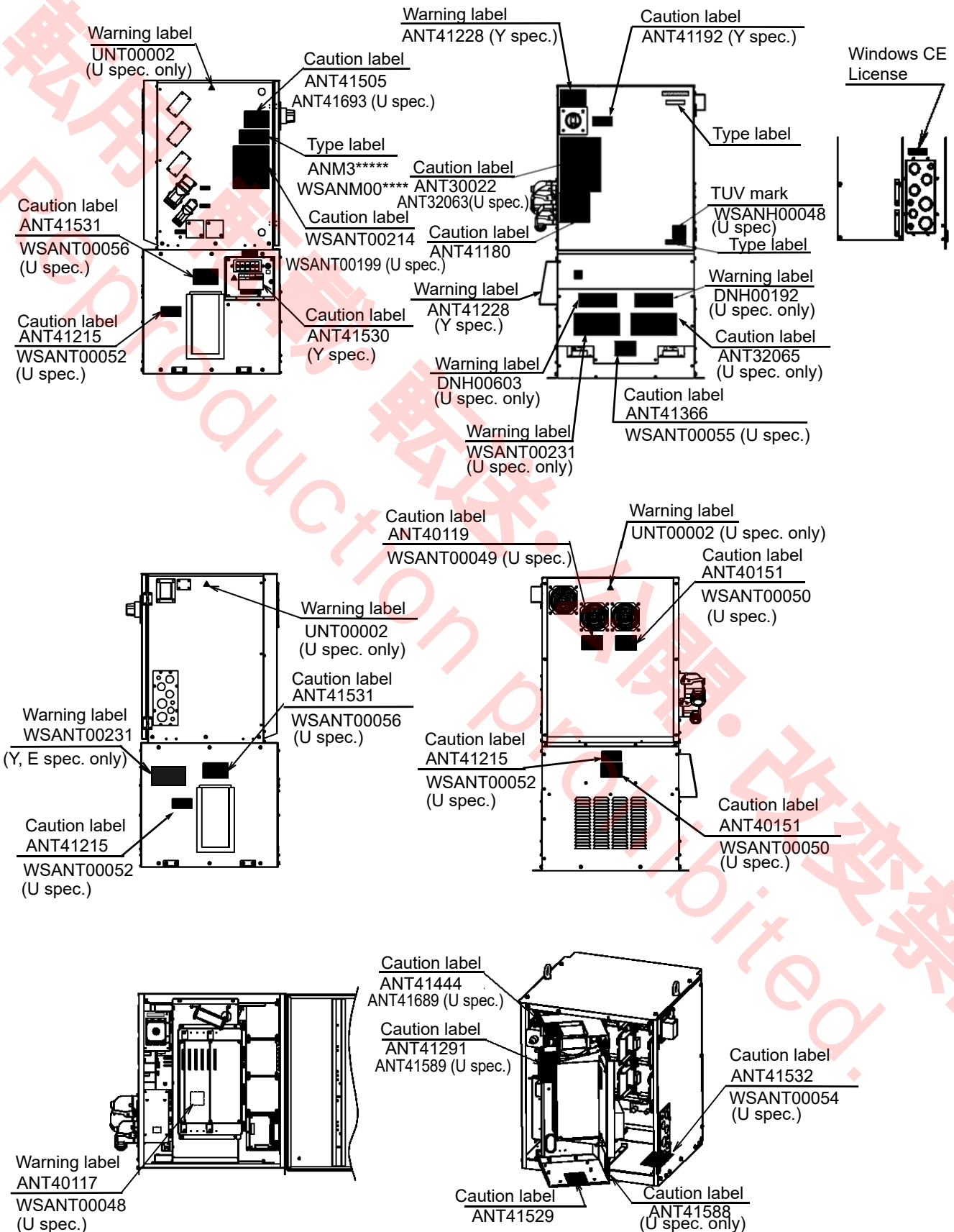

- Only for U specifications

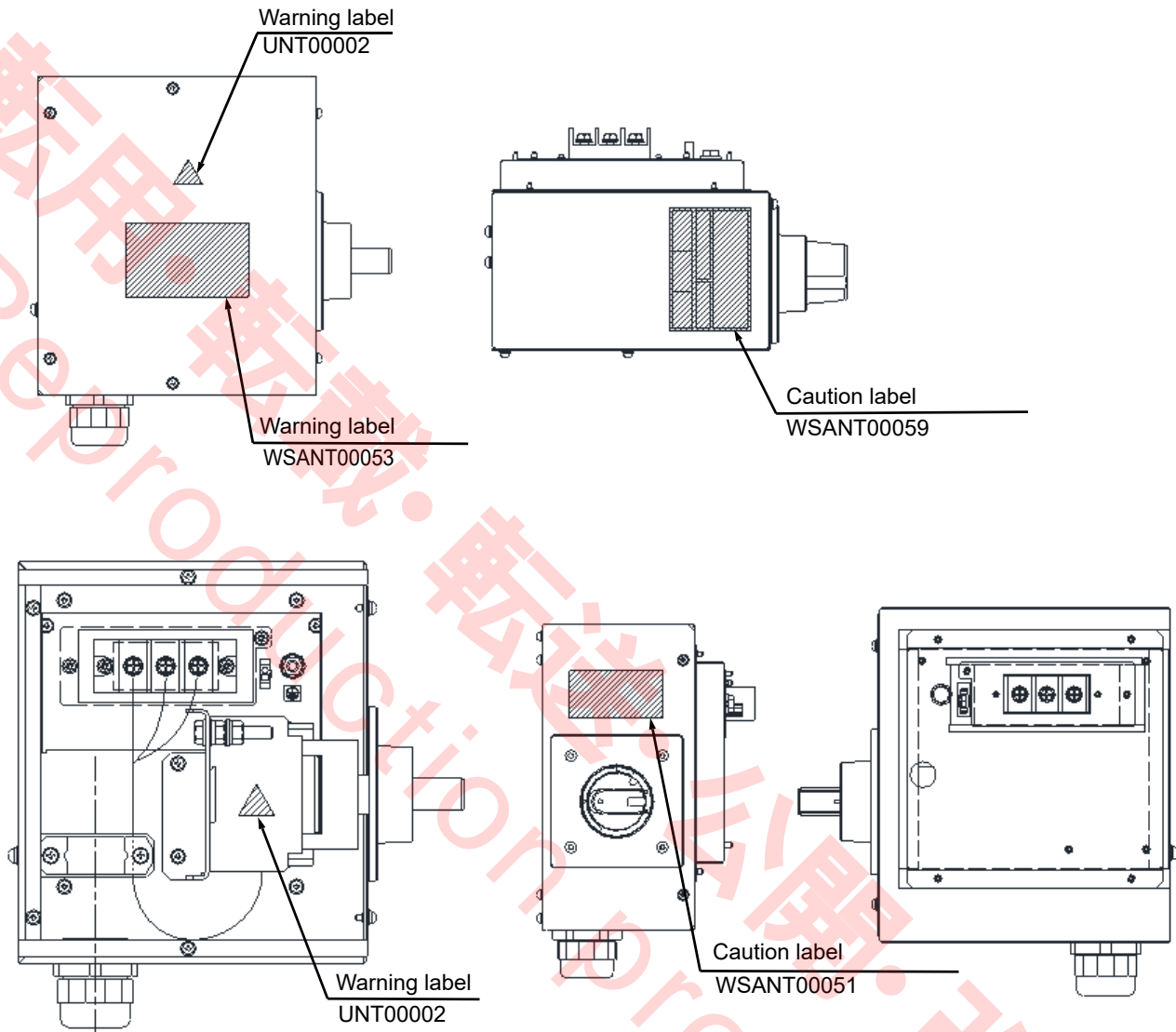

Label location

- Only for E specifications (Other than LA-1800)

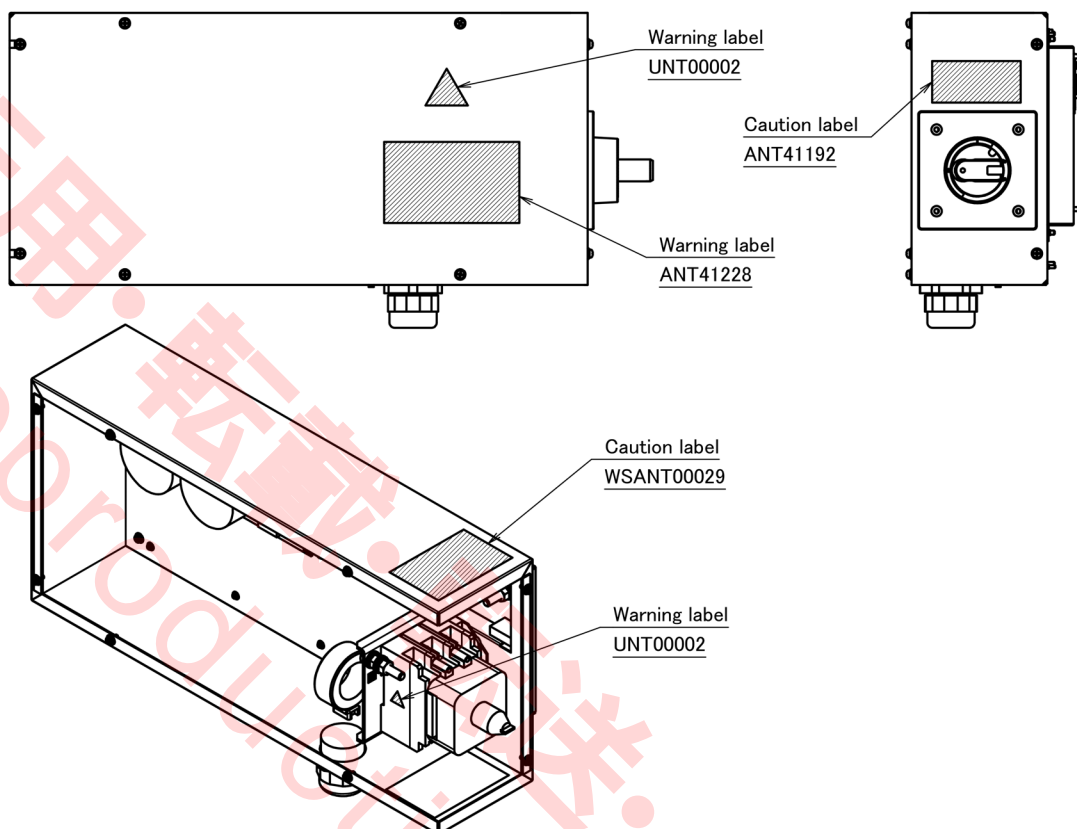

- Only for E specifications (LA-1800)

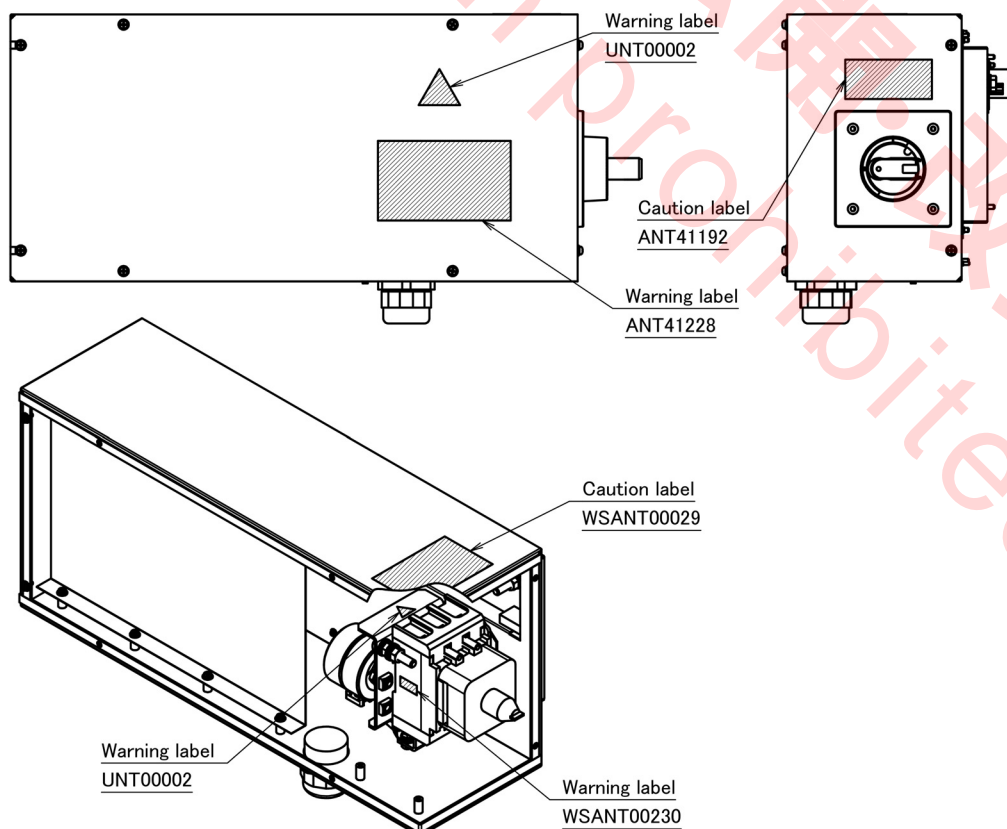

13.2 Labels

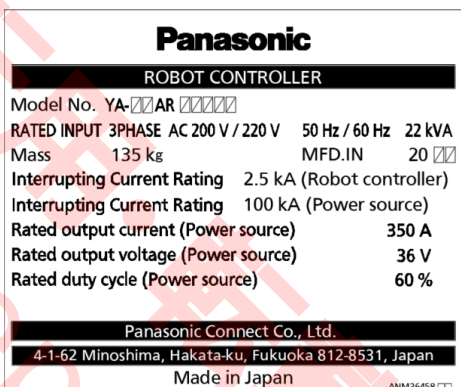

<Type label - ANM*****>
(Y spec. only)



<Type label - WSANM00096>
(E spec. only)



<Type label - WSANM00096>
(LA-1800 E spec. only)

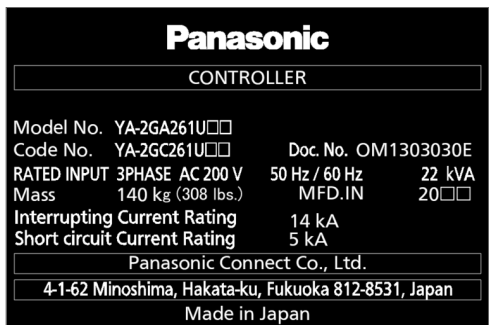

<Type label - WSANM00096>
(U spec. only)

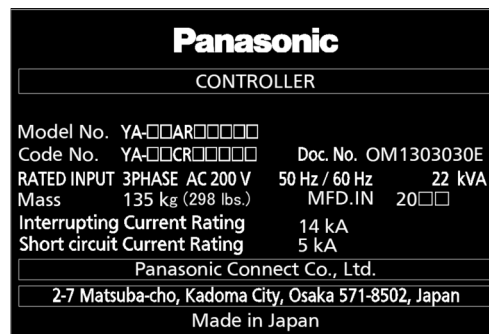

<Type label - WSANM00096>
(LA-1800 U spec. only)

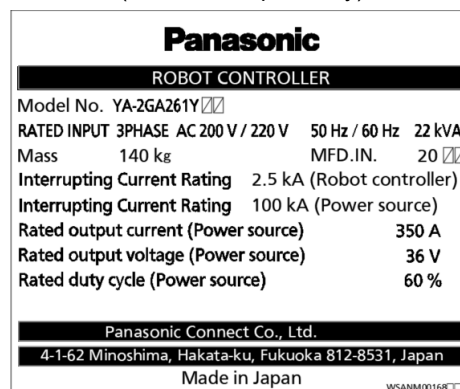

<Type label - WSANM00168>

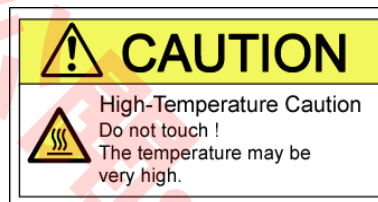

< Caution label - ANT40151 >

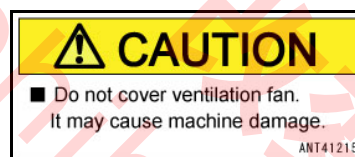

< Caution label - ANT41215 >

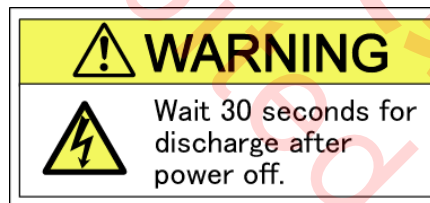

< Warning label - ANT40117 >

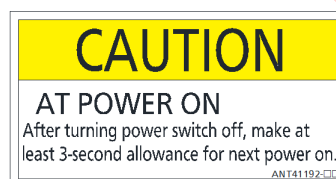

< Caution label - ANT41192 >

⚠ CAUTION	⚠ 注意
GROUNDING <ul style="list-style-type: none"> Make reliable ground connection for the robot independently from the protective earth terminal of the robot controller. Use protective conductor more than AWG #6 (14 mm²). As for thickness of protective conductor for another machine, follow indication for each machine. Grounding work must be done by the qualified personnel. DAILY CHECK <ul style="list-style-type: none"> Check looseness and disconnection of protective conductor. 	接地工事 <ul style="list-style-type: none"> 制御装置の保護接地端子にロボット単独でD種接地工事を行って下さい。 保護接地線は14 mm²以上の線をご使用下さい。 他の装置の保護接地線の太さは、その装置の指示に従って下さい。 D種接地工事は、必ず専門の電気工事士により施工して下さい。 保護接地線の日常点検 <ul style="list-style-type: none"> 保護接地線は日常点検し、はずれたり、断線したりしていないか確認して下さい。
<p style="text-align: center;">EARTH LINE OF FACTORY 工場の保護接地線</p> <p style="text-align: center;">Make reliable ground connection for the robot independently. ロボット単独のD種接地</p> <p style="text-align: center;">AWG #6 (14 mm²) or more (Attached) 14 mm²以上 (付属)</p>	

< Warning label - WSANT00214 >

⚠ WARNING	
Carefully read operation manual before installation	
	Do not open the door. Electric shock can kill
	Do not enter the robot work envelope while robot is operating.
⚠ CAUTION	
Encoder backup battery Replace battery every 2 years. Operating conditions will vary the lifetime of battery. Refer to operation manual.	

< Warning label - ANT30022 >

⚠ CAUTION ATTENTION
High-Temperature Caution Do not touch! The temperature may be very high. Haute température Attention Ne pas toucher! La température peut être très haute.

< Caution label - WSANT00050 >
(U spec. only)

⚠ CAUTION ATTENTION
<ul style="list-style-type: none"> Do not cover ventilation fan. It may cause machine damage. Ne pas couvrir le ventilateur. Cela peut endommager la machine.

< Caution label - WSANT00052 >
(U spec. only)

⚠ WARNING AVERTISSEMENT
<ul style="list-style-type: none"> Wait 30 seconds for discharge after power off. Attendez 30 secondes pour le déchargement après éteindre.

< Warning label - WSANT00048 >
(U spec. only)

⚠ CAUTION
<ul style="list-style-type: none"> Make sure to install the robot controller so that no spatters or flammable substances can get in through the air inlet. Read instruction manual for the details. Clean the filter attached to the air inlet of the fan periodically In case of "temperature error", check the filter and clean or replace as necessary

< Caution label - ANT41531 >

⚠ CAUTION
During maintenance work, the movement of the rack may cause damage of wire harnesses. Don't place wire harnesses or other parts on the left side of this label.

< Caution label - ANT41532 >

⚠ 注意
挟み込み注意 手を入れるな。
⚠ CAUTION
RISK OF GETTING TRAPPED do not insert hands

< Caution label -ANT41291 >

⚠ CAUTION
Before opening the rack, be sure to disconnect four connectors (TPOW, TCOM, CAN0, CAN1) on the upper right of the backplane board.
Connectors location of the backplane board

< Caution label - ANT41529 >

CAUTION ATTENTION
AT POWER ON After turning power switch off, allow at least 3 seconds allowance for next power on. AT BRANCHE Apres avoir éteint la machine par le commutateur central, attendez au minimum 3 secondes avant de remettre en route.

< Caution label - WSANT00051 >
(U spec. only)

--

< CE/UKCA mark - WSANH00472 >

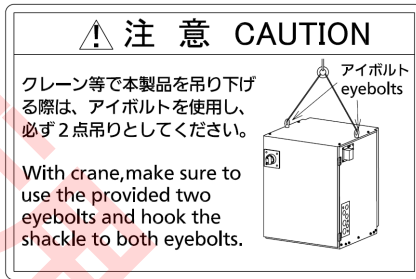

< Caution label - ANT41505 >



< Caution label - ANT41444 >

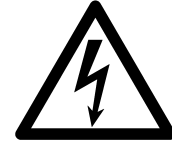

< Warning label - UNT00002 >

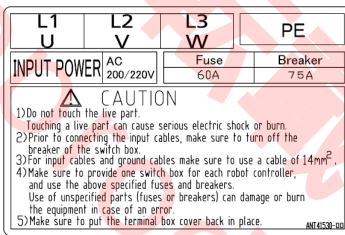

< Caution label - ANT41530 >
(Y spec. only)

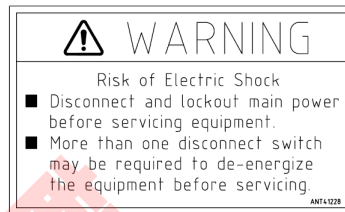

< Warning label - ANT41228 >

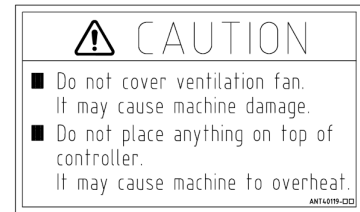

< Caution label - ANT40119 >

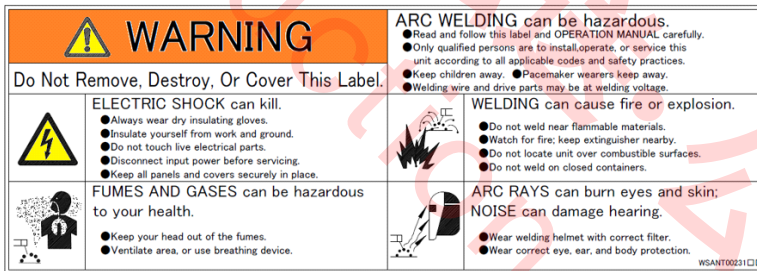

< Warning label - WSANT00231 >

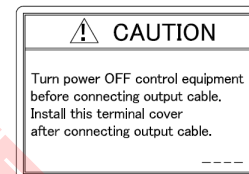

< Caution label - ANT41366 >

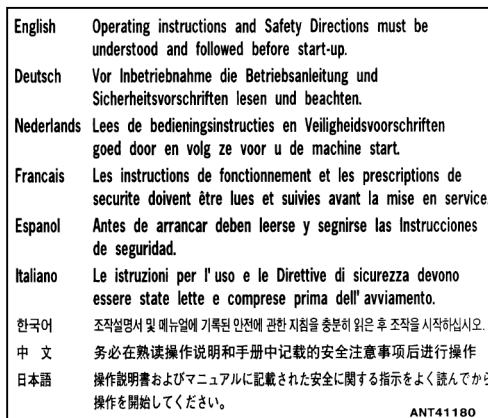

< Caution label - ANT41180 >

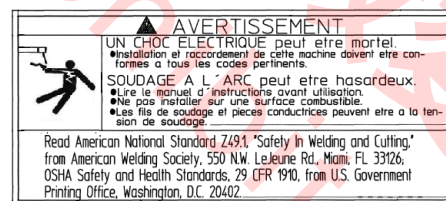

< Caution label - DNH00192 >

CAUTION	ATTENTION
GROUNDING ■ Make reliable ground connection for the robot independently from the protective earth terminal of the robot controller. ■ Use protective conductor more than AWG #6 (14 mmf). ■ As for thickness of protective conductor for another machine, follow indication for each machine. ■ Grounding work must be done by the qualified personnel. DAILY CHECK ■ Check looseness and disconnection of protective conductor.	PRISE DE TERRE ■ Établir une bonne connexion à la terre pour le robot indépendamment de la borne de masse de protection du contrôleur du robot. ■ Utilisez un conducteur de protection supérieur à AWG #6 (14 mmf). ■ Pour l'épaisseur des conducteurs de protection pour une autre machine, suivez les indications pour chaque machine. ■ Travail de mise à la terre doit être effectué par personnel qualifié. CONTRÔLE JOURNALIER ■ Contrôlez déconnexion et état fixation du conducteur de protection.
EARTH LINE OF FACTORY PRISE DE TERRE DE L'USINE 	

< Caution label - WSANT00199 >
(U spec. only)

WARNING	AVERTISSEMENT
Carefully read operation manual before installation. / Lire attentivement le manuel d'opération avant installation.	
Arc Flash and Shock Hazard Do not open the door Risk of electric shock	Risque de coup d'arc et de choc Ne pas ouvrir la porte. Risque de choc électrique.
Do not enter the robot work envelope while robot is operating.	Ne pas entrer dans la zone de travail du robot pendant qu'il est actif.
CAUTION	ATTENTION
Encoder backup battery Replace battery every 2 years Operating conditions will vary lifetime of battery Refer to operation manual.	Batterie de sauvegarde d'encodeur Remplacez la batterie toutes les 2 ans Conditions d'opérations font varier la durée de vie de la batterie. Référez au manuel d'opération.

< Warning, Caution label -ANT32063 >
(U spec. only)

ATTENTION
Risque d'être coincé: Attention pour vos mains.
CAUTION
RISK OF GETTING TRAPPED do not insert hands ANT41589-□□

< Caution label - ANT41589 >
(U spec. only)

CAUTION	ATTENTION
■ Make sure to install the robot controller so that no spatters or flammable substances can get in through the air inlet. Read instruction manual for the details. ■ Clean the filter attached to the air inlet of the fan periodically. ■ In case of "temperature error", check the filter and clean or replace as necessary ■ Placez l'armoire de commande de telle façon à ce que les substances inflammables ne puissent pas rentrer par l'entrée de la ventilation. Lisez le manuel d'instruction pour plus d'information. ■ Nettoyez le "filtre attaché à l'entrée de l'air du ventilateur" périodiquement. ■ En cas de "temperature error" contrôlez le filtre et nettoyez ou changez le si nécessaire.	

< Caution label - WSANT00056 >
(U spec. only)

ATTENTION
Avant d'ouvrir la partie pivotante, il faut brancher les quatre prises (TPOW, TCOM, CANO, CAN1) qui se trouvent en haut à droite sur le circuit imprimé de base.
Location des prises sur le circuit imprimé de base.
ANT41588-□□

< Caution label - ANT41588 >
(U spec. only)

CAUTION	ATTENTION
During maintenance work, the movement of the rack may cause damage of wire harnesses. Don't place wire harnesses or other parts on the left side of this label.	Pendant les travaux de service le mouvement du rack peut endommager le câblage. Ne montez pas de câble ou autre pièce détachée à gauche de cette étiquette.

< Caution label - WSANT00054 >
(U spec. only)

CAUTION	ATTENTION
With crane, make sure to use the provided two eyebolts and hook the shackle to both eyebolts. Assurez vous qu'on utilise les deux écrous avec bague de hissement livrés et accrochez le crochet de palan dans les deux bagues de hissement.	

< Caution label - ANT41693 >
(U spec. only)

CAUTION	ATTENTION
Don't bring fingers, hairs or clothes near the rotating section. Ne pas mettre les doigts, les cheveux ainsi que les vêtements près de la section tournante.	
ANT41689	

< Caution label - ANT41689 >
(U spec. only)

WARNING	AVERTISSEMENT
Risk of Electric Shock ■ Disconnect and lockout main power before servicing equipment. ■ More than one disconnect switch may be required to de-energize the equipment before servicing.	Risque de choc électrique ■ Déconnecter et exclure l'alimentation en électricité avant d'entretenir le matériel. ■ Plus qu'un commutateur de déconnexion pourront être nécessaire pour couper l'alimentation du matériel avant de l'entretenir.

< Caution label - WSANT00053 >
(U spec. only)

CAUTION	ATTENTION
■ Do not cover ventilation fan. It may cause machine damage. ■ Do not place anything on top of controller. It may cause machine to overheat. ■ Ne pas couvrir le ventilateur. Cela peut endommager la machine. ■ Ne rien placer sur l'armoire de commande. Cela peut causer une surchauffe de la machine.	

< Caution label - WSANT00049 >
(U spec. only)

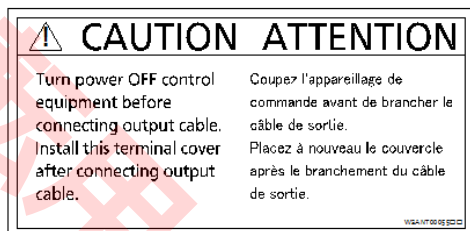

< Caution label - WSANT00055>
(U spec. only)

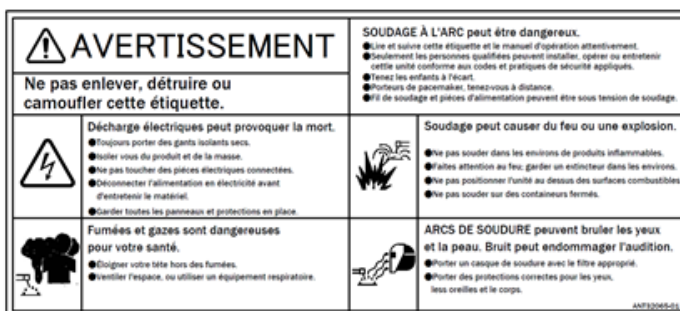

< Warning label - ANT32065>
(U spec. only)



< Warning label - DNH00603>
(U spec. only)



< TUV mark - WSANH00048 >
(U spec. only)

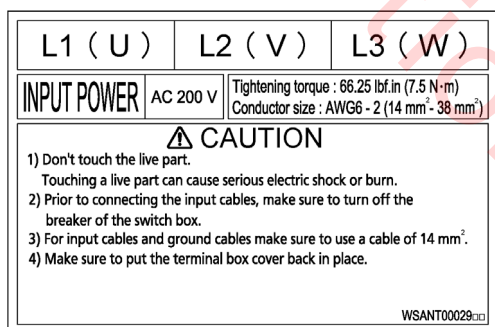

< Caution label - WSANT00029>
(E spec. only)

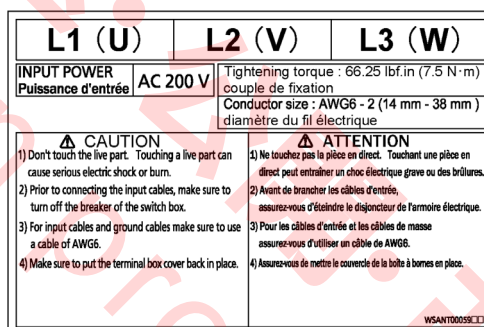

< Caution label - WSANT00059>
(U spec. only)



< Warning label - WSANT00230>
(E spec. only)

轉用・轉載・轉送・公開・改變禁止
Reproduction prohibited.



転用・転載・転送・公開・改変禁止
Reproduction prohibited.

パナソニック コネクト株式会社
〒561-0854 大阪府豊中市稲津町3丁目1番1号

Panasonic Connect Co., Ltd.
1-1, 3-chome, Inazu-cho, Toyonaka, Osaka 561-0854, Japan

© Panasonic Connect Co., Ltd. 2013

Printed in Japan

OM1303030EAE01