

Control Commands

Model No. **PT-DZ780 series**
PT-DW750 series
PT-DX820 series



パナソニック株式会社 ビジュアルシステム事業部

目次

1. LAN 経由の制御コマンドについて.....	12
2. SERIAL IN 端子経由の制御コマンドについて.....	15
3. 基本制御コマンド.....	17
3.1. POWER ON (LAMP ON) [PON]	17
3.2. POWER OFF (STANDBY) [POF]	17
3.3. FREEZE [OFZ]	17
3.4. AUTO SETUP [OAS]	17
3.5. SHUTTER [OSH]	18
3.6. INPUT SELECT [IIS].....	18
3.7. INPUT SELECT [IIS] (DIGITAL LINK).....	18
3.8. TEST PATTERN [OTS].....	19
3.9. ON-SCREEN DISPLAY [OOS]	19
3.10. MENU KEY [OMN].....	19
3.11. ENTER KEY [OEN].....	19
3.12. UP KEY (▲) [OCU].....	20
3.13. DOWN KEY (▼) [OCD]	20
3.14. LEFT KEY (◀) [OCL]	20
3.15. RIGHT KEY (▶) [OCR]	20
3.16. STANDARD (DEFAULT) KEY [OST]	20
3.17. FUNCTION KEY [FC1]	21
3.18. SYSTEM SELECTOR KEY [OSL]	21
3.19. ASPECT KEY [VS1]	21
3.20. NUMBER KEY [ONK]	21
3.21. STATUS KEY [STS]	21
3.22. LENS FOCUS KEY [OLF].....	22
3.23. LENS SHIFT KEY [OLH]	22
3.24. LENS ZOOM KEY [OLZ]	22
3.25. DIGITAL LINK KEY [DLK].....	22
3.26. PROJECTOR ID - ALL [RVS]	22
3.27. SIGNAL LIST REGISTERING [OEM]	23
3.28. SIGNAL LIST DELETING [ODM].....	23
3.29. SUB MEMORY CHANGE [OCS]	23
3.30. SUB MEMORY CHANGE (Extended) [OCS].....	23
3.31. SUB MEMORY REGISTERING [OES].....	24
3.32. SUB MEMORY DELETING [ODS].....	24
3.33. PICTURE MODE [VPM]	25
3.34. Ye MODULATE [VXX:YEMIO].....	25
3.35. DYNAMIC RGB BOOSTER [VXX: DRB1].....	25
3.36. CONTRAST [VCN]	26
3.37. BRIGHTNESS [VBR].....	26
3.38. COLOR [VCO]	26
3.39. TINT [VTN].....	27
3.40. COLOR TEMPERATURE [OTE].....	27
3.41. WHITE BALANCE LOW - RED [VOR].....	27
3.42. WHITE BALANCE LOW - GREEN [VOG]	28
3.43. WHITE BALANCE LOW - BLUE [VOB]	28
3.44. WHITE BALANCE HIGH - RED [VHR].....	28
3.45. WHITE BALANCE HIGH - GREEN [VHG].....	29
3.46. WHITE BALANCE HIGH - BLUE [VHB]	29

3.47.	NAME SETTING - COLOR TEMPERATURE USER1 [VXX:NCGS1]	29
3.48.	NAME SETTING - COLOR TEMPERATURE USER2 [VXX:NCGS3]	30
3.49.	WHITE GAIN [VWH]	30
3.50.	GAMMA MODE [VGA]	30
3.51.	SYSTEM DAYLIGHT VIEW [VXX:DLV10]	31
3.52.	SHARPNESS [VSR]	31
3.53.	NOISE REDUCTION [VNS]	31
3.54.	AI [OAI]	32
3.55.	SYSTEM SELECTOR (VIDEO / Y/C) [VSG]	32
3.56.	SYSTEM SELECTOR (RGB/DVI-D/HDMI/DIGITAL LINK) [ORF]	32
3.57.	SYSTEM SELECTOR (SDI) [VSD]	33
3.58.	SHIFT - HORIZONTAL [VTH]	33
3.59.	SHIFT - VERTICAL [VTV]	34
3.60.	ASPECT [VSE]	34
3.61.	ZOOM - HORIZONTAL [OZH]	35
3.62.	ZOOM - VERTICAL [OZV]	35
3.63.	ZOOM - HORIZONTAL / VERTICAL [OZO]	35
3.64.	ZOOM - INTERLOCKED [OZS]	36
3.65.	ZOOM - MODE [OZT]	36
3.66.	CLOCK PHASE [VCP]	36
3.67.	GEOMETRY [VXX:GMM10]	37
3.68.	GEOMETRY : KEYSTONE - LENS THROW RATIO [VXX:GMKS0]	37
3.69.	GEOMETRY : KEYSTONE - VERTICAL BALANCE [VXX:GMK14]	38
3.70.	GEOMETRY : KEYSTONE - HORIZONTAL BALANCE [VXX:GMK17]	38
3.71.	GEOMETRY : KEYSTONE - VERTICAL KEYSTONE [VXX:GMKS8]	38
3.72.	GEOMETRY : KEYSTONE - HORIZONTAL KEYSTONE [VXX:GMKS9]	39
3.73.	GEOMETRY : CURVED - LENS THROW RATIO [VXX:GMCS0]	39
3.74.	GEOMETRY : CURVED - VERTICAL ARC [VXX:GMCI3]	40
3.75.	GEOMETRY : CURVED - HORIZONTAL ARC [VXX:GMCI7]	40
3.76.	GEOMETRY : CURVED - VERTICAL BALANCE [VXX:GMCI2]	41
3.77.	GEOMETRY : CURVED - HORIZONTAL BALANCE [VXX:GMCI6]	41
3.78.	GEOMETRY : CURVED - VERTICAL KEYSTONE [VXX:GMCS8]	41
3.79.	GEOMETRY : CURVED - HORIZONTAL KEYSTONE [VXX:GMCS9]	42
3.80.	GEOMETRY : CURVED - MAINTAIN ASPECT RATIO [VXX:GMCI A]	42
3.81.	GEOMETRY : CORNER CORRECTION - UPPER LEFT - VERTICAL [VXX:GMFI1]	43
3.82.	GEOMETRY : CORNER CORRECTION - UPPER RIGHT - VERTICAL [VXX:GMFI2]	43
3.83.	GEOMETRY : CORNER CORRECTION - LOWER LEFT - VERTICAL [VXX:GMFI3]	43
3.84.	GEOMETRY : CORNER CORRECTION - LOWER RIGHT - VERTICAL [VXX:GMFI4]	44
3.85.	GEOMETRY : CORNER CORRECTION - LINEARITY - VERTICAL [VXX:GMFI5]	44
3.86.	GEOMETRY : CORNER CORRECTION - UPPER LEFT - HORIZONTAL [VXX:GMFI6]	44
3.87.	GEOMETRY : CORNER CORRECTION - UPPER RIGHT - HORIZONTAL [VXX:GMFI7]	45
3.88.	GEOMETRY : CORNER CORRECTION - LOWER LEFT - HORIZONTAL [VXX:GMFI8]	45
3.89.	GEOMETRY : CORNER CORRECTION - LOWER RIGHT - HORIZONTAL [VXX:GMFI9]	45
3.90.	GEOMETRY : CORNER CORRECTION - LINEARITY - HORIZONTAL [VXX:GMFIA]	46
3.91.	DIGITAL CINEMA REALITY [OPD]	46
3.92.	BLANKING - UPPER [DBU]	46
3.93.	BLANKING - LOWER [DBB]	47
3.94.	BLANKING - RIGHT [DBR]	47
3.95.	BLANKING - LEFT [DBL]	48
3.96.	MASKING MODE [VXX:MSK11]	48
3.97.	INPUT RESOLUTION - TOTAL DOTS [VTD]	49
3.98.	INPUT RESOLUTION - DISPLAY DOTS [VDD]	49
3.99.	INPUT RESOLUTION - TOTAL LINES [VTL]	49
3.100.	INPUT RESOLUTION - DISPLAY LINES [VDL]	50
3.101.	CLAMP POSITION [VLT]	50

3.102.	EDGE BLENDING [VXX:EDBI0].....	50
3.103.	EDGE BLENDING - UPPER ON/OFF [VGU]	51
3.104.	EDGE BLENDING - LOWER ON/OFF [VGB].....	51
3.105.	EDGE BLENDING - LEFT ON/OFF [VGL]	51
3.106.	EDGE BLENDING - RIGHT ON/OFF [VGR]	51
3.107.	EDGE BLENDING - START - UPPER [VEU].....	52
3.108.	EDGE BLENDING - START - LOWER [VEB]	52
3.109.	EDGE BLENDING - START - LEFT [VEL].....	52
3.110.	EDGE BLENDING - START - RIGHT [VER].....	53
3.111.	EDGE BLENDING - WIDTH - UPPER [VXX:EUWI0]	53
3.112.	EDGE BLENDING - WIDTH - LOWER [VXX:EBWI0]	53
3.113.	EDGE BLENDING - WIDTH - LEFT [VXX:ELWI0].....	54
3.114.	EDGE BLENDING - WIDTH - RIGHT [VXX:ERWI0]	54
3.115.	EDGE BLENDING - MARKER ON/OFF [VGM].....	54
3.116.	EDGE BLENDING - NON-OVERLAPPED BLACK LEVEL [VJI]	55
3.117.	EDGE BLENDING - NON-OVERLAPPED BLACK LEVEL - INTERLOCKED [VXX:EBII1].....	55
3.118.	EDGE BLENDING - BLACK BORDER LEVEL [VJO].....	55
3.119.	EDGE BLENDING - BLACK BORDER LEVEL - INTERLOCKED [VXX:EBII2].....	56
3.120.	EDGE BLENDING - BLACK BORDER WIDTH - UPPER [VJU].....	56
3.121.	EDGE BLENDING - BLACK BORDER WIDTH - LOWER [VJB]	57
3.122.	EDGE BLENDING - BLACK BORDER WIDTH - LEFT [VJL].....	57
3.123.	EDGE BLENDING - BLACK BORDER WIDTH - RIGHT [VJR].....	57
3.124.	EDGE BLENDING - BLACK BORDER WIDTH - UPPER KEYSTONE AREA [VXX:EBBI4]	58
3.125.	EDGE BLENDING - BLACK BORDER WIDTH - LOWER KEYSTONE AREA [VXX:EBBI5]	58
3.126.	EDGE BLENDING - BLACK BORDER WIDTH - LEFT KEYSTONE AREA [VXX:EBBI6].....	58
3.127.	EDGE BLENDING - BLACK BORDER WIDTH - RIGHT KEYSTONE AREA [VXX:EBBI7]	59
3.128.	EDGE BLENDING - OVERLAPPED BLACK LEVEL - UPPER [VXX:EBBS0]	59
3.129.	EDGE BLENDING - OVERLAPPED BLACK LEVEL - LOWER [VXX:EBBS1].....	60
3.130.	EDGE BLENDING - OVERLAPPED BLACK LEVEL - LEFT [VXX:EBBS2]	60
3.131.	EDGE BLENDING - OVERLAPPED BLACK LEVEL - RIGHT [VXX:EBBS3].....	61
3.132.	EDGE BLENDING - OVERLAPPED BLACK LEVEL - UPPER INTERLOCKED [VXX:EBII3].....	61
3.133.	EDGE BLENDING - OVERLAPPED BLACK LEVEL - LOWER INTERLOCKED [VXX:EBII4].....	62
3.134.	EDGE BLENDING - OVERLAPPED BLACK LEVEL - LEFT INTERLOCKED [VXX:EBII5]	62
3.135.	EDGE BLENDING - OVERLAPPED BLACK LEVEL - RIGHT INTERLOCKED [VXX:EBII6].....	62
3.136.	FRAME RESPONSE [VXX:FDYI0].....	63
3.137.	RASTER POSITION - HORIZONTAL [VRH]	63
3.138.	RASTER POSITION - VERTICAL [VRV]	63
3.139.	DISPLAY LANGUAGE [OLG]	64
3.140.	COLOR MATCHING [VXX:CMAI0].....	64
3.141.	COLOR CORRECTION [VCM].....	64
3.142.	COLOR CORRECTION - RED [VXX:CCRI0]	65
3.143.	COLOR CORRECTION - GREEN [VXX:CCRI1].....	65
3.144.	COLOR CORRECTION - BLUE [VXX:CCRI2]	65
3.145.	COLOR CORRECTION - CYAN [VXX:CCRI3].....	66
3.146.	COLOR CORRECTION - MAGENTA [VXX:CCRI4]	66
3.147.	COLOR CORRECTION - YELLOW [VXX:CCRI5].....	66
3.148.	SCREEN SETTING - SCREEN FORMAT [VSF]	67
3.149.	SCREEN SETTING - SCREEN POSITION - VERTICAL [VXX:VSPI0].....	67
3.150.	SCREEN SETTING - SCREEN POSITION - HORIZONTAL [VXX:HSPI0]	68
3.151.	AUTO SIGNAL [VXX:AASI0]	68
3.152.	AUTO SETUP - MODE [OAM].....	68
3.153.	AUTO SETUP - POSITION [VXX:APAI0]	69
3.154.	AUTO SETUP - SIGNAL LEVEL [VXX:ASLI0].....	69
3.155.	BACKUP INPUT SETTING - BACKUP INPUT [VXX:BACI1]	69
3.156.	BACKUP INPUT SETTING - BACKUP INPUT MODE [VXX:BACI2].....	70

3.157. BACKUP INPUT SETTING - AUTOMATIC SWITCHING [VXX:BACI3].....	70
3.158. RGB IN - RGB1 INPUT SETTING [VXX:RYCI1]	70
3.159. RGB IN - RGB1 SYNC SLICE LEVEL [VXX:STRI0].....	71
3.160. RGB IN - RGB2 SYNC SLICE LEVEL [VXX:STRI1].....	71
3.161. RGB IN - RGB2 EDID MODE [VXX:EDMI1].....	71
3.162. RGB IN - RGB2 EDID RESOLUTION [VXX:EDRS1]	72
3.163. RGB IN - RGB2 EDID VERTICAL SCAN FREQUENCY [VXX: EDVI1]	73
3.164. DVI-D IN - EDID [OED].....	73
3.165. DVI-D IN - SIGNAL LEVEL [VXX:DVII0].....	73
3.166. DVI-D IN - EDID MODE [VXX:EDMI2].....	74
3.167. DVI-D IN - EDID RESOLUTION [VXX: EDRS2].....	74
3.168. DVI-D IN - EDID VERTICAL SCAN FREQUENCY [VXX: EDVI2]	75
3.169. HDMI IN - SIGNAL LEVEL [VXX:HSLI0]	75
3.170. HDMI IN - EDID MODE [VXX:EDMI3]	76
3.171. HDMI IN - EDID RESOLUTION [VXX: EDRS3].....	76
3.172. HDMI IN - EDID VERTICAL SCAN FREQUENCY [VXX: EDVI3].....	77
3.173. DIGITAL LINK IN - SIGNAL LEVEL [VXX:DKLI1]	77
3.174. DIGITAL LINK IN - EDID MODE [VXX:EDMI4].....	78
3.175. DIGITAL LINK IN - EDID RESOLUTION [VXX: EDRS4]	78
3.176. DIGITAL LINK IN - EDID VERTICAL SCAN FREQUENCY [VXX: EDVI4]	79
3.177. SDI IN - SIGNAL LEVEL [OED].....	79
3.178. SDI IN - SDI SIGNAL LEVEL [VXX:SSL11].....	80
3.179. SDI IN - BIT DEPTH [VXX:SBT11]	80
3.180. SDI IN - 3G-SDI MAPPING [VXX:SGMI1].....	80
3.181. ON-SCREEN DISPLAY - OSD POSITION [ODP]	81
3.182. ON-SCREEN DISPLAY - OSD DESIGN [MOD]	81
3.183. ON-SCREEN DISPLAY - OSD MEMORY [VXX:OMYI0].....	81
3.184. ON-SCREEN DISPLAY - INPUT GUIDE [OID].....	82
3.185. ON-SCREEN DISPLAY - WARNING MESSAGE [VXX:WMDI0]	82
3.186. CLOSED CAPTION SETTING [OCC]	82
3.187. BACK COLOR [OBC]	82
3.188. STARTUP LOGO [MLO]	83
3.189. UNIFORMITY - PC CORRECTION [VXX: UFMI1]	83
3.190. SHUTTER SETTING - FADE IN [VXX:SEFS1]	83
3.191. SHUTTER SETTING - FADE OUT [VXX:SEFS2]	84
3.192. SHUTTER SETTING - STARTUP [VXX:SEFI3]	84
3.193. SHUTTER SETTING - SHUT OFF [VXX:SEFI4].....	84
3.194. WAVEFORM MONITOR [OWM].....	85
3.195. WAVEFORM MONITOR - ADJUST [VXX:WMLI0].....	85
3.196. CUT OFF - RED [VXX:CUTI1].....	85
3.197. CUT OFF - GREEN [VXX:CUTI2].....	86
3.198. CUT OFF - BLUE [VXX:CUTI3]	86
3.199. P IN P [OPP].....	86
3.200. P IN P - MAIN WINDOW [MSI]	87
3.201. P IN P - MAIN WINDOW SIZE - INTERLOCKED [MSL]	87
3.202. P IN P - MAIN WINDOW SIZE - VERTICAL [MSV]	87
3.203. P IN P - MAIN WINDOW SIZE - HORIZONTAL [MSH].....	88
3.204. P IN P - MAIN WINDOW SIZE - BOTH [MSZ].....	88
3.205. P IN P - MAIN WINDOW POSITION - VERTICAL [MPV].....	88
3.206. P IN P - MAIN WINDOW POSITION - HORIZONTAL [MPH]	89
3.207. P IN P - SUB WINDOW [SIS]	89
3.208. P IN P - SUB WINDOW SIZE - INTERLOCKED [SSL].....	89
3.209. P IN P - SUB WINDOW SIZE - VERTICAL [SSV]	90
3.210. P IN P - SUB WINDOW SIZE - HORIZONTAL [SSH].....	90
3.211. P IN P - SUB WINDOW SIZE - BOTH [SSZ].....	90

3.212.	P IN P - SUB WINDOW POSITION - VERTICAL [SPV]	91
3.213.	P IN P - SUB WINDOW POSITION - HORIZONTAL [SPH]	91
3.214.	P IN P - SUB WINDOW - CLOCK PHASE [VXX:SCPIO]	91
3.215.	P IN P - FRAME LOCK [PFL]	92
3.216.	P IN P - TYPE [PTP]	92
3.217.	PROJECTOR ID [RIS]	92
3.218.	PROJECTION METHOD [OIL]	92
3.219.	COOLING CONDITION [ODR]	93
3.220.	HIGH ALTITUDE MODE [OFM]	93
3.221.	LAMP SELECT [LPM]	93
3.222.	LAMP RELAY [VXX:LRYI0]	93
3.223.	LAMP RELAY WEEK [VXX:LRYI2]	94
3.224.	LAMP POWER [VXX:LPWI1]	94
3.225.	BRIGHTNESS CONTROL - GAIN [VXX:TGAI0]	95
3.226.	BRIGHTNESS CONTROL - MODE [VXX:BCMI0]	95
3.227.	BRIGHTNESS CONTROL - LINK [VXX:BCLI0]	95
3.228.	BRIGHTNESS CONTROL - CALIBRATION TIME [VXX:BTMI1]	96
3.229.	BRIGHTNESS CONTROL - CALIBRATION MESSAGE [VXX:BMGI1]	96
3.230.	BRIGHTNESS CONTROL - START [VXX:BCSI0]	96
3.231.	STANDBY MODE [VXX:STMI0]	97
3.232.	SCHEDULE [VXX:SCHI0]	97
3.233.	SCHEDULE - PROGRAM ASSIGN [VXX:SPGI]	97
3.234.	SCHEDULE - SET COMMAND [VXX:SCCS]	98
3.235.	INITIAL STARTUP [OPY]	99
3.236.	STARTUP INPUT SELECT [VXX:SISS1]	99
3.237.	STARTUP INPUT SELECT (DIGITAL LINK) [VXX:SISI2]	99
3.238.	NO SIGNAL SHUT - OFF [OAF]	100
3.239.	FUNCTION [OFC]	100
3.240.	DATE AND TIME - ADJUST CLOCK DATE [TSD]	100
3.241.	DATE AND TIME - ADJUST CLOCK TIME [TST]	101
3.242.	DATE AND TIME - NTP SYNCHRONIZATION [VXX:NTPI0]	101
3.243.	LENS CALIBRATION [VXX:LNSI0]	101
3.244.	LENS HOME POSITION [VXX:LNSI1]	102
3.245.	LENS SHIFT - HORIZONTAL [VXX:LNSI2]	102
3.246.	LENS SHIFT - VERTICAL [VXX:LNSI3]	103
3.247.	LENS FOUCS [VXX:LNSI4]	103
3.248.	LENS ZOOM [VXX:LNSI5]	103
3.249.	LENS TYPE [VXX:LNSI6]	104
3.250.	INITIALIZE - ALL USER DATA [VXX:RSTS1]	104
3.251.	NETWORK SETUP - PROJECTOR NAME [VXX:NCGS8]	105
3.252.	DIGITAL LINK MODE [VXX:DKMI1]	105
3.253.	DIGITAL LINK SETUP - DUPLEX (ETHERNET) [VXX:DKDI1]	105
3.254.	DIGITAL LINK SETUP - DUPLEX (DIGITAL LINK) [VXX:DKDI2]	106
3.255.	Art-Net SETUP [VXX:DANI1]	106
3.256.	Art-Net SETUP - START ADDRESS [VXX:DANI3]	106
3.257.	Art-Net SETUP - NET [VXX:DANI4]	107
3.258.	Art-Net SETUP - SUB NET [VXX:DANI5]	107
3.259.	Art-Net SETUP - UNIVERSE [VXX:DANI6]	107
3.260.	Art-Net SETUP - CHANNEL SETUP [VXX:DANI8]	108
3.261.	COLOR WHEEL INDEX [VXX:CWII0]	108
3.262.	QUERY POWER [QPW]	109
3.263.	QUERY FREEZE [QFZ]	109
3.264.	QUERY SHUTTER [QSH]	109
3.265.	QUERY INPUT SELECT [QIN]	109
3.266.	QUERY TEST PATTERN [QTS]	110

3.267. QUERY ON-SCREEN DISPLAY [QOS].....	110
3.268. QUERY PROJECTOR ID - ALL [QVY]	110
3.269. QUERY SUB MEMORY USAGE STATE [QSB]	111
3.270. QUERY PICTURE MODE [QPM]	111
3.271. QUERY Ye MODULATE [QVX:YEMIO].....	111
3.272. QUERY DYNAMIC RGB BOOSTER [QVX:DRBI1].....	112
3.273. QUERY COLOR [QVC].....	112
3.274. QUERY TINT [QVT].....	112
3.275. QUERY CONTRAST [QVR].....	113
3.276. QUERY BRIGHTNESS [QVB].....	113
3.277. QUERY COLOR TEMPERATURE [QTE].....	113
3.278. QUERY WHITE BALANCE LOW - RED [QOR].....	114
3.279. QUERY WHITE BALANCE LOW - GREEN [QOG]	114
3.280. QUERY WHITE BALANCE LOW - BLUE [QOB].....	114
3.281. QUERY WHITE BALANCE HIGH - RED [QHR].....	114
3.282. QUERY WHITE BALANCE HIGH - GREEN [QHG].....	115
3.283. QUERY WHITE BALANCE HIGH - BULE [QHB]	115
3.284. QUERY NAME - COLOR TEMPERATURE USER1 [QVX:NCGS1].....	115
3.285. QUERY NAME - COLOR TEMPERATURE USER2 [QVX:NCGS3].....	116
3.286. QUERY WHITE GAIN [QWH].....	116
3.287. QUERY GAMMA [QGA].....	116
3.288. QUERY SYSTEM DAYLIGHT VIEW [QVX:DLVI0]	116
3.289. QUERY SHARPNESS [QVS]	117
3.290. QUERY NOISE REDUCTION [QNS].....	117
3.291. QUERY AI [QAI].....	117
3.292. SYSTEM SELECTOR (VIDEO / Y/C) [QSG].....	118
3.293. SYSTEM SELECTOR (RGB/DVI-D/HDMI/DIGITAL LINK) [QRF]	118
3.294. SYSTEM SELECTOR (SDI) [QSD]	118
3.295. QUERY SHIFT - HORIZONTAL [QTH]	119
3.296. QUERY SHIFT - VERTICAL [QTV].....	119
3.297. QUERY ASPECT [QSE]	119
3.298. QUERY ZOOM - HORIZONTAL [QZH].....	120
3.299. QUERY ZOOM - VERTICAL [QZV]	120
3.300. QUERY ZOOM HORIZONTAL / VERTICAL [QZO]	120
3.301. QUERY ZOOM INTERLOCKED [QZS]	120
3.302. QUERY ZOOM MODE [QZT]	121
3.303. QUERY CLOCK PHASE [QCP].....	121
3.304. QUERY GEOMETRY [QVX:GMMIO]	121
3.305. QUERY GEOMETRY : KEYSTONE - LENS THROW RATIO [QVX:GMKS0].....	122
3.306. QUERY GEOMETRY : KEYSTONE - VERTICAL BALANCE [QVX:GMKI4].....	122
3.307. QUERY GEOMETRY : KEYSTONE - HORIZONTAL BALANCE [QVX:GMKI7].....	122
3.308. QUERY GEOMETRY : KEYSTONE - VERTICAL KEYSTONE [QVX:GMKS8].....	123
3.309. QUERY GEOMETRY : KEYSTONE - HORIZONTAL KEYSTONE [QVX:GMKS9]	123
3.310. QUERY GEOMETRY : CURVED - LENS THROW RATIO [QVX:GMCS0]	124
3.311. QUERY GEOMETRY : CURVED - VERTICAL ARC [QVX:GMCI3].....	124
3.312. QUERY GEOMETRY : CURVED - HORIZONTAL ARC [QVX:GMCI7]	124
3.313. QUERY GEOMETRY : CURVED - VERTICAL BALANCE [QVX:GMCI2]	125
3.314. QUERY GEOMETRY : CURVED - HORIZONTAL BALANCE [QVX:GMCI6].....	125
3.315. QUERY GEOMETRY : CURVED - VERTICAL KEYSTONE [QVX:GMCS8].....	125
3.316. QUERY GEOMETRY : CURVED - VERTICAL KEYSTONE [QVX:GMCS9]	126
3.317. QUERY GEOMETRY : CURVED - MAINTAIN ASPECT RATIO [QVX:GMCIA]	126
3.318. QUERY GEOMETRY : CORNER CORRECTION - UPPER LEFT - VERTICAL [QVX:GMFI1]	127
3.319. QUERY GEOMETRY : CORNER CORRECTION - UPPER RIGHT - VERTICAL [QVX:GMFI2].....	127
3.320. QUERY GEOMETRY : CORNER CORRECTION - LOWER LEFT - VERTICAL [QVX:GMFI3].....	127
3.321. QUERY GEOMETRY : CORNER CORRECTION - LOWER RIGHT - VERTICAL [QVX:GMFI4]	128

3.322. QUERY GEOMETRY : CORNER CORRECTION - LINEARITY - VERTICAL [QVX:GMFI5].....	128
3.323. QUERY GEOMETRY : CORNER CORRECTION - UPPER LEFT - HORIZONTAL [QVX:GMFI6].....	128
3.324. QUERY GEOMETRY : CORNER CORRECTION - UPPER RIGHT - HORIZONTAL [QVX:GMFI7].....	129
3.325. QUERY GEOMETRY : CORNER CORRECTION - LOWER LEFT - HORIZONTAL [QVX:GMFI8].....	129
3.326. QUERY GEOMETRY : CORNER CORRECTION - LOWER RIGHT - HORIZONTAL [QVX:GMFI9].....	129
3.327. QUERY GEOMETRY : CORNER CORRECTION - LINEARITY - HORIZONTAL [QVX:GMFIA].....	130
3.328. QUERY DIGITAL CINEMA REALITY [QPD].....	130
3.329. QUERY BLANKING - UPPER [QLU].....	130
3.330. QUERY BLANKING - LOWER [QLB].....	131
3.331. QUERY BLANKING - RIGHT [QLR].....	131
3.332. QUERY BLANKING - LEFT [QLL].....	131
3.333. QUERY CUSTOM MASKING [QVX:MSK1].....	132
3.334. QUERY INPUT RESOLUTION - TOTAL DOTS [QTD].....	132
3.335. QUERY INPUT RESOLUTION - DISPLAY DOTS [QDD].....	133
3.336. QUERY INPUT RESOLUTION - TOTAL LINES [QTL].....	133
3.337. QUERY INPUT RESOLUTION - DISPLAY LINES [QDL].....	133
3.338. QUERY CLAMP POSITION [QLT].....	134
3.339. QUERY EDGE BLENDING [QVX:EDBI0].....	134
3.340. QUERY EDGE BLENDING - UPPER ON/OFF [QGU].....	134
3.341. QUERY EDGE BLENDING - LOWER ON/OFF [QGB].....	134
3.342. QUERY EDGE BLENDING - LEFT ON/OFF [QGL].....	135
3.343. QUERY EDGE BLENDING - RIGHT ON/OFF [QGR].....	135
3.344. QUERY EDGE BLENDING - START - UPPER [QEU].....	135
3.345. QUERY EDGE BLENDING - START - LOWER [QEB].....	135
3.346. QUERY EDGE BLENDING - START - LEFT [QEL].....	136
3.347. QUERY EDGE BLENDING - START - RIGHT [QER].....	136
3.348. QUERY EDGE BLENDING - WIDTH - UPPER [QVX:EUWI0].....	136
3.349. QUERY EDGE BLENDING - WIDTH - LOWER [QVX:EBWI0].....	136
3.350. QUERY EDGE BLENDING - WIDTH - LEFT [QVX:ELWI0].....	137
3.351. QUERY EDGE BLENDING - WIDTH - RIGHT [QVX:ERWI0].....	137
3.352. QUERY EDGE BLENDING - MARKER ON/OFF [QGM].....	137
3.353. QUERY EDGE BLENDING - NON-OVERLAPPED BLACK LEVEL [QJI].....	137
3.354. QUERY EDGE BLENDING - NON-OVERLAPPED BLACK LEVEL - INTERLOCKED [QVX:EBI1].....	138
3.355. QUERY EDGE BLENDING - BLACK BORDER LEVEL [QJO].....	138
3.356. QUERY EDGE BLENDING - BLACK BORDER LEVEL - INTERLOCKED [QVX:EBI2].....	139
3.357. QUERY EDGE BLENDING - BLACK BORDER WIDTH - UPPER [QJU].....	139
3.358. QUERY EDGE BLENDING - BLACK BORDER WIDTH - LOWER [QJB].....	139
3.359. QUERY EDGE BLENDING - BLACK BORDER WIDTH - LEFT [QJL].....	139
3.360. QUERY EDGE BLENDING - BLACK BORDER WIDTH - RIGHT [QJR].....	140
3.361. QUERY EDGE BLENDING - BLACK BORDER WIDTH - UPPER KEYSTONE AREA [QVX:EBBI4].....	140
3.362. QUERY EDGE BLENDING - BLACK BORDER WIDTH - LOWER KEYSTONE AREA [QVX:EBBI5].....	140
3.363. QUERY EDGE BLENDING - BLACK BORDER WIDTH - LEFT KEYSTONE AREA [QVX:EBBI6].....	140
3.364. QUERY EDGE BLENDING - BLACK BORDER WIDTH - RIGHT KEYSTONE AREA [QVX:EBBI7].....	141
3.365. QUERY EDGE BLENDING - OVERLAPPED BLACK LEVEL - UPPER [QVX:EBBS0].....	141
3.366. QUERY EDGE BLENDING - OVERLAPPED BLACK LEVEL - LOWER [QVX:EBBS1].....	141
3.367. QUERY EDGE BLENDING - OVERLAPPED BLACK LEVEL - LEFT [QVX:EBBS2].....	142
3.368. QUERY EDGE BLENDING - OVERLAPPED BLACK LEVEL - RIGHT [QVX:EBBS3].....	142
3.369. QUERY EDGE BLENDING - OVERLAPPED BLACK LEVEL - UPPER INTERLOCKED [QVX:EBI3].....	143
3.370. QUERY EDGE BLENDING - OVERLAPPED BLACK LEVEL - LOWER INTERLOCKED [QVX:EBI4].....	143
3.371. QUERY EDGE BLENDING - OVERLAPPED BLACK LEVEL - LEFT INTERLOCKED [QVX:EBI5].....	143
3.372. QUERY EDGE BLENDING - OVERLAPPED BLACK LEVEL - RIGHT INTERLOCKED [QVX:EBI6].....	144
3.373. QUERY FRAME RESPONSE [QVX:FDYI0].....	144
3.374. QUERY RASTER POSITION - HORIZONTAL [QRH].....	144
3.375. QUERY RASTER POSITION - VERTICAL [QRV].....	145
3.376. QUERY DISPLAY LANGUAGE [QLG].....	145

3.377. QUERY COLOR MATCHING [QVX:CMAI0].....	145
3.378. QUERY COLOR CORRECTION [QMC].....	146
3.379. QUERY COLOR CORRECTION - RED [QVX:CCRI0].....	146
3.380. QUERY COLOR CORRECTION - GREEN [QVX:CCRI1].....	146
3.381. QUERY COLOR CORRECTION - BLUE [QVX:CCRI2].....	147
3.382. QUERY COLOR CORRECTION - CYAN [QVX:CCRI3].....	147
3.383. QUERY COLOR CORRECTION - MAGENTA [QVX:CCRI4].....	147
3.384. QUERY COLOR CORRECTION - YELLOW [QVX:CCRI5].....	148
3.385. QUERY SCREEN SETTING - SCREEN FORMAT [QSF].....	148
3.386. QUERY SCREEN SETTING - SCREEN POSITION - VERTICAL [QVX:VSP10].....	148
3.387. QUERY SCREEN SETTING - SCREEN POSITION - HORIZONTAL [QVX:HSP10].....	149
3.388. QUERY AUTO SIGNAL [QVX:AASI0].....	149
3.389. QUERY AUTO SETUP - MODE [QAM].....	149
3.390. QUERY AUTO SETUP - POSITION [QVX:APAI0].....	150
3.391. QUERY AUTO SETUP - SIGNAL LEVEL [QVX:ASLI0].....	150
3.392. QUERY BACKUP INPUT SETTING – BACKUP INPUT MODE [QVX:BACI2].....	150
3.393. QUERY BACKUP INPUT SETTING – AUTOMATIC SWITCHING [QVX:BACI3].....	151
3.394. QUERY BACKUP INPUT SETTING – BACKUP INPUT STATUS [QVX:BACI4].....	151
3.395. QUERY RGB IN - RGB1 INPUT SETTING [QVX:RYCI1].....	151
3.396. QUERY RGB IN - RGB1 SYNC SLICE LEVEL [QVX:STRI0].....	152
3.397. QUERY RGB IN - RGB2 SYNC SLICE LEVEL [QVX:STRI1].....	152
3.398. QUERY RGB IN - RGB2 EDID MODE [QVX:EDMI1].....	152
3.399. QUERY RGB IN - RGB2 EDID RESOLUTION [QVX:EDRS1].....	153
3.400. QUERY RGB IN - RGB2 EDID VERTICAL SCAN FREQUENCY [QVX:EDVI1].....	153
3.401. QUERY DVI-D IN - EDID [QED].....	154
3.402. QUERY DVI-D IN - SIGNAL LEVEL [QVX:DVII0].....	154
3.403. QUERY DVI-D IN - EDID MODE [QVX:EDMI2].....	154
3.404. QUERY DVI-D IN - EDID RESOLUTION [QVX:EDRS2].....	155
3.405. QUERY DVI-D IN - EDID VERTICAL SCAN FREQUENCY [QVX:EDVI2].....	156
3.406. QUERY HDMI IN - SIGNAL LEVEL [QVX:HSLI0].....	156
3.407. QUERY HDMI IN - EDID MODE [QVX:EDMI3].....	156
3.408. QUERY HDMI IN - EDID RESOLUTION [QVX:EDRS3].....	157
3.409. QUERY HDMI IN - EDID VERTICAL SCAN FREQUENCY [QVX:EDVI3].....	157
3.410. QUERY DIGITAL LINK - SIGNAL LEVEL [QVX:DKLI1].....	158
3.411. QUERY DIGITAL LINK - EDID MODE [QVX:EDMI4].....	158
3.412. QUERY DIGITAL LINK - EDID RESOLUTION [QVX:EDRS4].....	158
3.413. QUERY DIGITAL LINK - EDID VERTICAL SCAN FREQUENCY [QVX:EDVI4].....	159
3.414. QUERY SDI IN – SDI LEVEL [QED:SDI-LEVEL].....	160
3.415. QUERY SDI IN – SDI SIGNAL LEVEL [QVX:SSL1].....	160
3.416. QUERY SDI IN - BIT DEPTH [QVX:SBT1].....	160
3.417. QUERY SDI IN - 3G-SDI MAPPING [QVX:SGMI1].....	161
3.418. QUERY ON-SCREEN DISPLAY - OSD POSITION [QDP].....	161
3.419. QUERY ON-SCREEN DISPLAY - OSD DESIGN [QOD].....	161
3.420. QUERY ON-SCREEN DISPLAY - OSD MEMORY [QVX:OMY10].....	161
3.421. QUERY ON-SCREEN DISPLAY - INPUT GUIDE [QDI].....	162
3.422. QUERY ON-SCREEN DISPLAY - WARNING MESSAGE [QVX:WMDI0].....	162
3.423. CLOSED CAPTION SETTING [QCC].....	162
3.424. QUERY BACK COLOR [QBC].....	162
3.425. QUERY STARTUP LOGO [QLO].....	163
3.426. QUERY UNIFORMITY - PC CORRECTION [QVX:UFMI1].....	163
3.427. QUERY SHUTTER SETTING - FADE IN [QVX:SEFS1].....	163
3.428. QUERY SHUTTER SETTING - FADE OUT [QVX:SEFS2].....	164
3.429. QUERY SHUTTER SETTING - STARTUP [QVX:SEFI3].....	164
3.430. QUERY SHUTTER SETTING - SHUT OFF [QVX:SEFI4].....	164
3.431. QUERY WAVEFORM MONITOR [QWM].....	165

3.432.	QUERY WAVEFORM MONITOR - ADJUST LEVEL [QVX:WMLI0]	165
3.433.	QUERY CUT OFF - RED [QVX:CUT11]	165
3.434.	QUERY CUT OFF - GREEN [QVX:CUTI2]	165
3.435.	QUERY CUT OFF - BLUE [QVX:CUTI3]	166
3.436.	QUERY PROJECTION METHOD [QSP]	166
3.437.	QUERY COOLING CONDITION [QDR]	166
3.438.	QUERY AUTO COOLING CONDITION - STATUS [QVX:ADRI1]	166
3.439.	QUERY RUNTIME - PROJECTOR [QST]	167
3.440.	QUERY LAMP SELECT [QSL]	167
3.441.	QUERY LAMP RELAY [QVX:LRYI0]	167
3.442.	QUERY LAMP RELAY - WEEK [QVX:LRYI2]	168
3.443.	QUERY LAMP POWER [QVX:LPWI1]	168
3.444.	QUERY BRIGHTNESS CONTROL - GAIN [QVX:TGA10]	168
3.445.	QUERY BRIGHTNESS CONTROL - MODE [QVX:BCMI0]	169
3.446.	QUERY BRIGHTNESS CONTROL - LINK [QVX:BCLI0]	169
3.447.	QUERY BRIGHTNESS CONTROL - CALIBRATION TIME [QVX:BTMI1]	169
3.448.	QUERY BRIGHTNESS CONTROL - CALIBRATION MESSAGE [QVX:BMGI1]	170
3.449.	QUERY STANDBY MODE [QVX:STMI0]	170
3.450.	QUERY SCHEDULE [QVX:SCHI0]	170
3.451.	QUERY SCHEDULE - PROGRAM ASSIGN [QVX:SPGI]	171
3.452.	QUERY SCHEDULE - COMMAND SETTING [QVX:SCCS]	171
3.453.	QUERY INITIAL STARTUP [QPY]	172
3.454.	QUERY STARTUP INPUT SELECT [QVX:SISS1]	172
3.455.	QUERY STARTUP INPUT SELECT (DIGITAL LINK) [QVX:SISS2]	172
3.456.	QUERY NO SIGNAL SHUT-OFF [QAF]	173
3.457.	QUERY FUNCTION BUTTON SETTING [QFC]	173
3.458.	QUERY DATE AND TIME - DATE [QGD]	173
3.459.	QUERY DATE AND TIME - TIME [QGT]	173
3.460.	QUERY DATE AND TIME - NTP SYNCHRONIZATION [QVX:NTPI0]	174
3.461.	QUERY P IN P [QPP]	174
3.462.	QUERY P IN P - MAIN WINDOW [QIM]	174
3.463.	QUERY P IN P - MAIN WINDOW - SIZE [QSM]	174
3.464.	QUERY P IN P - MAIN WINDOW - POSITION [QPA]	175
3.465.	QUERY P IN P - SUB WINDOW [QIS]	176
3.466.	QUERY P IN P - SUB WINDOW - SIZE [QSS]	176
3.467.	QUERY P IN P - SUB WINDOW - POSITION [QPS]	177
3.468.	QUERY P IN P - SUB WINDOW - CLOCK PHASE [QVX:SCPI0]	177
3.469.	QUERY P IN P - FRAME LOCK [QPF]	177
3.470.	QUERY P IN P - TYPE [QPT]	178
3.471.	QUERY - SECURITY PASSWORD SETTING [QVX:SPWI1]	178
3.472.	QUERY NAME - PROJECTOR NAME [QVX:NCGS8]	178
3.473.	QUERY NAME - SIGNAL NAME (MAIN INPUT) [QVX:NSGS1]	179
3.474.	QUERY NAME - SIGNAL NAME (SUB INPUT) [QVX:NSGS2]	179
3.475.	QUERY DIGITAL LINK MODE [QVX:DKMI1]	179
3.476.	QUERY DIGITAL LINK SETUP - DUPLEX (ETHERNET) [QVX:DKDI1]	180
3.477.	QUERY DIGITAL LINK SETUP - DUPLEX (DIGITAL LINK) [QVX:DKDI2]	180
3.478.	QUERY DIGITAL LINK STATUS - LINK STATUS [QVX:DKSI1]	180
3.479.	QUERY DIGITAL LINK STATUS - HDCP STATUS [QVX:DKSI2]	181
3.480.	QUERY DIGITAL LINK STATUS - SIGNAL QUALITY (MIN) [QVX:DKSI3]	181
3.481.	QUERY DIGITAL LINK STATUS - SIGNAL QUALITY (MAX) [QVX:DKSI4]	181
3.482.	QUERY DIGITAL LINK INPUT CHANNEL LIST [QVX:DL1S1]	182
3.483.	QUERY Art-Net SETUP [QVX:DANI1]	182
3.484.	QUERY Art-Net SETUP - START ADDRESS [QVX:DANI3]	182
3.485.	QUERY Art-Net SETUP - NET [QVX:DANI4]	183
3.486.	QUERY Art-Net SETUP - SUB NET [QVX:DANI5]	183

3.487.	QUERY Art-Net SETUP - UNIVERSE [QVX:DANI6]	183
3.488.	QUERY Art-Net SETUP - CHANNEL SETUP [QVX:DANI8].....	184
3.489.	QUERY COLOR WHEEL INDEX [QVX:CWII0]	184
3.490.	QUERY PROJECTOR SERIAL NUMBER [QSN].....	184
3.491.	QUERY SELF CHECK [QVX:STS1].....	185
3.492.	QUERY LAMP UNIT MODEL No. [QVX:LMNS0].....	185
3.493.	QUERY LAMP UNIT 1 SERIAL No. [QVX:LSNS0].....	185
3.494.	QUERY LAMP UNIT 2 SERIAL No. [QVX:LSNS1].....	186
3.495.	QUERY RUNTIME - LAMP1 [Q\$L:1].....	186
3.496.	QUERY RUNTIME - LAMP2 [Q\$L:2].....	186
3.497.	QUERY LAMP CONTROL STATUS [Q\$\$].....	187
3.498.	QUERY LAMP STATUS [QLS].....	187
3.499.	QUERY LENS TYPE [QVX:LNSI6].....	187
3.500.	QUERY AIR FILTER TYPE [QFI:2].....	187
3.501.	QUERY TEMPERATURE [QTM]	188
3.502.	QUERY FAN DRIVE VOLTAGE [QVX:FNVI].....	188
3.503.	QUERY PROJECTOR TYPE [QID]	188
3.504.	QUERY SOFTWARE VERSION - MAIN MICROPROCESSOR [QVX:SVRS0]	189
3.505.	QUERY SOFTWARE VERSION - SUB MICROPROCESSOR [QVX:SVRS2].....	189
4.	拡張制御コマンド	190
4.1.	LENS CONTROL.....	190
4.2.	SELF CHECK INFORMATION	191

1. LAN 経由の制御コマンドについて

接続

■ 通常のネットワーク接続例

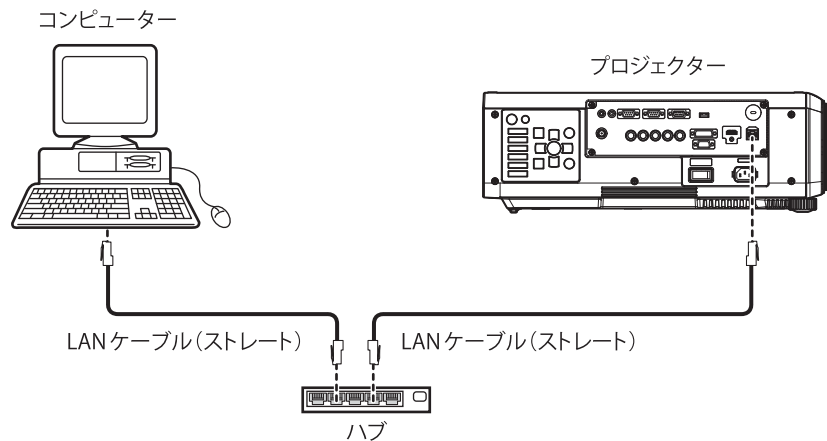

■ ツイストペアケーブル伝送器経由のネットワーク接続例

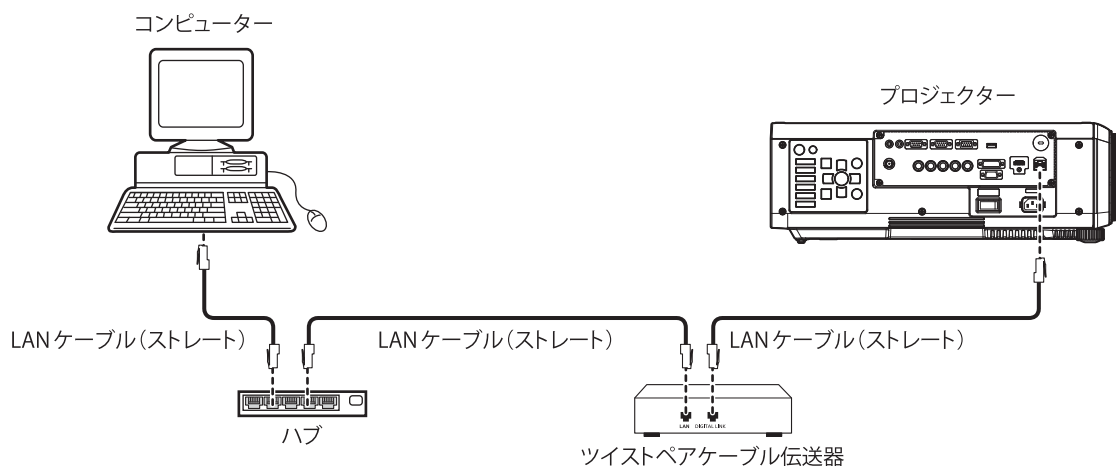

- LAN ケーブルはカテゴリ 5 以上対応のものをご使用ください。
- LAN ケーブル長は 100 m 以下のものをご使用ください。

WEB 制御アドミニストレーター権限パスワード設定時 (プロテクトモード)

接続方法

- 1) プロジェクターの IP アドレスとポート番号 (初期設定値 = 1024) を取得してプロジェクターへ接続を要求する
 - IP アドレス、ポート番号は共にプロジェクター本体のメニュー画面から取得できます。

IP アドレス	メニューの [ネットワーク] → [ネットワークステータス] から取得
ポート番号	メニューの [ネットワーク] → [ネットワークコントロール] → [コマンドポート] から取得

2) プロジェクターからの応答を確認する

	データ部	空白	モード	空白	乱数部	終端記号
コマンド例	"NTCONTROL" (ASCII 文字列)	' '	'1'	' '	"zzzzzzzz" (ASCII コード 16 進数)	(CR) 0x0d
データ長	9 bytes	1 byte	1 byte	1 byte	8 bytes	1 byte

- モード：1= プロテクトモード
- 例) プロテクトモード時の応答 (乱数部は不定値)
"NTCONTROL 1 23181e1e" (CR)

3) MD5 アルゴリズムを用いて以下のデータから 32 バイトのハッシュ値を生成する

- "xxxxxx:yyyyy:zzzzzzz"

xxxxxx	WEB 制御のアドミニストレーター権限ユーザー名 (デフォルトのユーザー名は "admin1")
yyyyy	上記アドミニストレーター権限ユーザーのパスワード (デフォルトのパスワードは "panasonic")
zzzzzzz	手順 2) で取得した 8 バイトの乱数

コマンド送信方法

以下のコマンド形式で送信してください。

■ 送信データ

	ヘッダー			データ部	終端記号
コマンド例	ハッシュ値 (上記 "接続方法" 参照)	'0' 0x30	'0' 0x30	制御コマンド (ASCII 文字列)	(CR) 0x0d
データ長	32 bytes	1 byte	1 byte	不定長	1 byte

- 例) 電源状態取得コマンドの送信 (ハッシュ値はデフォルトのユーザー名、パスワードおよび取得した乱数より算出)
"dbdd2dabd3d4d68c5dd970ec0c29fa6400QPW" (CR)

■ 受信データ

	ヘッダー		データ部	終端記号
コマンド例	'0' 0x30	'0' 0x30	制御コマンド (ASCII 文字列)	(CR) 0x0d
データ長	1 byte	1 byte	不定長	1 byte

- 例) プロジェクターの電源が入っている場合
"00001" (CR)

■ エラー応答

	文字列	内容	終端記号
メッセージ	"ERR1"	未定義の制御コマンド	(CR) 0x0d
	"ERR2"	パラメーター範囲外	
	"ERR3"	ビジー状態または受け付け不可期間	
	"ERR4"	タイムアウトまたは受け付け不可期間	
	"ERR5"	データ長不正	
	"ERRA"	パスワード不一致	
データ長	4 bytes	—	1 byte

WEB 制御アドミニストレータ権限パスワード非設定時（非プロテクトモード）

接続方法

- 1) プロジェクターの IP アドレスとポート番号（初期設定値 =1024）を取得してプロジェクターへ接続を要求する

- IP アドレス、ポート番号は共にプロジェクター本体のメニュー画面から取得できます。

IP アドレス	メニューの [ネットワーク] → [ネットワークステータス] から取得
ポート番号	メニューの [ネットワーク] → [ネットワークコントロール] → [コマンドポート] から取得

- 2) プロジェクターからの応答を確認する

	データ部	空白	モード	終端記号
コマンド例	"NTCONTROL" (ASCII 文字列)	' '	'0'	(CR)
		0x20	0x30	0x0d
データ長	9 bytes	1 byte	1 byte	1 byte

- モード：0= 非プロテクトモード
- 例) 非プロテクトモード時の応答
"NTCONTROL 0" (CR)

コマンド送信方法

以下のコマンド形式で送信してください。

■ 送信データ

	ヘッダー		データ部	終端記号
コマンド例	'0'	'0'	制御コマンド (ASCII 文字列)	(CR)
	0x30	0x30		0x0d
データ長	1 byte	1 byte	不定長	1 byte

- 例) 電源状態取得コマンドの送信
"OOQPW" (CR)

■ 受信データ

	ヘッダー		データ部	終端記号
コマンド例	'0'	'0'	制御コマンド (ASCII 文字列)	(CR)
	0x30	0x30		0x0d
データ長	1 byte	1 byte	不定長	1 byte

- 例) プロジェクターの電源がスタンバイ状態の場合
"OOOOO" (CR)

■ エラー応答

	文字列	内容	終端記号
メッセージ	"ERR1"	未定義の制御コマンド	(CR) 0x0d
	"ERR2"	パラメーター範囲外	
	"ERR3"	ビジー状態または受け付け不可期間	
	"ERR4"	タイムアウトまたは受け付け不可期間	
	"ERR5"	データ長不正	
	"ERRA"	パスワード不一致	
データ長	4 bytes	—	1 byte

2. SERIAL IN 端子経由の制御コマンドについて

接続

1台の場合

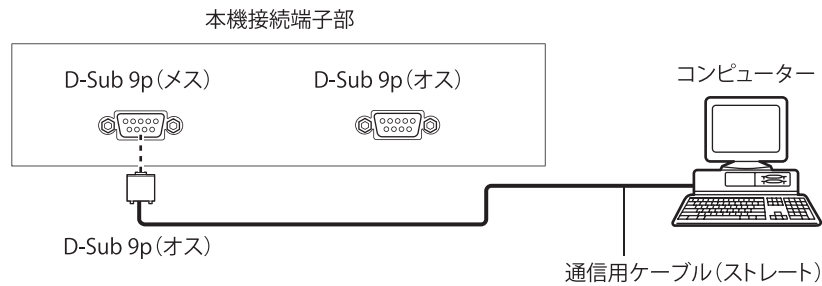

複数台の場合

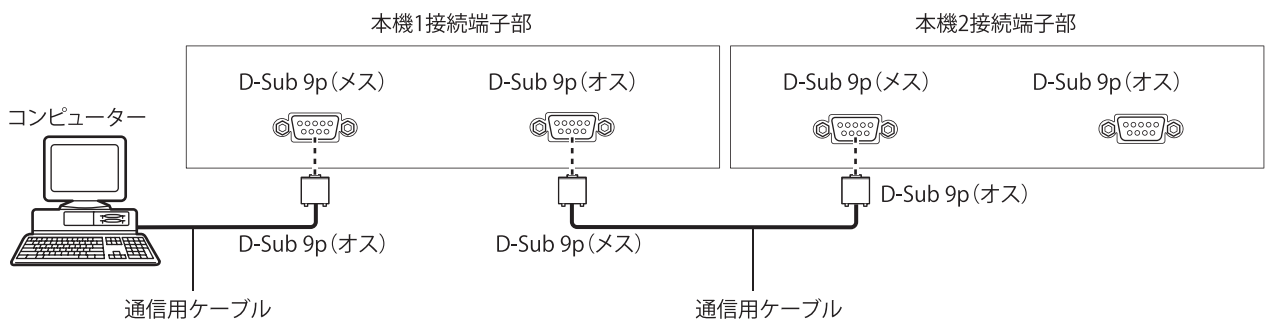

DIGITAL LINK 対応機器を利用して接続する場合

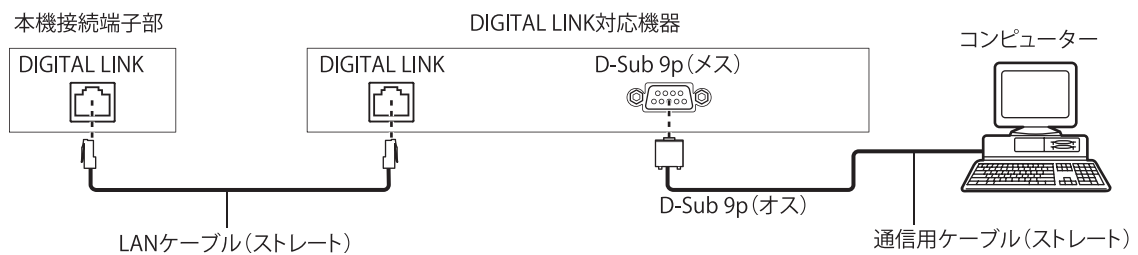

お知らせ

- 接続方法に合わせて、[RS-232C] の接続先を設定する必要があります。
- DIGITAL LINK 対応機器を利用して接続する場合、スタンバイ状態で本機を制御するには、メニューの[プロジェクターセットアップ] → [スタンバイモード] の設定を [ノーマル] に設定してください。
[スタンバイモード] を [ECO] に設定しているときは、スタンバイ状態での本機の制御はできません。

ピン配列と信号名

D-Sub 9ピン (メス) 外側から見た図	ピン No.	信号名	内容	D-Sub 9ピン (オス) 外側から見た図	ピン No.	信号名	内容
	(1)	—	NC		(1)	—	NC
	(2)	TXD	送信データ		(2)	RXD	受信データ
	(3)	RXD	受信データ		(3)	TXD	送信データ
	(4)	—	NC		(4)	—	NC
	(5)	GND	グラウンド		(5)	GND	グラウンド
	(6)	—	NC		(6)	—	NC
	(7)	CTS	内部で接続されています		(7)	RTS	内部で接続されています
	(8)	RTS			(8)	CTS	
	(9)	—	NC		(9)	—	NC

通信条件（工場出荷時の状態）

信号レベル	RS -232C 準拠
同期方式	調歩同期
ボーレート	9 600 bps
パリティ	なし
キャラクター長	8ビット
ストップビット	1ビット
Xパラメーター	なし
Sパラメーター	なし

基本フォーマット

コンピューターからの伝送は STX で開始され、続いて ID、コマンド、パラメーター、最後に ETX の順に送信します。パラメーターは制御内容の必要に応じて付加してください。

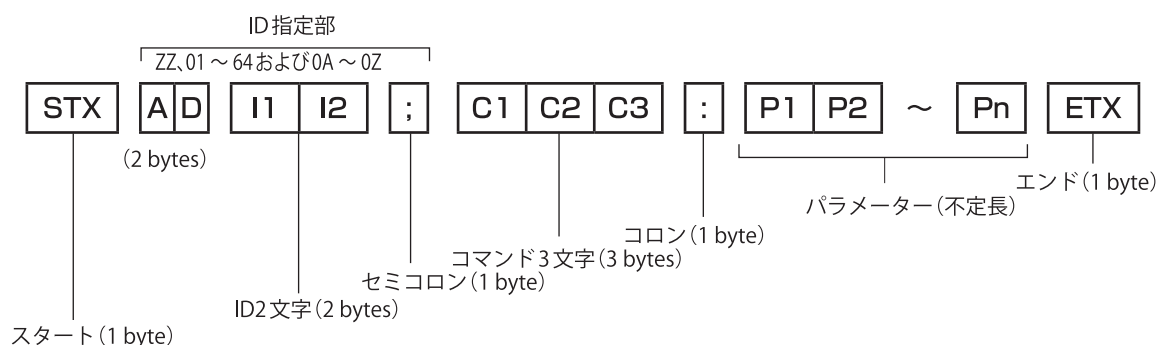

基本フォーマット（サブコマンドあり）

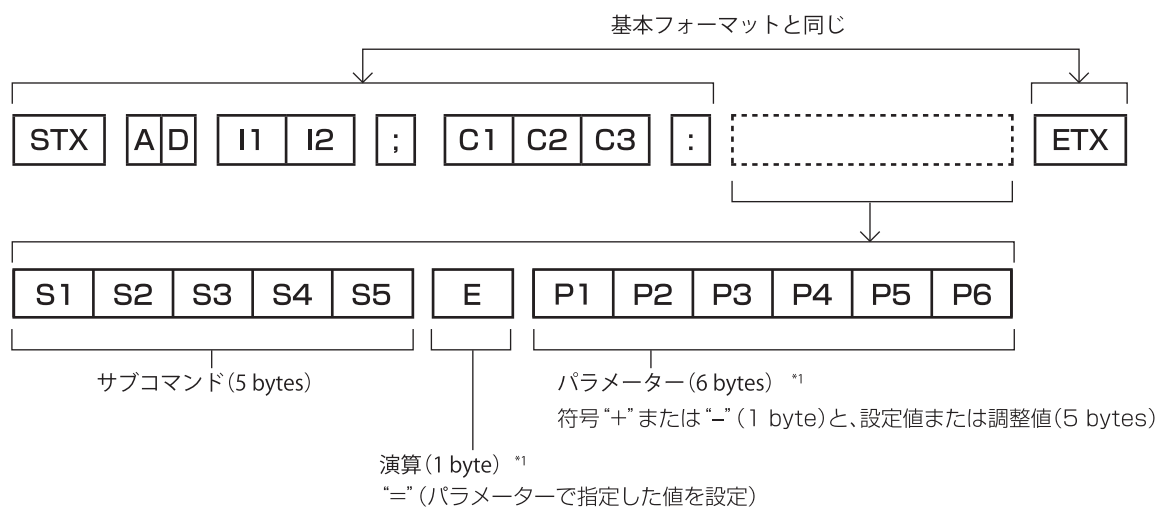

*1 パラメーターを必要としないコマンドを送信する場合は、演算 (E) とパラメーターは必要ありません。

お願い

- ランプの点灯開始直後にコマンドを送信すると、応答が遅く返ってきたり、コマンドが実行できなかつたりすることがあります。60 秒経過後に送受信してください。
- 複数のコマンドを送信する場合は、必ず本機からの応答を受け取ってから 0.5 秒以上経過後に次のコマンドを送信してください。パラメーターを必要としないコマンドを送信する場合は、コロン (:) は必要ありません。

お知らせ

- コマンドが実行できない場合、本機から「ER401」という応答がコンピューター側に送信されます。
- 無効なパラメーターを送信すると、本機から「ER402」という応答がコンピューター側に送信されます。
- RS -232C での ID 送信は、ZZ (オール) と 01 ~ 64 および 0A ~ 0Z のグループの対応になっています。
- ID 指定でコマンドを送信した場合、以下のときのみコンピューターへの応答を返します。
 - 本機 ID と一致した場合
 - ID 指定がオールかつ [応答 (ID オール)] が [オン] の場合
 - ID 指定がグループかつ [応答 (ID グループ)] が [オン] の場合
- STX と ETX はキャラクターコードです。STX は 16 進数で表すと 02、ETX は 16 進数で表すと 03 となります。

3. 基本制御コマンド

3.1. POWER ON (LAMP ON) [PON]

Hexadecimal	02h	41h	44h	5Ah	5Ah	3Bh	50h	4Fh	4Eh	03h
Character		A	D	Z	Z	;	P	O	N	

■ Response (Callback)

In the period when the command can be accepted (This command in power-on condition is included)

Hexadecimal	02h	50h	4Fh	4Eh	03h
Character		P	O	N	

Acceptability

SECURITY	STANDBY	ECO STANDBY	NO SIGNAL	SHUTTER	FREEZE	TEST PATTERN	REMOTE2	P IN P	LENS HOME
✓	✓	✓	✓	✓	✓	✓	✓ *	✓	

■ Note:

- When you confirm whether to have succeeded in power-on, confirm it by QPW (Query Power) command after receiving the callback of PON command.
- REMOTE2 is given to priority. Calls back ER401 when the parameter is different from the setting of REMOTE2.

3.2. POWER OFF (STANDBY) [POF]

Hexadecimal	02h	41h	44h	5Ah	5Ah	3Bh	50h	4Fh	46h	03h
Character		A	D	Z	Z	;	P	O	F	

■ Response (Callback)

In the period when the command can be accepted (This command in power-on condition is included)

Hexadecimal	02h	50h	4Fh	46h	03h
Character		P	O	F	

Acceptability

SECURITY	STANDBY	ECO STANDBY	NO SIGNAL	SHUTTER	FREEZE	TEST PATTERN	REMOTE2	P IN P	LENS HOME
✓	✓	✓	✓	✓	✓	✓	✓ *	✓	

■ Note:

- When you confirm whether to have succeeded in power-off, confirm it by QPW (Query Power) command after receiving the callback of POF command.
- REMOTE2 is given to priority. Calls back ER401 when the parameter is different from the setting of REMOTE2.

3.3. FREEZE [OFZ]

Hexadecimal	02h	41h	44h	5Ah	5Ah	3Bh	4Fh	46h	5Ah	3Ah	*1	03h
Character		A	D	Z	Z	;	O	F	Z	:	*2	

■ Parameters (*1,*2)

	FREEZE OFF	FREEZE ON
Hexadecimal	30h	31h
Character	0	1

■ Response (Callback)

In the period when the command can be accepted

Hexadecimal	02h	4Fh	46h	5Ah	3Ah	*1	03h
Character		O	F	Z	:	*2	

Acceptability

SECURITY	STANDBY	ECO STANDBY	NO SIGNAL	SHUTTER	FREEZE	TEST PATTERN	REMOTE2	P IN P	LENS HOME
					✓	✓	✓	✓	

3.4. AUTO SETUP [OAS]

Hexadecimal	02h	41h	44h	5Ah	5Ah	3Bh	4Fh	41h	53h	03h
Character		A	D	Z	Z	;	O	A	S	

■ Response (Callback)

In the period when the command can be accepted

Hexadecimal	02h	4Fh	41h	53h	03h
Character		O	A	S	

Acceptability

SECURITY	STANDBY	ECO STANDBY	NO SIGNAL	SHUTTER	FREEZE	TEST PATTERN	REMOTE2	P IN P	LENS HOME
				✓	✓		✓	✓	

■ Note:

- If the signal of non-compliant, returns the ER401.

3.5. SHUTTER [OSH]

Hexadecimal	02h	41h	44h	5Ah	5Ah	3Bh	4Fh	53h	48h	3Ah	*1	03h
Character		A	D	Z	Z	;	O	S	H	:	*2	

■ Parameters (*1,*2)

	SHUTTER OFF	SHUTTER ON
Hexadecimal	30h	31h
Character	0	1

■ Response (Callback)

In the period when the command can be accepted

Hexadecimal	02h	4Fh	53h	48h	3Ah	*1	03h
Character		O	S	H	:	*2	

Acceptability

SECURITY	STANDBY	ECO STANDBY	NO SIGNAL	SHUTTER	FREEZE	TEST PATTERN	REMOTE2	P IN P	LENS HOME
✓	✓		✓	✓	✓	✓	✓*	✓	

■ Note:

· REMOTE2 is given to priority. Calls back ER402 when the parameter is different from the setting of REMOTE2.

3.6. INPUT SELECT [IIS]

Hexadecimal	02h	41h	44h	5Ah	5Ah	3Bh	49h	49h	53h	3Ah
Character		A	D	Z	Z	;	I	I	S	:
Hexadecimal	*1	*3	*5	03h						
Character	*2	*4	*6							

■ Parameters (*1,*2,*3,*4,*5,*6)

	RGB1			RGB2			VIDEO		
Hexadecimal	52h	47h	31h	52h	47h	32h	56h	49h	44h
Character	R	G	1	R	G	2	V	I	D
	DVI			HDMI			SDI		
Hexadecimal	44h	56h	49h	48h	44h	31h	53h	44h	31h
Character	D	V	I	H	D	1	S	D	1
	DIGITAL LINK								
Hexadecimal	44h	4Ch	31h						
Character	D	L	1						

■ Response (Callback)

In the period when the command can be accepted

Hexadecimal	02h	49h	49h	53h	3Ah	*1	*3	*5	03h
Character		I	I	S	:	*2	*4	*6	

Acceptability

SECURITY	STANDBY	ECO STANDBY	NO SIGNAL	SHUTTER	FREEZE	TEST PATTERN	REMOTE2	P IN P	LENS HOME
	✓		✓	✓	✓	✓	✓*	✓	

■ Note:

· REMOTE2 is given to priority. Calls back ER402 if the input select of REMOTE2 is available.
 · Parameter SDI is only effective for DZ780(FDZ88C).

3.7. INPUT SELECT [IIS] (DIGITAL LINK)

Hexadecimal	02h	41h	44h	5Ah	5Ah	3Bh	49h	49h	53h	3Ah
Character		A	D	Z	Z	;	I	I	S	:
Hexadecimal	44h	4Ch	31h	3Ah	*1	*3	*5	03h		
Character	D	L	1	:	*2	*4	*6			

■ Parameters (*1,*2,*3,*4,*5,*6)

	HDMI1			HDMI2			COMPUTER1		
Hexadecimal	48h	44h	31h	48h	44h	32h	50h	43h	31h
Character	H	D	1	H	D	2	P	C	1
	COMPUTER2			S-VIDEO			VIDEO		
Hexadecimal	50h	43h	32h	53h	56h	44h	56h	49h	44h
Character	P	C	2	S	V	D	V	I	D

■ Response (Callback)

In the period when the command can be accepted

Hexadecimal	02h	49h	49h	53h	3Ah	44h	4Ch	31h	3Ah
Character		I	I	S	:	D	L	1	:
Hexadecimal	*1	*3	*5	03h					
Character	*2	*4	*6						

Acceptability

SECURITY	STANDBY	ECO STANDBY	NO SIGNAL	SHUTTER	FREEZE	TEST PATTERN	REMOTE2	P IN P	LENS HOME
	✓		✓	✓	✓	✓	✓*	✓	

■ Note:

· REMOTE2 is given to priority. Calls back ER402 if the input select of REMOTE2 is available.
 · Only when connecting the digital interface box, it is effective.

3.8. TEST PATTERN [OTS]

Hexadecimal	02h	41h	44h	5Ah	5Ah	3Bh	4Fh	54h	53h	3Ah
Character		A	D	Z	Z	;	O	T	S	:
Hexadecimal	*1	*3	03h							
Character	*2	*4								

■ Parameters (*1,*2,*3,*4)

	OFF		White		Black		Flag		Reversed Flag	
Hexadecimal	30h	30h	30h	31h	30h	32h	30h	33h	30h	34h
Character	0	0	0	1	0	2	0	3	0	4
	Window		Reversed Window		Focus (White)		Color bar (vertical)		Convergence	
Hexadecimal	30h	35h	30h	36h	31h	31h	30h	38h	31h	31h
Character	0	5	0	6	1	1	0	8	1	1
	Red		Green		Blue		Cyan		Magenta	
Hexadecimal	32h	32h	32h	33h	32h	34h	32h	38h	32h	39h
Character	2	2	2	3	2	4	2	8	2	9
	Yellow		CW INDEX		Color bar (horizontal)		16:9/4:3		Lamp (vertical)	
Hexadecimal	33h	30h	34h	31h	35h	31h	35h	39h	36h	37h
Character	3	0	4	1	5	1	5	9	6	7
	Focus (Green)		Focus (Blue)		Focus (Cyan)		Focus (Magenta)		Focus (Yellow)	
Hexadecimal	37h	31h	37h	32h	37h	33h	37h	34h	37h	35h
Character	7	1	7	2	7	3	7	4	7	5

■ Response (Callback)

In the period when the command can be accepted

Hexadecimal	02h	4Fh	54h	53h	3Ah	*1	*3	03h
Character		O	T	S	:	*2	*4	

Acceptability

SECURITY	STANDBY	ECO STANDBY	NO SIGNAL	SHUTTER	FREEZE	TEST PATTERN	REMOTE2	P IN P	LENS HOME
			✓	✓		✓	✓	✓	

3.9. ON-SCREEN DISPLAY [OOS]

Hexadecimal	02h	41h	44h	5Ah	5Ah	3Bh	4Fh	4Fh	53h	3Ah	*1	03h
Character		A	D	Z	Z	;	O	O	S	:	*2	

■ Parameters (*1,*2)

	OSD OFF			OSD ON		
Hexadecimal	30h			31h		
Character	0			1		

■ Response (Callback)

In the period when the command can be accepted

Hexadecimal	02h	4Fh	4Fh	53h	3Ah	*1	03h
Character		O	O	S	:	*2	

Acceptability

SECURITY	STANDBY	ECO STANDBY	NO SIGNAL	SHUTTER	FREEZE	TEST PATTERN	REMOTE2	P IN P	LENS HOME
			✓	✓	✓	✓	✓	✓	

■ Note:

· If the logo is being displayed is invalid.

3.10. MENU KEY [OMN]

Hexadecimal	02h	41h	44h	5Ah	5Ah	3Bh	4Fh	4Dh	4Eh	03h
Character		A	D	Z	Z	;	O	M	N	

■ Response (Callback)

In the period when the command can be accepted

Hexadecimal	02h	4Fh	4Dh	4Eh	03h
Character		O	M	N	

Acceptability

SECURITY	STANDBY	ECO STANDBY	NO SIGNAL	SHUTTER	FREEZE	TEST PATTERN	REMOTE2	P IN P	LENS HOME
✓			✓	✓	✓	✓	✓	✓	✓

3.11. ENTER KEY [OEN]

Hexadecimal	02h	41h	44h	5Ah	5Ah	3Bh	4Fh	45h	4Eh	03h
Character		A	D	Z	Z	;	O	E	N	

■ Response (Callback)

In the period when the command can be accepted

Hexadecimal	02h	4Fh	45h	4Eh	03h
Character		O	E	N	

Acceptability

SECURITY	STANDBY	ECO STANDBY	NO SIGNAL	SHUTTER	FREEZE	TEST PATTERN	REMOTE2	P IN P	LENS HOME
✓	✓		✓	✓	✓	✓	✓	✓	

3.12. UP KEY (▲) [OCU]

Hexadecimal	02h	41h	44h	5Ah	5Ah	3Bh	4Fh	43h	55h	03h
Character		A	D	Z	Z	;	O	C	U	

■ Response (Callback)

In the period when the command can be accepted

Hexadecimal	02h	4Fh	43h	55h	03h
Character		O	C	U	

Acceptability

SECURITY	STANDBY	ECO STANDBY	NO SIGNAL	SHUTTER	FREEZE	TEST PATTERN	REMOTE2	P IN P	LENS HOME
✓			✓	✓	✓	✓	✓	✓	

3.13. DOWN KEY (▼) [OCD]

Hexadecimal	02h	41h	44h	5Ah	5Ah	3Bh	4Fh	43h	44h	03h
Character		A	D	Z	Z	;	O	C	D	

■ Response (Callback)

In the period when the command can be accepted

Hexadecimal	02h	4Fh	43h	44h	03h
Character		O	C	D	

Acceptability

SECURITY	STANDBY	ECO STANDBY	NO SIGNAL	SHUTTER	FREEZE	TEST PATTERN	REMOTE2	P IN P	LENS HOME
✓			✓	✓	✓	✓	✓	✓	

3.14. LEFT KEY (◀) [OCL]

Hexadecimal	02h	41h	44h	5Ah	5Ah	3Bh	4Fh	43h	4Ch	03h
Character		A	D	Z	Z	;	O	C	L	

■ Response (Callback)

In the period when the command can be accepted

Hexadecimal	02h	4Fh	43h	4Ch	03h
Character		O	C	L	

Acceptability

SECURITY	STANDBY	ECO STANDBY	NO SIGNAL	SHUTTER	FREEZE	TEST PATTERN	REMOTE2	P IN P	LENS HOME
✓			✓	✓	✓	✓	✓	✓	

3.15. RIGHT KEY (▶) [OCR]

Hexadecimal	02h	41h	44h	5Ah	5Ah	3Bh	4Fh	43h	52h	03h
Character		A	D	Z	Z	;	O	C	R	

■ Response (Callback)

In the period when the command can be accepted

Hexadecimal	02h	4Fh	43h	52h	03h
Character		O	C	R	

Acceptability

SECURITY	STANDBY	ECO STANDBY	NO SIGNAL	SHUTTER	FREEZE	TEST PATTERN	REMOTE2	P IN P	LENS HOME
✓			✓	✓	✓	✓	✓	✓	

3.16. STANDARD (DEFAULT) KEY [OST]

Hexadecimal	02h	41h	44h	5Ah	5Ah	3Bh	4Fh	53h	54h	03h
Character		A	D	Z	Z	;	O	S	T	

■ Response (Callback)

In the period when the command can be accepted

Hexadecimal	02h	4Fh	53h	54h	03h
Character		O	S	T	

Acceptability

SECURITY	STANDBY	ECO STANDBY	NO SIGNAL	SHUTTER	FREEZE	TEST PATTERN	REMOTE2	P IN P	LENS HOME
			✓	✓	✓	✓	✓	✓	

3.17. FUNCTION KEY [FC1]

Hexadecimal	02h	41h	44h	5Ah	5Ah	3Bh	46h	43h	31h	03h
Character		A	D	Z	Z	;	F	C	1	

■ Response (Callback)

In the period when the command can be accepted

Hexadecimal	02h	46h	43h	31h	03h
Character		F	C	1	

Acceptability

SECURITY	STANDBY	ECO STANDBY	NO SIGNAL	SHUTTER	FREEZE	TEST PATTERN	REMOTE2	P IN P	LENS HOME
			✓ *		✓	✓	✓	✓	

■ Note:

· Acceptability is applied corresponding to the function assigned in the FUNCTION key.

3.18. SYSTEM SELECTOR KEY [OSL]

Hexadecimal	02h	41h	44h	5Ah	5Ah	3Bh	4Fh	53h	4Ch	03h
Character		A	D	Z	Z	;	O	S	L	

■ Response (Callback)

In the period when the command can be accepted

Hexadecimal	02h	4Fh	53h	4Ch	03h
Character		O	S	L	

Acceptability

SECURITY	STANDBY	ECO STANDBY	NO SIGNAL	SHUTTER	FREEZE	TEST PATTERN	REMOTE2	P IN P	LENS HOME
			✓	✓	✓	✓	✓	✓	

3.19. ASPECT KEY [VS1]

Hexadecimal	02h	41h	44h	5Ah	5Ah	3Bh	56h	53h	31h	03h
Character		A	D	Z	Z	;	V	S	1	

■ Response (Callback)

In the period when the command can be accepted

Hexadecimal	02h	56h	53h	31h	03h
Character		V	S	1	

Acceptability

SECURITY	STANDBY	ECO STANDBY	NO SIGNAL	SHUTTER	FREEZE	TEST PATTERN	REMOTE2	P IN P	LENS HOME
			✓	✓	✓	✓	✓	✓	

3.20. NUMBER KEY [ONK]

Hexadecimal	02h	41h	44h	5Ah	5Ah	3Bh	4Fh	4Eh	4Bh	3Ah	*1	03h
Character		A	D	Z	Z	;	O	N	K	:	*2	

■ Parameters (*1,*2)

	0 KEY	1 KEY	2 KEY	3 KEY	4 KEY	5 KEY	6 KEY	7 KEY	8 KEY	9 KEY
Hexadecimal	30h	31h	32h	33h	34h	35h	36h	37h	38h	39h
Character	0	1	2	3	4	5	6	7	8	9

■ Response (Callback)

In the period when the command can be accepted

Hexadecimal	02h	4Fh	4Eh	4Bh	3Ah	*1	03h
Character		O	N	K	:	*2	

Acceptability

SECURITY	STANDBY	ECO STANDBY	NO SIGNAL	SHUTTER	FREEZE	TEST PATTERN	REMOTE2	P IN P	LENS HOME
✓			✓	✓	✓	✓	✓	✓	

3.21. STATUS KEY [STS]

Hexadecimal	02h	41h	44h	5Ah	5Ah	3Bh	53h	54h	53h	03h
Character		A	D	Z	Z	;	S	T	S	

■ Response (Callback)

In the period when the command can be accepted

Hexadecimal	02h	53h	54h	53h	03h
Character		S	T	S	

Acceptability

SECURITY	STANDBY	ECO STANDBY	NO SIGNAL	SHUTTER	FREEZE	TEST PATTERN	REMOTE2	P IN P	LENS HOME
			✓		✓	✓	✓	✓	

3.22. LENS FOCUS KEY [OLF]

Hexadecimal	02h	41h	44h	5Ah	5Ah	3Bh	4Fh	4Ch	46h	03h
Character		A	D	Z	Z	;	O	L	F	

■ Response (Callback)

In the period when the command can be accepted

Hexadecimal	02h	4Fh	4Ch	46h	03h
Character		O	L	F	

Acceptability

SECURITY	STANDBY	ECO STANDBY	NO SIGNAL	SHUTTER	FREEZE	TEST PATTERN	REMOTE2	P IN P	LENS HOME
			✓		✓	✓	✓	✓	

3.23. LENS SHIFT KEY [OLH]

Hexadecimal	02h	41h	44h	5Ah	5Ah	3Bh	4Fh	4Ch	48h	03h
Character		A	D	Z	Z	;	O	L	H	

■ Response (Callback)

In the period when the command can be accepted

Hexadecimal	02h	4Fh	4Ch	48h	03h
Character		O	L	H	

Acceptability

SECURITY	STANDBY	ECO STANDBY	NO SIGNAL	SHUTTER	FREEZE	TEST PATTERN	REMOTE2	P IN P	LENS HOME
			✓		✓	✓	✓	✓	

3.24. LENS ZOOM KEY [OLZ]

Hexadecimal	02h	41h	44h	5Ah	5Ah	3Bh	4Fh	4Ch	5Ah	03h
Character		A	D	Z	Z	;	O	L	Z	

■ Response (Callback)

In the period when the command can be accepted

Hexadecimal	02h	4Fh	4Ch	5Ah	03h
Character		O	L	Z	

Acceptability

SECURITY	STANDBY	ECO STANDBY	NO SIGNAL	SHUTTER	FREEZE	TEST PATTERN	REMOTE2	P IN P	LENS HOME
			✓		✓	✓	✓	✓	

3.25. DIGITAL LINK KEY [DLK]

Hexadecimal	02h	41h	44h	5Ah	5Ah	3Bh	44h	4Ch	4Bh	03h
Character		A	D	Z	Z	;	D	L	K	

■ Response (Callback)

In the period when the command can be accepted

Hexadecimal	02h	44h	4Ch	4Bh	03h
Character		D	L	K	

Acceptability

SECURITY	STANDBY	ECO STANDBY	NO SIGNAL	SHUTTER	FREEZE	TEST PATTERN	REMOTE2	P IN P	LENS HOME
			✓		✓	✓	✓	✓	

3.26. PROJECTOR ID - ALL [RVS]

Hexadecimal	02h	41h	44h	5Ah	5Ah	3Bh	52h	56h	53h	3Ah	*1	03h
Character		A	D	Z	Z	;	R	V	S	:	*2	

Parameters (*1,*2)

	OFF	ON
Hexadecimal	30h	31h
Character	0	1

■ Response (Callback)

In the period when the command can be accepted

Hexadecimal	02h	52h	56h	53h	3Ah	*1	03h
Character		R	V	S	:	*2	

Acceptability

SECURITY	STANDBY	ECO STANDBY	NO SIGNAL	SHUTTER	FREEZE	TEST PATTERN	REMOTE2	P IN P	LENS HOME
✓	✓		✓	✓	✓	✓	✓	✓	

3.27. SIGNAL LIST REGISTERING [OEM]

Hexadecimal	02h	41h	44h	5Ah	5Ah	3Bh	4Fh	45h	4Dh	03h
Character		A	D	Z	Z	;	O	E	M	

■ Response (Callback)

In the period when the command can be accepted

Hexadecimal	02h	4Fh	45h	4Dh	03h
Character		O	E	M	

Acceptability

SECURITY	STANDBY	ECO STANDBY	NO SIGNAL	SHUTTER	FREEZE	TEST PATTERN	REMOTE2	P IN P	LENS HOME
				✓		✓	✓	✓	

3.28. SIGNAL LIST DELETING [ODM]

Hexadecimal	02h	41h	44h	5Ah	5Ah	3Bh	4Fh	44h	4Dh	3Ah
Character		A	D	Z	Z	;	O	D	M	:
Hexadecimal	*1	*3	03h							
Character	*2	*4								

■ Parameters (*1,*2,*3,*4)

	A1		A2		A7		A8	
Hexadecimal	41h	31h	41h	32h	41h	37h	41h	38h
Character	A	1	A	2	A	7	A	8
	L1		L2		L7		L8	
Hexadecimal	4Ch	31h	4Ch	32h	4Ch	37h	4Ch	38h
Character	L	1	L	2	L	7	L	8

■ Response (Callback)

In the period when the command can be accepted

Hexadecimal	02h	4Fh	44h	4Dh	3Ah	*1	*3	03h
Character		O	D	M	:	*2	*4	

Acceptability

SECURITY	STANDBY	ECO STANDBY	NO SIGNAL	SHUTTER	FREEZE	TEST PATTERN	REMOTE2	P IN P	LENS HOME
			✓	✓	✓	✓	✓	✓	

3.29. SUB MEMORY CHANGE [OCS]

Hexadecimal	02h	41h	44h	5Ah	5Ah	3Bh	4Fh	43h	53h	3Ah
Character		A	D	Z	Z	;	O	C	S	:
Hexadecimal	*1	*3	03h							
Character	*2	*4								

■ Parameters (*1,*2,*3,*4)

"nn" of the sub memory number (mm-nn)

	01		02		03		04	
Hexadecimal	30h	31h	30h	32h	30h	33h	30h	34h
Character	0	1	0	2	0	3	0	4
	93		94		95		96	
Hexadecimal	39h	33h	39h	34h	39h	35h	39h	36h
Character	9	3	9	4	9	5	9	6

■ Response (Callback)

In the period when the command can be accepted

Hexadecimal	02h	4Fh	43h	53h	3Ah	*1	*3	03h
Character		O	C	S	:	*2	*4	

Acceptability

SECURITY	STANDBY	ECO STANDBY	NO SIGNAL	SHUTTER	FREEZE	TEST PATTERN	REMOTE2	P IN P	LENS HOME
				✓		✓	✓	✓	

3.30. SUB MEMORY CHANGE (Extended) [OCS]

Hexadecimal	02h	41h	44h	5Ah	5Ah	3Bh	4Fh	43h	53h	3Ah
Character		A	D	Z	Z	;	O	C	S	:
Hexadecimal	*1	*3	2Dh	*5	*7	03h				
Character	*2	*4	-	*6	*8					

■ Parameters

"mm" of the sub memory number (mm-nn) (*1,*2,*3,*4)

	01		02		03		04	
Hexadecimal	30h	31h	30h	32h	30h	33h	30h	34h
Character	0	1	0	2	0	3	0	4
	92		93		94		95	
Hexadecimal	39h	32h	39h	33h	39h	34h	39h	35h
Character	9	2	9	3	9	4	9	5

"nn" of the sub memory number (mm-nn) (*5,*6,*7,*8)

	01		02		03		04	
Hexadecimal	30h	31h	30h	32h	30h	33h	30h	34h
Character	0	1	0	2	0	3	0	4
	93		94		95		96	
Hexadecimal	39h	33h	39h	34h	39h	35h	39h	36h
Character	9	3	9	4	9	5	9	6

■ Response (Callback)

In the period when the command can be accepted

Hexadecimal	02h	4Fh	43h	53h	3Ah	*1	*3	2Dh
Character		O	C	S	:	*2	*4	-
Hexadecimal	*5	*7	03h					
Character	*6	*8						

Acceptability

SECURITY	STANDBY	ECO STANDBY	NO SIGNAL	SHUTTER	FREEZE	TEST PATTERN	REMOTE2	P IN P	LENS HOME
				✓		✓	✓	✓	

3.31. SUB MEMORY REGISTERING [OES]

Hexadecimal	02h	41h	44h	5Ah	5Ah	3Bh	4Fh	45h	53h	03h
Character		A	D	Z	Z	;	O	E	S	

■ Response (Callback)

In the period when the command can be accepted

Hexadecimal	02h	4Fh	45h	53h	03h
Character		O	E	S	

Acceptability

SECURITY	STANDBY	ECO STANDBY	NO SIGNAL	SHUTTER	FREEZE	TEST PATTERN	REMOTE2	P IN P	LENS HOME
				✓		✓	✓	✓	

3.32. SUB MEMORY DELETING [ODS]

Hexadecimal	02h	41h	44h	5Ah	5Ah	3Bh	4Fh	44h	53h	3Ah
Character		A	D	Z	Z	;	O	D	S	:
Hexadecimal	*1	*3	2Dh	*5	*7	03h				
Character	*2	*4	-	*6	*8					

■ Parameters

"mm" of the sub memory number (mm-nn) (*1,*2,*3,*4)

	01		02		03		04	
Hexadecimal	30h	31h	30h	32h	30h	33h	30h	34h
Character	0	1	0	2	0	3	0	4
	92		93		94		95	
Hexadecimal	39h	32h	39h	33h	39h	34h	39h	35h
Character	9	2	9	3	9	4	9	5

"nn" of the sub memory number (mm-nn) (*5,*6,*7,*8)

	01		02		03		04	
Hexadecimal	30h	31h	30h	32h	30h	33h	30h	34h
Character	0	1	0	2	0	3	0	4
	93		94		95		96	
Hexadecimal	39h	33h	39h	34h	39h	35h	39h	36h
Character	9	3	9	4	9	5	9	6

■ Response (Callback)

In the period when the command can be accepted

Hexadecimal	02h	4Fh	44h	53h	3Ah	*1	*3	2Dh
Character		O	D	S	:	*2	*4	-
Hexadecimal	*5	*7	03h					
Character	*6	*8						

Acceptability

SECURITY	STANDBY	ECO STANDBY	NO SIGNAL	SHUTTER	FREEZE	TEST PATTERN	REMOTE2	P IN P	LENS HOME
			✓	✓	✓	✓	✓	✓	

3.33. PICTURE MODE [VPM]

Hexadecimal	02h	41h	44h	5Ah	5Ah	3Bh	56h	50h	4Dh	3Ah
Character		A	D	Z	Z	;	V	P	M	:
Hexadecimal	*1	*3	*5	03h						
Character	*2	*4	*6							

■ Parameters (*1,*2,*3,*4,*5,*6)

	NATURAL			STANDARD			DYNAMIC		
Hexadecimal	4Eh	41h	54h	53h	54h	44h	44h	59h	4Eh
Character	N	A	T	S	T	D	D	Y	N
	CINEMA			GRAPHIC			EASY DICOM		
Hexadecimal	43h	49h	4Eh	47h	52h	41h	44h	49h	43h
Character	C	I	N	G	R	A	D	I	C
	REC709								
Hexadecimal	37h	30h	39h						
Character	7	0	9						

■ Response (Callback)

In the period when the command can be accepted

Hexadecimal	02h	56h	50h	4Dh	3Ah	*1	*3	*5	03h
Character		V	P	M	:	*2	*4	*6	

Acceptability

SECURITY	STANDBY	ECO STANDBY	NO SIGNAL	SHUTTER	FREEZE	TEST PATTERN	REMOTE2	P IN P	LENS HOME
			✓	✓		✓	✓	✓	

3.34. Ye MODULATE [VXX:YEMIO]

Hexadecimal	02h	41h	44h	5Ah	5Ah	3Bh	56h	58h	58h	3Ah
Character		A	D	Z	Z	;	V	X	X	:
Hexadecimal	59h	45h	4Dh	49h	30h	3Dh	2Bh	*1	*3	*5
Character	Y	E	M	I	0	=	+	*2	*4	*6
Hexadecimal	*7	*9	03h							
Character	*8	*10								

■ Parameters (*1,*2,*3,*4,*5,*6,*7,*8,*9,*10)

	OFF					ON				
Hexadecimal	30h	30h	30h	30h	30h	30h	30h	30h	30h	31h
Character	0	0	0	0	0	0	0	0	0	1

■ Response (Callback)

In the period when the command can be accepted

Hexadecimal	02h	56h	58h	58h	3Ah	59h	45h	4Dh	49h	30h
Character		V	X	X	:	Y	E	M	I	0
Hexadecimal	3Dh	2Bh	*1	*3	*5	*7	*9	03h		
Character	=	+	*2	*4	*6	*8	*10			

Acceptability

SECURITY	STANDBY	ECO STANDBY	NO SIGNAL	SHUTTER	FREEZE	TEST PATTERN	REMOTE2	P IN P	LENS HOME
			✓	✓		✓	✓	✓	

3.35. DYNAMIC RGB BOOSTER [VXX:DRBI1]

Hexadecimal	02h	41h	44h	5Ah	5Ah	3Bh	56h	58h	58h	3Ah
Character		A	D	Z	Z	;	V	X	X	:
Hexadecimal	44h	52h	42h	49h	31h	3Dh	2Bh	*1	*3	*5
Character	D	R	B	I	1	=	+	*2	*4	*6
Hexadecimal	*7	*9	03h							
Character	*8	*10								

■ Parameters (*1,*2,*3,*4,*5,*6,*7,*8,*9,*10)

	OFF					1					2				
Hexadecimal	30h	30h	30h	30h	30h	30h	30h	30h	30h	31h	30h	30h	30h	30h	32h
Character	0	0	0	0	0	0	0	0	0	1	0	0	0	0	2
	7														
Hexadecimal	30h	30h	30h	30h	37h										
Character	0	0	0	0	7										

■ Response (Callback)

In the period when the command can be accepted

Hexadecimal	02h	56h	58h	58h	3Ah	44h	52h	42h	49h	31h
Character		V	X	X	:	D	R	B	I	1
Hexadecimal	3Dh	2Bh	*1	*3	*5	*7	*9	03h		
Character	=	+	*2	*4	*6	*8	*10			

Acceptability

SECURITY	STANDBY	ECO STANDBY	NO SIGNAL	SHUTTER	FREEZE	TEST PATTERN	REMOTE2	P IN P	LENS HOME
			✓	✓		✓	✓	✓	

3.36. CONTRAST [VCN]

Hexadecimal	02h	41h	44h	5Ah	5Ah	3Bh	56h	43h	4Eh	3Ah
Character		A	D	Z	Z	;	V	C	N	:
Hexadecimal	*1	*3	*5	03h						
Character	*2	*4	*6							

■ Parameters (*1,*2,*3,*4,*5,*6)

	-31			-30			-29		
Hexadecimal	30h	30h	31h	30h	30h	32h	30h	30h	33h
Character	0	0	1	0	0	2	0	0	3
	+29			+30			+31		
Hexadecimal	30h	36h	31h	30h	36h	32h	30h	36h	33h
Character	0	6	1	0	6	2	0	6	3

■ Response (Callback)

In the period when the command can be accepted

Hexadecimal	02h	56h	43h	4Eh	3Ah	*1	*3	*5	03h
Character		V	C	N	:	*2	*4	*6	

Acceptability

SECURITY	STANDBY	ECO STANDBY	NO SIGNAL	SHUTTER	FREEZE	TEST PATTERN	REMOTE2	P IN P	LENS HOME
				✓		✓	✓	✓	

3.37. BRIGHTNESS [VBR]

Hexadecimal	02h	41h	44h	5Ah	5Ah	3Bh	56h	42h	52h	3Ah
Character		A	D	Z	Z	;	V	B	R	:
Hexadecimal	*1	*3	*5	03h						
Character	*2	*4	*6							

■ Parameters (*1,*2,*3,*4,*5,*6)

	-31			-30			-29		
Hexadecimal	30h	30h	31h	30h	30h	32h	30h	30h	33h
Character	0	0	1	0	0	2	0	0	3
	+29			+30			+31		
Hexadecimal	30h	36h	31h	30h	36h	32h	30h	36h	33h
Character	0	6	1	0	6	2	0	6	3

■ Response (Callback)

In the period when the command can be accepted

Hexadecimal	02h	56h	42h	52h	3Ah	*1	*3	*5	03h
Character		V	B	R	:	*2	*4	*6	

Acceptability

SECURITY	STANDBY	ECO STANDBY	NO SIGNAL	SHUTTER	FREEZE	TEST PATTERN	REMOTE2	P IN P	LENS HOME
				✓		✓	✓	✓	

3.38. COLOR [VCO]

Hexadecimal	02h	41h	44h	5Ah	5Ah	3Bh	56h	43h	4Fh	3Ah
Character		A	D	Z	Z	;	V	C	O	:
Hexadecimal	*1	*3	*5	03h						
Character	*2	*4	*6							

■ Parameters (*1,*2,*3,*4,*5,*6)

	-31			-30			-29		
Hexadecimal	30h	30h	31h	30h	30h	32h	30h	30h	33h
Character	0	0	1	0	0	2	0	0	3
	+29			+30			+31		
Hexadecimal	30h	36h	31h	30h	36h	32h	30h	36h	33h
Character	0	6	1	0	6	2	0	6	3

■ Response (Callback)

In the period when the command can be accepted

Hexadecimal	02h	56h	43h	4Fh	3Ah	*1	*3	*5	03h
Character		V	C	O	:	*2	*4	*6	

Acceptability

SECURITY	STANDBY	ECO STANDBY	NO SIGNAL	SHUTTER	FREEZE	TEST PATTERN	REMOTE2	P IN P	LENS HOME
				✓		✓	✓	✓	

3.39. TINT [VTN]

Hexadecimal	02h	41h	44h	5Ah	5Ah	3Bh	56h	54h	4Eh	3Ah
Character		A	D	Z	Z	;	V	T	N	:
Hexadecimal	*1	*3	*5	03h						
Character	*2	*4	*6							

■ Parameters (*1,*2,*3,*4,*5,*6)

	-31			-30			-29		
Hexadecimal	30h	30h	31h	30h	30h	32h	30h	30h	33h
Character	0	0	1	0	0	2	0	0	3
	+29			+30			+31		
Hexadecimal	30h	36h	31h	30h	36h	32h	30h	36h	33h
Character	0	6	1	0	6	2	0	6	3

■ Response (Callback)

In the period when the command can be accepted

Hexadecimal	02h	56h	54h	4Eh	3Ah	*1	*3	*5	03h
Character		V	T	N	:	*2	*4	*6	

Acceptability

SECURITY	STANDBY	ECO STANDBY	NO SIGNAL	SHUTTER	FREEZE	TEST PATTERN	REMOTE2	P IN P	LENS HOME
				✓		✓	✓	✓	

3.40. COLOR TEMPERATURE [OTE]

Hexadecimal	02h	41h	44h	5Ah	5Ah	3Bh	4Fh	54h	45h	3Ah
Character		A	D	Z	Z	;	O	T	E	:
Hexadecimal	*1	*3	*5	*7	03h					
Character	*2	*4	*6	*8						

■ Parameters (*1,*2,*3,*4,*5,*6,*7,*8)

In the case DEFAULT or USER1, USER2

	DEFAULT		USER1		USER2	
Hexadecimal	31h	30h	30h	34h	30h	39h
Character	1	0	0	4	0	9

When setting COLOR TEMPERATURE

	3200K				3300K			
Hexadecimal	33h	32h	30h	30h	33h	33h	30h	30h
Character	3	2	0	0	3	3	0	0
	9200K				9300K			
Hexadecimal	39h	32h	30h	30h	39h	33h	30h	30h
Character	9	2	0	0	9	3	0	0

■ Response (Callback)

In the period when the command can be accepted

Hexadecimal	02h	4Fh	54h	45h	3Ah	*1	*3	*5	*7	03h
Character		O	T	E	:	*2	*4	*6	*8	

Acceptability

SECURITY	STANDBY	ECO STANDBY	NO SIGNAL	SHUTTER	FREEZE	TEST PATTERN	REMOTE2	P IN P	LENS HOME
			✓	✓		✓	✓	✓	

■ Note:

· Color temperature can be set to 9300K by the 100K unit from 3200K.

3.41. WHITE BALANCE LOW - RED [VOR]

Hexadecimal	02h	41h	44h	5Ah	5Ah	3Bh	56h	4Fh	52h	3Ah
Character		A	D	Z	Z	;	V	O	R	:
Hexadecimal	*1	*3	*5	03h						
Character	*2	*4	*6							

■ Parameters (*1,*2,*3,*4,*5,*6)

	-127			-126			-125		
Hexadecimal	30h	30h	31h	30h	30h	32h	30h	30h	33h
Character	0	0	1	0	0	2	0	0	3
	125			126			127		
Hexadecimal	32h	35h	33h	32h	35h	34h	32h	35h	35h
Character	2	5	3	2	5	4	2	5	5

■ Response (Callback)

In the period when the command can be accepted

Hexadecimal	02h	56h	4Fh	52h	3Ah	*1	*3	*5	03h
Character		V	O	R	:	*2	*4	*6	

Acceptability

SECURITY	STANDBY	ECO STANDBY	NO SIGNAL	SHUTTER	FREEZE	TEST PATTERN	REMOTE2	P IN P	LENS HOME
			✓	✓		✓	✓	✓	

3.42. WHITE BALANCE LOW - GREEN [VOG]

Hexadecimal	02h	41h	44h	5Ah	5Ah	3Bh	56h	4Fh	47h	3Ah
Character		A	D	Z	Z	;	V	O	G	:
Hexadecimal	*1	*3	*5	03h						
Character	*2	*4	*6							

■ Parameters (*1,*2,*3,*4,*5,*6)

	-127			-126			-125		
Hexadecimal	30h	30h	31h	30h	30h	32h	30h	30h	33h
Character	0	0	1	0	0	2	0	0	3
	125			126			127		
Hexadecimal	32h	35h	33h	32h	35h	34h	32h	35h	35h
Character	2	5	3	2	5	4	2	5	5

■ Response (Callback)

In the period when the command can be accepted

Hexadecimal	02h	56h	4Fh	47h	3Ah	*1	*3	*5	03h
Character		V	O	G	:	*2	*4	*6	

Acceptability

SECURITY	STANDBY	ECO STANDBY	NO SIGNAL	SHUTTER	FREEZE	TEST PATTERN	REMOTE2	P IN P	LENS HOME
			✓	✓		✓	✓	✓	

3.43. WHITE BALANCE LOW - BLUE [VOB]

Hexadecimal	02h	41h	44h	5Ah	5Ah	3Bh	56h	4Fh	42h	3Ah
Character		A	D	Z	Z	;	V	O	B	:
Hexadecimal	*1	*3	*5	03h						
Character	*2	*4	*6							

■ Parameters (*1,*2,*3,*4,*5,*6)

	-127			-126			-125		
Hexadecimal	30h	30h	31h	30h	30h	32h	30h	30h	33h
Character	0	0	1	0	0	2	0	0	3
	125			126			127		
Hexadecimal	32h	35h	33h	32h	35h	34h	32h	35h	35h
Character	2	5	3	2	5	4	2	5	5

■ Response (Callback)

In the period when the command can be accepted

Hexadecimal	02h	56h	4Fh	42h	3Ah	*1	*3	*5	03h
Character		V	O	B	:	*2	*4	*6	

Acceptability

SECURITY	STANDBY	ECO STANDBY	NO SIGNAL	SHUTTER	FREEZE	TEST PATTERN	REMOTE2	P IN P	LENS HOME
			✓	✓		✓	✓	✓	

3.44. WHITE BALANCE HIGH - RED [VHR]

Hexadecimal	02h	41h	44h	5Ah	5Ah	3Bh	56h	48h	52h	3Ah
Character		A	D	Z	Z	;	V	H	R	:
Hexadecimal	*1	*3	*5	03h						
Character	*2	*4	*6							

■ Parameters (*1,*2,*3,*4,*5,*6)

	0			1			2		
Hexadecimal	30h	30h	30h	30h	30h	31h	30h	30h	32h
Character	0	0	0	0	0	1	0	0	2
	253			254			255		
Hexadecimal	32h	35h	33h	32h	35h	34h	32h	35h	35h
Character	2	5	3	2	5	4	2	5	5

■ Response (Callback)

In the period when the command can be accepted

Hexadecimal	02h	56h	48h	52h	3Ah	*1	*3	*5	03h
Character		V	H	R	:	*2	*4	*6	

Acceptability

SECURITY	STANDBY	ECO STANDBY	NO SIGNAL	SHUTTER	FREEZE	TEST PATTERN	REMOTE2	P IN P	LENS HOME
			✓	✓		✓	✓	✓	

3.45. WHITE BALANCE HIGH - GREEN [VHG]

Hexadecimal	02h	41h	44h	5Ah	5Ah	3Bh	56h	48h	47h	3Ah
Character		A	D	Z	Z	;	V	H	G	:
Hexadecimal	*1	*3	*5	03h						
Character	*2	*4	*6							

■ Parameters (*1,*2,*3,*4,*5,*6)

	0			1			2		
Hexadecimal	30h	30h	30h	30h	30h	31h	30h	30h	32h
Character	0	0	0	0	0	1	0	0	2
	253			254			255		
Hexadecimal	32h	35h	33h	32h	35h	34h	32h	35h	35h
Character	2	5	3	2	5	4	2	5	5

■ Response (Callback)

In the period when the command can be accepted

Hexadecimal	02h	56h	48h	47h	3Ah	*1	*3	*5	03h
Character		V	H	G	:	*2	*4	*6	

Acceptability

SECURITY	STANDBY	ECO STANDBY	NO SIGNAL	SHUTTER	FREEZE	TEST PATTERN	REMOTE2	P IN P	LENS HOME
			✓	✓		✓	✓	✓	

3.46. WHITE BALANCE HIGH - BLUE [VHB]

Hexadecimal	02h	41h	44h	5Ah	5Ah	3Bh	56h	48h	42h	3Ah
Character		A	D	Z	Z	;	V	H	B	:
Hexadecimal	*1	*3	*5	03h						
Character	*2	*4	*6							

■ Parameters (*1,*2,*3,*4,*5,*6)

	0			1			2		
Hexadecimal	30h	30h	30h	30h	30h	31h	30h	30h	32h
Character	0	0	0	0	0	1	0	0	2
	253			254			255		
Hexadecimal	32h	35h	33h	32h	35h	34h	32h	35h	35h
Character	2	5	3	2	5	4	2	5	5

■ Response (Callback)

In the period when the command can be accepted

Hexadecimal	02h	56h	48h	42h	3Ah	*1	*3	*5	03h
Character		V	H	B	:	*2	*4	*6	

Acceptability

SECURITY	STANDBY	ECO STANDBY	NO SIGNAL	SHUTTER	FREEZE	TEST PATTERN	REMOTE2	P IN P	LENS HOME
			✓	✓		✓	✓	✓	

3.47. NAME SETTING - COLOR TEMPERATURE USER1 [VXX:NCGS1]

Hexadecimal	02h	41h	44h	5Ah	5Ah	3Bh	56h	58h	58h	3Ah
Character		A	D	Z	Z	;	V	X	X	:
Hexadecimal	4Eh	43h	47h	53h	31h	3Dh	*1	*3	*5	*7
Character	N	C	G	S	1	=	*2	*4	*6	*8
Hexadecimal	*9	*11	*13	*15	*17	*19	*21	*23	*25	*27
Character	*10	*12	*14	*16	*18	*20	*22	*24	*26	*28
Hexadecimal	*29	03h								
Character	*30									

■ Parameters (*1,*2,...,*29,*30)

	Name									
Hexadecimal	n1h	n2h	n3h	...			n14h	n15h		
Character	p1	p2	p3	...			p14	p15		

■ Response (Callback)

In the period when the command can be accepted

Hexadecimal	02h	56h	58h	58h	3Ah	4Eh	43h	47h	53h	31h
Character		V	X	X	:	N	C	G	S	1
Hexadecimal	3Dh	*1	*3	*5	*7	*9	*11	*13	*15	*17
Character	=	*2	*4	*6	*8	*10	*12	*14	*16	*18
Hexadecimal	*19	*21	*23	*25	*27	*29	03h			
Character	*20	*22	*24	*26	*28	*30				

Acceptability

SECURITY	STANDBY	ECO STANDBY	NO SIGNAL	SHUTTER	FREEZE	TEST PATTERN	REMOTE2	P IN P	LENS HOME
			✓	✓		✓	✓	✓	

■ Note:

· Name is set by the undefined length.

3.48. NAME SETTING - COLOR TEMPERATURE USER2 [VXX:NCGS3]

Hexadecimal	02h	41h	44h	5Ah	5Ah	3Bh	56h	58h	58h	3Ah
Character		A	D	Z	Z	;	V	X	X	:
Hexadecimal	4Eh	43h	47h	53h	33h	3Dh	*1	*3	*5	*7
Character	N	C	G	S	3	=	*2	*4	*6	*8
Hexadecimal	*9	*11	*13	*15	*17	*19	*21	*23	*25	*27
Character	*10	*12	*14	*16	*18	*20	*22	*24	*26	*28
Hexadecimal	*29	03h								
Character	*30									

■ Parameters (*1,*2,...,*29,*30)

	Name					
Hexadecimal	n1h	n2h	n3h	...	n14h	n15h
Character	p1	p2	p3	...	p14	p15

■ Response (Callback)

In the period when the command can be accepted

Hexadecimal	02h	56h	58h	58h	3Ah	4Eh	43h	47h	53h	33h
Character		V	X	X	:	N	C	G	S	3
Hexadecimal	3Dh	*1	*3	*5	*7	*9	*11	*13	*15	*17
Character	=	*2	*4	*6	*8	*10	*12	*14	*16	*18
Hexadecimal	*19	*21	*23	*25	*27	*29	03h			
Character	*20	*22	*24	*26	*28	*30				

Acceptability

SECURITY	STANDBY	ECO STANDBY	NO SIGNAL	SHUTTER	FREEZE	TEST PATTERN	REMOTE2	P IN P	LENS HOME
			✓	✓		✓	✓	✓	

■ Note:

· Name is set by the undefined length.

3.49. WHITE GAIN [VWH]

Hexadecimal	02h	41h	44h	5Ah	5Ah	3Bh	56h	57h	48h	3Ah
Character		A	D	Z	Z	;	V	W	H	:
Hexadecimal	*1	*3	03h							
Character	*2	*4								

■ Parameters (*1,*2,*3,*4)

	0		1		9		10	
Hexadecimal	30h	30h	30h	31h	30h	39h	31h	30h
Character	0	0	0	0	0	9	1	0

■ Response (Callback)

In the period when the command can be accepted

Hexadecimal	02h	56h	57h	48h	3Ah	*1	*3	03h
Character		V	W	H	:	*2	*4	

Acceptability

SECURITY	STANDBY	ECO STANDBY	NO SIGNAL	SHUTTER	FREEZE	TEST PATTERN	REMOTE2	P IN P	LENS HOME
			✓	✓		✓	✓		

3.50. GAMMA MODE [VGA]

Hexadecimal	02h	41h	44h	5Ah	5Ah	3Bh	56h	47h	41h	3Ah
Character		A	D	Z	Z	;	V	G	A	:
Hexadecimal	*1	*3	*5	03h						
Character	*2	*4	*6							

■ Parameters (*1,*2,*3,*4,*5,*6)

	1.8			2.0			2.0		
Hexadecimal	31h	2Eh	30h	31h	2Eh	38h	32h	2Eh	30h
Character	1	.	8	2	.	0	2	.	2

■ Response (Callback)

In the period when the command can be accepted

Hexadecimal	02h	56h	47h	41h	3Ah	*1	*3	*5	03h
Character		V	G	A	:	*2	*4	*6	

Acceptability

SECURITY	STANDBY	ECO STANDBY	NO SIGNAL	SHUTTER	FREEZE	TEST PATTERN	REMOTE2	P IN P	LENS HOME
			✓	✓		✓	✓	✓	

3.51. SYSTEM DAYLIGHT VIEW [VXX:DLVIO]

Hexadecimal	02h	41h	44h	5Ah	5Ah	3Bh	56h	58h	58h	3Ah
Character		A	D	Z	Z	;	V	X	X	:
Hexadecimal	44h	4Ch	56h	49h	30h	3Dh	2Bh	*1	*3	*5
Character	D	L	V	I	0	=	+	*2	*4	*6
Hexadecimal	*7	*9	03h							
Character	*8	*10								

■ Parameters (*1,*2,*3,*4,*5,*6,*7,*8,*9,*10)

	OFF					1					2				
Hexadecimal	30h	30h	30h	30h	30h	30h	30h	30h	30h	31h	30h	30h	30h	30h	32h
Character	0	0	0	0	0	0	0	0	0	1	0	0	0	0	2
	3														
Hexadecimal	30h	30h	30h	30h	33h										
Character	0	0	0	0	3										

■ Response (Callback)

In the period when the command can be accepted

Hexadecimal	02h	56h	58h	58h	3Ah	44h	4C	56h	49h	30h
Character		V	X	X	:	D	L	V	I	0
Hexadecimal	3Dh	2Bh	*1	*3	*5	*7	*9	03h		
Character	=	+	*2	*4	*6	*8	*10			

Acceptability

SECURITY	STANDBY	ECO STANDBY	NO SIGNAL	SHUTTER	FREEZE	TEST PATTERN	REMOTE2	P IN P	LENS HOME
			✓	✓		✓	✓	✓	

3.52. SHARPNESS [VSR]

Hexadecimal	02h	41h	44h	5Ah	5Ah	3Bh	56h	53h	52h	3Ah
Character		A	D	Z	Z	;	V	S	R	:
Hexadecimal	*1	*3	*5	03h						
Character	*2	*4	*6							

■ Parameters (*1,*2,*3,*4,*5,*6)

	0			1			2		
Hexadecimal	30h	30h	30h	30h	30h	31h	30h	30h	32h
Character	0	0	0	0	0	1	0	0	2
	13			14			15		
Hexadecimal	30h	31h	33h	30h	31h	34h	30h	31h	35h
Character	0	1	3	0	1	4	0	1	5

■ Response (Callback)

In the period when the command can be accepted

Hexadecimal	02h	56h	53h	52h	3Ah	*1	*3	*5	03h
Character		V	S	R	:	*2	*4	*6	

Acceptability

SECURITY	STANDBY	ECO STANDBY	NO SIGNAL	SHUTTER	FREEZE	TEST PATTERN	REMOTE2	P IN P	LENS HOME
				✓		✓	✓	✓	

3.53. NOISE REDUCTION [VNS]

Hexadecimal	02h	41h	44h	5Ah	5Ah	3Bh	56h	4Eh	53h	3Ah
Character		A	D	Z	Z	;	V	N	S	:
Hexadecimal	*1	03h								
Character	*2									

■ Parameters (*1,*2)

	OFF		1		2		3	
Hexadecimal	30h		31h		32h		33h	
Character	0		1		2		3	

■ Response (Callback)

In the period when the command can be accepted

Hexadecimal	02h	56h	4Eh	53h	3Ah	*1	03h
Character		V	N	S	:	*2	

Acceptability

SECURITY	STANDBY	ECO STANDBY	NO SIGNAL	SHUTTER	FREEZE	TEST PATTERN	REMOTE2	P IN P	LENS HOME
				✓		✓	✓	✓	

3.54. AI [OAI]

Hexadecimal	02h	41h	44h	5Ah	5Ah	3Bh	4Fh	41h	49h	3Ah
Character		A	D	Z	Z	;	O	A	I	:
Hexadecimal	*1	03h								
Character	*2									

■ Parameters (*1,*2)

	OFF	ON
Hexadecimal	30h	31h
Character	0	1

■ Response (Callback)

In the period when the command can be accepted

Hexadecimal	02h	4Fh	41h	49h	3Ah	*1	03h
Character		O	A	I	:	*2	

Acceptability

SECURITY	STANDBY	ECO STANDBY	NO SIGNAL	SHUTTER	FREEZE	TEST PATTERN	REMOTE2	P IN P	LENS HOME
			✓	✓		✓	✓	✓	

3.55. SYSTEM SELECTOR (VIDEO / Y/C) [VSG]

Hexadecimal	02h	41h	44h	5Ah	5Ah	3Bh	56h	53h	47h	3Ah
Character		A	D	Z	Z	;	V	S	G	:
Hexadecimal	*1	*3	*5	03h						
Character	*2	*4	*6							

■ Parameters (*1,*2,*3,*4,*5,*6)

	AUTO						NTSC		
Hexadecimal	41h	54h	31h	41h	54h	32h	4Eh	54h	53h
Character	A	T	1	A	T	2	N	T	S
	NTSC4.43			PAL			PAL-M		
Hexadecimal	4Eh	34h	34h	50h	41h	4Ch	50h	41h	4Dh
Character	N	4	4	P	A	L	P	A	M
	PAL-N			SECAM			PAL60		
Hexadecimal	50h	41h	4Eh	53h	45h	43h	50h	36h	30h
Character	P	A	N	S	E	C	P	6	0

■ Response (Callback)

In the period when the command can be accepted

Hexadecimal	02h	56h	53h	47h	3Ah	*1	*3	*5	03h
Character		V	S	G	:	*2	*4	*6	

Acceptability

SECURITY	STANDBY	ECO STANDBY	NO SIGNAL	SHUTTER	FREEZE	TEST PATTERN	REMOTE2	P IN P	LENS HOME
			✓	✓		✓	✓	✓	

3.56. SYSTEM SELECTOR (RGB/DVI-D/HDMI/DIGITAL LINK) [ORF]

Hexadecimal	02h	41h	44h	5Ah	5Ah	3Bh	4Fh	52h	46h	3Ah
Character		A	D	Z	Z	;	O	R	F	:
Hexadecimal	*1	03h								
Character	*2									

■ Parameters (*1,*2)

·RGB(VGA/480P)

	VGA60	480P(YCBCR)	480pRGB
Hexadecimal	30h	31h	33h
Character	0	1	3

·RGB(Other)/DVI

	RGB	YPBPR
Hexadecimal	30h	31h
Character	0	1

·HDMI/DIGITAL LINK

	RGB	YPBPR	AUTO
Hexadecimal	30h	31h	32h
Character	0	1	2

■ Response (Callback)

In the period when the command can be accepted

Hexadecimal	02h	4Fh	52h	46h	3Ah	*1	03h
Character		O	R	F	:	*2	

Acceptability

SECURITY	STANDBY	ECO STANDBY	NO SIGNAL	SHUTTER	FREEZE	TEST PATTERN	REMOTE2	P IN P	LENS HOME
				✓		✓	✓	✓	

3.57. SYSTEM SELECTOR (SDI) [VSD]

Hexadecimal	02h	41h	44h	5Ah	5Ah	3Bh	56h	53h	44h	3Ah
Character		A	D	Z	Z	;	V	S	D	:
Hexadecimal	*1	*3	03h							
Character	*2	*4								

■ Parameters (*1,*2,*3,*4)

	AUTO		480i YBCBR		576i YBCBR	
Hexadecimal	30h		31h		33h	
Character	0		1		3	
	1080/60i YPBPR		1035/60i YPBPR		720/60p YPBPR	
Hexadecimal	34h		35h		36h	
Character	4		5		6	
	1080/24p YPBPR		1080/50i YPBPR		1080/30p YPBPR	
Hexadecimal	37h		38h		39h	
Character	7		8		9	
	1080/25p YPBPR		1080/24sF YPBPR		720/50p YPBPR	
Hexadecimal	31h	30h	31h	31h	31h	32h
Character	1	0	1	1	1	2
	1080/50p YPBPR		1080/60p YPBPR		1080/24p RGB	
Hexadecimal	31h	35h	31h	36h	32h	31h
Character	1	5	1	6	2	1
	1080/24sF RGB		1080/25p RGB		1080/30p RGB	
Hexadecimal	32h	32h	32h	33h	32h	34h
Character	2	2	2	3	2	4
	1080/50i RGB		1080/60i RGB			
Hexadecimal	32h	35h	32h	36h		
Character	2	5	2	6		

■ Response (Callback)

In the period when the command can be accepted

Hexadecimal	02h	56h	53h	44h	3Ah	*1	*3	03h
Character		V	S	D	:	*2	*4	

Acceptability

SECURITY	STANDBY	ECO STANDBY	NO SIGNAL	SHUTTER	FREEZE	TEST PATTERN	REMOTE2	P IN P	LENS HOME
			✓	✓		✓	✓	✓	

■ Note:

· It is only effective for DZ780(FDZ88C), other models return ER401.

3.58. SHIFT - HORIZONTAL [VTH]

Hexadecimal	02h	41h	44h	5Ah	5Ah	3Bh	56h	54h	48h	3Ah
Character		A	D	Z	Z	;	V	T	H	:
Hexadecimal	*1	*3	*5	*7	03h					
Character	*2	*4	*6	*8						

■ Parameters (*1,*2,*3,*4,*5,*6,*7,*8)

	0				1				2			
Hexadecimal	30h	30h	30h	30h	30h	30h	30h	31h	30h	30h	30h	32h
Character	0	0	0	0	0	0	0	1	0	0	0	2
	4093				4094				4095			
Hexadecimal	34h	30h	39h	33h	34h	30h	39h	34h	34h	30h	39h	35h
Character	4	0	9	3	4	0	9	4	4	0	9	5

■ Response (Callback)

In the period when the command can be accepted

Hexadecimal	02h	56h	54h	48h	3Ah	*1	*3	*5	*7	03h
Character		V	T	H	:	*2	*4	*6	*8	

Acceptability

SECURITY	STANDBY	ECO STANDBY	NO SIGNAL	SHUTTER	FREEZE	TEST PATTERN	REMOTE2	P IN P	LENS HOME
				✓		✓	✓	✓	

■ Note:

· Adjustable maximum value varies according to the input resolution or set the input signal.
· Minimum value : 0, Maximum value : Total dots -1

3.59. SHIFT - VERTICAL [VTV]

Hexadecimal	02h	41h	44h	5Ah	5Ah	3Bh	56h	54h	56h	3Ah
Character		A	D	Z	Z	;	V	T	V	:
Hexadecimal	*1	*3	*5	*7	03h					
Character	*2	*4	*6	*8						

■ Parameters (*1,*2,*3,*4,*5,*6,*7,*8)

	0				1				2			
Hexadecimal	30h	30h	30h	30h	30h	30h	30h	31h	30h	30h	30h	32h
Character	0	0	0	0	0	0	0	1	0	0	0	2
	4092				4093				4094			
Hexadecimal	34h	30h	39h	32h	34h	30h	39h	33h	34h	30h	39h	34h
Character	4	0	9	2	4	0	9	3	4	0	9	4

■ Response (Callback)

In the period when the command can be accepted

Hexadecimal	02h	56h	54h	56h	3Ah	*1	*3	*5	*7	03h
Character		V	T	V	:	*2	*4	*6	*8	

Acceptability

SECURITY	STANDBY	ECO STANDBY	NO SIGNAL	SHUTTER	FREEZE	TEST PATTERN	REMOTE2	P IN P	LENS HOME
				✓		✓	✓	✓	

■ Note:

- Adjustable maximum value varies according to the input resolution or set the input signal.
- Minimum value : 0, maximum value : Total lines -1

3.60. ASPECT [VSE]

Hexadecimal	02h	41h	44h	5Ah	5Ah	3Bh	56h	53h	45h	3Ah
Character		A	D	Z	Z	;	V	S	E	:
Hexadecimal	*1	*3	03h							
Character	*2	*4								

■ Parameters (*1,*2,*3,*4)

· Input terminal : VIDEO/RGB1(Y/C), Input signal: NTSC

	VID AUTO		4:3	16:9	THROUGH	HV FIT
Hexadecimal	30h		31h	32h	35h	36h
Character	0		1	2	5	6
	H FIT		V FIT			
Hexadecimal	39h		31h	30h		
Character	9		1	0		

· Input terminal / signal : RGB1(RGB/YpbPr)/RGB2(480i,480p)

	AUTO		4:3	16:9	THROUGH	HV FIT
Hexadecimal	30h		31h	32h	35h	36h
Character	0		1	2	5	6
	H FIT		V FIT			
Hexadecimal	39h		31h	30h		
Character	9		1	0		

· Input terminal / signal : Other than those above

	DEFAULT		4:3	16:9	THROUGH	HV FIT
Hexadecimal	30h		31h	32h	35h	36h
Character	0		1	2	5	6
	H FIT		V FIT			
Hexadecimal	39h		31h	30h		
Character	9		1	0		

■ Response (Callback)

In the period when the command can be accepted

Hexadecimal	02h	56h	53h	45h	3Ah	*1	*3	03h
Character		V	S	E	:	*2	*4	

Acceptability

SECURITY	STANDBY	ECO STANDBY	NO SIGNAL	SHUTTER	FREEZE	TEST PATTERN	REMOTE2	P IN P	LENS HOME
				✓		✓	✓	✓	

3.61. ZOOM - HORIZONTAL [OZH]

Hexadecimal	02h	41h	44h	5Ah	5Ah	3Bh	4Fh	5Ah	48h	3Ah
Character		A	D	Z	Z	;	O	Z	H	:
Hexadecimal	*1	*3	*5	03h						
Character	*2	*4	*6							

■ Parameters (*1,*2,*3,*4,*5,*6)

	50			51			52		
Hexadecimal	30h	35h	30h	30h	35h	31h	30h	35h	32h
Character	0	5	0	0	5	1	0	5	2
	997			998			999		
Hexadecimal	39h	39h	37h	39h	39h	38h	39h	39h	39h
Character	9	9	7	9	9	8	9	9	9

■ Response (Callback)

In the period when the command can be accepted

Hexadecimal	02h	4Fh	5Ah	48h	3Ah	*1	*3	*5	03h
Character		O	Z	H	:	*2	*4	*6	

Acceptability

SECURITY	STANDBY	ECO STANDBY	NO SIGNAL	SHUTTER	FREEZE	TEST PATTERN	REMOTE2	P IN P	LENS HOME
				✓			✓	✓	

3.62. ZOOM - VERTICAL [OZV]

Hexadecimal	02h	41h	44h	5Ah	5Ah	3Bh	4Fh	5Ah	56h	3Ah
Character		A	D	Z	Z	;	O	Z	V	:
Hexadecimal	*1	*3	*5	03h						
Character	*2	*4	*6							

■ Parameters (*1,*2,*3,*4,*5,*6)

	50			51			52		
Hexadecimal	30h	35h	30h	30h	35h	31h	30h	35h	32h
Character	0	5	0	0	5	1	0	5	2
	997			998			999		
Hexadecimal	39h	39h	37h	39h	39h	38h	39h	39h	39h
Character	9	9	7	9	9	8	9	9	9

■ Response (Callback)

In the period when the command can be accepted

Hexadecimal	02h	4Fh	5Ah	56h	3Ah	*1	*3	*5	03h
Character		O	Z	V	:	*2	*4	*6	

Acceptability

SECURITY	STANDBY	ECO STANDBY	NO SIGNAL	SHUTTER	FREEZE	TEST PATTERN	REMOTE2	P IN P	LENS HOME
				✓			✓	✓	

3.63. ZOOM - HORIZONTAL / VERTICAL [OZO]

Hexadecimal	02h	41h	44h	5Ah	5Ah	3Bh	4Fh	5Ah	4Fh	3Ah
Character		A	D	Z	Z	;	O	Z	O	:
Hexadecimal	*1	*3	*5	03h						
Character	*2	*4	*6							

■ Parameters (*1,*2,*3,*4,*5,*6)

	50			51			52		
Hexadecimal	30h	35h	30h	30h	35h	31h	30h	35h	32h
Character	0	5	0	0	5	1	0	5	2
	997			998			999		
Hexadecimal	39h	39h	37h	39h	39h	38h	39h	39h	39h
Character	9	9	7	9	9	8	9	9	9

■ Response (Callback)

In the period when the command can be accepted

Hexadecimal	02h	4Fh	5Ah	4Fh	3Ah	*1	*3	*5	03h
Character		O	Z	O	:	*2	*4	*6	

Acceptability

SECURITY	STANDBY	ECO STANDBY	NO SIGNAL	SHUTTER	FREEZE	TEST PATTERN	REMOTE2	P IN P	LENS HOME
				✓			✓	✓	

3.64. ZOOM - INTERLOCKED [OZS]

Hexadecimal	02h	41h	44h	5Ah	5Ah	3Bh	4Fh	5Ah	53h	3Ah
Character		A	D	Z	Z	;	O	Z	S	:
Hexadecimal	*1	03h								
Character	*2									

■ Parameters (*1,*2)

	OFF	ON
Hexadecimal	30h	31h
Character	0	1

■ Response (Callback)

In the period when the command can be accepted

Hexadecimal	02h	4Fh	5Ah	53h	3Ah	*1	03h
Character		O	Z	S	:	*2	

Acceptability

SECURITY	STANDBY	ECO STANDBY	NO SIGNAL	SHUTTER	FREEZE	TEST PATTERN	REMOTE2	P IN P	LENS HOME
				✓			✓	✓	

3.65. ZOOM - MODE [OZT]

Hexadecimal	02h	41h	44h	5Ah	5Ah	3Bh	4Fh	5Ah	54h	3Ah
Character		A	D	Z	Z	;	O	Z	T	:
Hexadecimal	*1	03h								
Character	*2									

■ Parameters (*1,*2)

	INTERNAL	FULL
Hexadecimal	30h	31h
Character	0	1

■ Response (Callback)

In the period when the command can be accepted

Hexadecimal	02h	4Fh	5Ah	54h	3Ah	*1	03h
Character		O	Z	T	:	*2	

Acceptability

SECURITY	STANDBY	ECO STANDBY	NO SIGNAL	SHUTTER	FREEZE	TEST PATTERN	REMOTE2	P IN P	LENS HOME
				✓			✓	✓	

■ Note:

· It is only effective for DEFAULT setting of ASPECT.

3.66. CLOCK PHASE [VCP]

Hexadecimal	02h	41h	44h	5Ah	5Ah	3Bh	56h	43h	50h	3Ah
Character		A	D	Z	Z	;	V	C	P	:
Hexadecimal	*1	*3	*5	03h						
Character	*2	*4	*6							

■ Parameters (*1,*2,*3,*4,*5,*6)

	0			1			2		
Hexadecimal	30h	30h	30h	30h	30h	31h	30h	30h	32h
Character	0	0	0	0	0	1	0	0	2
	29			30			31		
Hexadecimal	30h	32h	39h	30h	33h	30h	30h	33h	31h
Character	0	2	9	0	3	0	0	3	1

■ Response (Callback)

In the period when the command can be accepted

Hexadecimal	02h	56h	43h	50h	3Ah	*1	*3	*5	03h
Character		V	C	P	:	*2	*4	*6	

Acceptability

SECURITY	STANDBY	ECO STANDBY	NO SIGNAL	SHUTTER	FREEZE	TEST PATTERN	REMOTE2	P IN P	LENS HOME
				✓			✓	✓	

■ Note:

· It is only effective for input selection of RGB1 or RGB2.

3.67. GEOMETRY [VXX:GMMI0]

Hexadecimal	02h	41h	44h	5Ah	5Ah	3Bh	56h	58h	58h	3Ah
Character		A	D	Z	Z	;	V	X	X	:
Hexadecimal	47h	4Dh	4Dh	49h	30h	3Dh	2Bh	*1	*3	*5
Character	G	M	M	I	0	=	+	*2	*4	*6
Hexadecimal	*7	*9	03h							
Character	*8	*10								

■ Parameters (*1,*2,*3,*4,*5,*6,*7,*8,*9,*10)

	OFF					KEystone				
Hexadecimal	30h	30h	30h	30h	30h	30h	30h	30h	30h	31h
Character	0	0	0	0	0	0	0	0	0	1
	CURVED					PC1				
Hexadecimal	30h	30h	30h	30h	32h	30h	30h	30h	30h	33h
Character	0	0	0	0	2	0	0	0	0	3
	PC2					PC3				
Hexadecimal	30h	30h	30h	30h	34h	30h	30h	30h	30h	35h
Character	0	0	0	0	4	0	0	0	0	5
	CORNER CORRECTION									
Hexadecimal	30h	30h	30h	31h	30h					
Character	0	0	0	1	0					

■ Response (Callback)

In the period when the command can be accepted

Hexadecimal	02h	56h	58h	58h	3Ah	47h	4Dh	4Dh	49h	30h
Character		V	X	X	:	G	M	M	I	0
Hexadecimal	3Dh	2Bh	*1	*3	*5	*7	*9	03h		
Character	=	+	*2	*4	*6	*8	*10			

Acceptability

SECURITY	STANDBY	ECO STANDBY	NO SIGNAL	SHUTTER	FREEZE	TEST PATTERN	REMOTE2	P IN P	LENS HOME
	✓		✓	✓		✓	✓	✓	

■ Note:

· It is only effective for DZ780(FDZ88C), other models return ER401.

3.68. GEOMETRY : KEystone - LENS THROW RATIO [VXX:GMKS0]

Hexadecimal	02h	41h	44h	5Ah	5Ah	3Bh	56h	58h	58h	3Ah
Character		A	D	Z	Z	;	V	X	X	:
Hexadecimal	47h	4Dh	4Bh	53h	30h	3Dh	2Bh	*1	*3	*5
Character	G	M	K	S	0	=	+	*2	*4	*6
Hexadecimal	*7	03h								
Character	*8									

■ Parameters (*1,*2,*3,*4,*5,*6,*7,*8)

	0.7				0.8					
Hexadecimal	30h	30h	2Eh	37h	30h	30h	2Eh	38h		
Character	0	0	.	7	0	0	.	8		
	16.4				16.5					
Hexadecimal	31h	36h	2Eh	34h	31h	36h	2Eh	35h		
Character	1	6	.	4	1	6	.	5		

■ Response (Callback)

In the period when the command can be accepted

Hexadecimal	02h	56h	58h	58h	3Ah	47h	4Dh	4Bh	53h	30h
Character		V	X	X	:	G	M	K	S	0
Hexadecimal	3Dh	2Bh	*1	*3	*5	*7	03h			
Character	=	+	*2	*4	*6	*8				

Acceptability

SECURITY	STANDBY	ECO STANDBY	NO SIGNAL	SHUTTER	FREEZE	TEST PATTERN	REMOTE2	P IN P	LENS HOME
	✓		✓	✓		✓	✓	✓	

■ Note:

· It is only effective for DZ780(FDZ88C), other models return ER401.

· Character can be set numbers and decimal separator.

· Will be set to 0.7 to 16.5 in 0.1 increments.

3.69. GEOMETRY : KEYSTONE - VERTICAL BALANCE [VXX:GMKI4]

Hexadecimal	02h	41h	44h	5Ah	5Ah	3Bh	56h	58h	58h	3Ah
Character		A	D	Z	Z	;	V	X	X	:
Hexadecimal	47h	4Dh	4Bh	49h	34h	3Dh	*1	*3	*5	*7
Character	G	M	K	l	4	=	*2	*4	*6	*8
Hexadecimal	*9	*11	03h							
Character	*10	*12								

■ Parameters (*1,*2,*3,*4,*5,*6,*7,*8,*9,*10,*11,*12)

	-60						-59					
Hexadecimal	2Dh	30h	30h	30h	36h	30h	2Dh	30h	30h	30h	35h	39h
Character	—	0	0	0	6	0	—	0	0	0	5	9
	+59						+60					
Hexadecimal	2Bh	30h	30h	30h	35h	39h	2Bh	30h	30h	30h	36h	30h
Character	+	0	0	0	5	9	+	0	0	0	6	0

■ Response (Callback)

In the period when the command can be accepted

Hexadecimal	02h	56h	58h	58h	3Ah	47h	4Dh	4Bh	49h	34h
Character		V	X	X	:	G	M	K	l	4
Hexadecimal	3Dh	*1	*3	*5	*7	*9	*11	03h		
Character	=	*2	*4	*6	*8	*10	*12			

Acceptability

SECURITY	STANDBY	ECO STANDBY	NO SIGNAL	SHUTTER	FREEZE	TEST PATTERN	REMOTE2	P IN P	LENS HOME
	✓		✓	✓		✓	✓	✓	

■ Note:

· It is only effective for DZ780(FDZ88C), other models return ER401.

3.70. GEOMETRY : KEYSTONE - HORIZONTAL BALANCE [VXX:GMKI7]

Hexadecimal	02h	41h	44h	5Ah	5Ah	3Bh	56h	58h	58h	3Ah
Character		A	D	Z	Z	;	V	X	X	:
Hexadecimal	47h	4Dh	4Bh	49h	37h	3Dh	*1	*3	*5	*7
Character	G	M	K	l	7	=	*2	*4	*6	*8
Hexadecimal	*9	*11	03h							
Character	*10	*12								

■ Parameters (*1,*2,*3,*4,*5,*6,*7,*8,*9,*10,*11,*12)

	-30						-29					
Hexadecimal	2Dh	30h	30h	30h	33h	30h	2Dh	30h	30h	30h	32h	39h
Character	—	0	0	0	3	0	—	0	0	0	2	9
	+29						+30					
Hexadecimal	2Bh	30h	30h	30h	32h	39h	2Bh	30h	30h	30h	33h	30h
Character	+	0	0	0	2	9	+	0	0	0	3	0

■ Response (Callback)

In the period when the command can be accepted

Hexadecimal	02h	56h	58h	58h	3Ah	47h	4Dh	4Bh	49h	37h
Character		V	X	X	:	G	M	K	l	7
Hexadecimal	3Dh	*1	*3	*5	*7	*9	*11	03h		
Character	=	*2	*4	*6	*8	*10	*12			

Acceptability

SECURITY	STANDBY	ECO STANDBY	NO SIGNAL	SHUTTER	FREEZE	TEST PATTERN	REMOTE2	P IN P	LENS HOME
	✓		✓	✓		✓	✓	✓	

■ Note:

· It is only effective for DZ780(FDZ88C), other models return ER401.

3.71. GEOMETRY : KEYSTONE - VERTICAL KEYSTONE [VXX:GMKS8]

Hexadecimal	02h	41h	44h	5Ah	5Ah	3Bh	56h	58h	58h	3Ah
Character		A	D	Z	Z	;	V	X	X	:
Hexadecimal	47h	4Dh	4Bh	53h	38h	3Dh	*1	*3	*5	*7
Character	G	M	K	S	8	=	*2	*4	*6	*8
Hexadecimal	*9	03h								
Character	*10									

■ Parameters (*1,*2,*3,*4,*5,*6,*7,*8,*9,*10)

	-40.0					-38.8				
Hexadecimal	2Dh	34h	30h	2Eh	30h	2Dh	33h	38h	2Eh	38h
Character	-	4	0	.	0	-	3	8	.	8
	-9.8					+00.0				
Hexadecimal	2Dh	30h	39h	2Eh	38h	2Bh	30h	30h	2Eh	30h
Character	-	0	9	.	8	+	0	0	.	0
	+38.8					+40.0				
Hexadecimal	2Bh	33h	38h	2Eh	38h	2Bh	34h	30h	2Eh	30h
Character	+	3	8	.	8	+	4	0	.	0

■ Response (Callback)

In the period when the command can be accepted

Hexadecimal	02h	56h	58h	58h	3Ah	47h	4Dh	4Bh	53h	38h
Character		V	X	X	:	G	M	K	S	8
Hexadecimal	3Dh	*1	*3	*5	*7	*9	03h			
Character	=	*2	*4	*6	*8	*10				

Acceptability

SECURITY	STANDBY	ECO STANDBY	NO SIGNAL	SHUTTER	FREEZE	TEST PATTERN	REMOTE2	P IN P	LENS HOME
	✓		✓	✓		✓	✓	✓	

■ Note:

- It is only effective for DZ780(FDZ88C), other models return ER401.
- Character can be set numbers and decimal separator.
- Will be set to -40.0 to +40.0 in 0.2 increments.
(After activation of Geometry Manager Pro : -45.0 to +45.0 / 0.2 step)

3.72. GEOMETRY : KEYSTONE - HORIZONTAL KEYSTONE [VXX:GMKS9]

Hexadecimal	02h	41h	44h	5Ah	5Ah	3Bh	56h	58h	58h	3Ah
Character		A	D	Z	Z	;	V	X	X	:
Hexadecimal	47h	4Dh	4Bh	53h	39h	3Dh	*1	*3	*5	*7
Character	G	M	K	S	9	=	*2	*4	*6	*8
Hexadecimal	*9	03h								
Character	*10									

■ Parameters (*1,*2,*3,*4,*5,*6,*7,*8,*9,*10)

	-15.0					-14.8				
Hexadecimal	2Dh	31h	35h	2Eh	30h	2Dh	31h	34h	2Eh	38h
Character	-	1	5	.	0	-	1	4	.	8
	-9.8					+00.0				
Hexadecimal	2Dh	30h	39h	2Eh	38h	2Bh	30h	30h	2Eh	30h
Character	-	0	9	.	8	+	0	0	.	0
	+14.8					+15.0				
Hexadecimal	2Bh	31h	34h	2Eh	38h	2Bh	31H	35H	2Eh	30h
Character	+	1	4	.	8	+	1	5	.	0

■ Response (Callback)

In the period when the command can be accepted

Hexadecimal	02h	56h	58h	58h	3Ah	47h	4Dh	4Bh	53h	39h
Character		V	X	X	:	G	M	K	S	9
Hexadecimal	3Dh	*1	*3	*5	*7	*9	03h			
Character	=	*2	*4	*6	*8	*10				

Acceptability

SECURITY	STANDBY	ECO STANDBY	NO SIGNAL	SHUTTER	FREEZE	TEST PATTERN	REMOTE2	P IN P	LENS HOME
	✓		✓	✓		✓	✓	✓	

■ Note:

- It is only effective for DZ780(FDZ88C), other models return ER401.
- Character can be set numbers and decimal separator.
- Will be set to -15.0 to +15.0 in 0.2 increments.
(After activation of Geometry Manager Pro : -40.0 to +40.0 / 0.2 step)

3.73. GEOMETRY : CURVED - LENS THROW RATIO [VXX:GMCS0]

Hexadecimal	02h	41h	44h	5Ah	5Ah	3Bh	56h	58h	58h	3Ah
Character		A	D	Z	Z	;	V	X	X	:
Hexadecimal	47h	4Dh	43h	53h	30h	3Dh	2Bh	*1	*3	*5
Character	G	M	C	S	0	=	+	*2	*4	*6
Hexadecimal	*7	03h								
Character	*8									

■ Parameters (*1,*2,*3,*4,*5,*6,*7,*8)

	0.7				0.8					
Hexadecimal	30h	30h	2Eh	37h	30h	30h	2Eh	38h		
Character	0	0	.	7	0	0	.	8		
	16.4				16.5					
Hexadecimal	31h	36h	2Eh	34h	31h	36h	2Eh	35h		
Character	1	6	.	4	1	6	.	5		

■ Response (Callback)

In the period when the command can be accepted

Hexadecimal	02h	56h	58h	58h	3Ah	47h	4Dh	43h	53h	30h
Character		V	X	X	:	G	M	C	S	0
Hexadecimal	3Dh	2Bh	*1	*3	*5	*7	03h			
Character	=	+	*2	*4	*6	*8				

Acceptability

SECURITY	STANDBY	ECO STANDBY	NO SIGNAL	SHUTTER	FREEZE	TEST PATTERN	REMOTE2	P IN P	LENS HOME
	✓		✓	✓		✓	✓	✓	

■ Note:

- It is only effective for DZ780(FDZ88C), other models return ER401.
- Character can be set numbers and decimal separator.
- Will be set to 0.7 to 16.5 in 0.1 increments.

3.74. GEOMETRY : CURVED - VERTICAL ARC [VXX:GMC13]

Hexadecimal	02h	41h	44h	5Ah	5Ah	3Bh	56h	58h	58h	3Ah
Character		A	D	Z	Z	;	V	X	X	:
Hexadecimal	47h	4Dh	43h	49h	33h	3Dh	*1	*3	*5	*7
Character	G	M	C	l	3	=	*2	*4	*6	*8
Hexadecimal	*9	*11	03h							
Character	*10	*12								

■ Parameters (*1,*2,*3,*4,*5,*6,*7,*8,*9,*10,*11,*12)

	-50						-49					
Hexadecimal	2Dh	30h	30h	30h	35h	30h	2Dh	30h	30h	30h	34h	39h
Character	—	0	0	0	5	0	—	0	0	0	4	9
	+49						+50					
Hexadecimal	2Bh	30h	30h	30h	34h	39h	2Bh	30h	30h	30h	35h	30h
Character	+	0	0	0	4	9	+	0	0	0	5	0

■ Response (Callback)

In the period when the command can be accepted

Hexadecimal	02h	56h	58h	58h	3Ah	47h	4Dh	43h	49h	33h
Character		V	X	X	:	G	M	C	l	3
Hexadecimal	3Dh	*1	*3	*5	*7	*9	*11	03h		
Character	=	*2	*4	*6	*8	*10	*12			

Acceptability

SECURITY	STANDBY	ECO STANDBY	NO SIGNAL	SHUTTER	FREEZE	TEST PATTERN	REMOTE2	P IN P	LENS HOME
	✓		✓	✓		✓	✓	✓	

■ Note:

- It is only effective for DZ780(FDZ88C), other models return ER401.
- Will be set to -50 to +50. (After activation of Geometry Manager Pro: -100 to +100)

3.75. GEOMETRY : CURVED - HORIZONTAL ARC [VXX:GMC17]

Hexadecimal	02h	41h	44h	5Ah	5Ah	3Bh	56h	58h	58h	3Ah
Character		A	D	Z	Z	;	V	X	X	:
Hexadecimal	47h	4Dh	43h	49h	37h	3Dh	*1	*3	*5	*7
Character	G	M	C	l	7	=	*2	*4	*6	*8
Hexadecimal	*9	*11	03h							
Character	*10	*12								

■ Parameters (*1,*2,*3,*4,*5,*6,*7,*8,*9,*10,*11,*12)

	-50						-49					
Hexadecimal	2Dh	30h	30h	30h	35h	30h	2Dh	30h	30h	30h	34h	39h
Character	—	0	0	0	5	0	—	0	0	0	4	9
	+49						+50					
Hexadecimal	2Bh	30h	30h	30h	34h	39h	2Bh	30h	30h	30h	35h	30h
Character	+	0	0	0	4	9	+	0	0	0	5	0

■ Response (Callback)

In the period when the command can be accepted

Hexadecimal	02h	56h	58h	58h	3Ah	47h	4Dh	43h	49h	37h
Character		V	X	X	:	G	M	C	l	7
Hexadecimal	3Dh	*1	*3	*5	*7	*9	*11	03h		
Character	=	*2	*4	*6	*8	*10	*12			

Acceptability

SECURITY	STANDBY	ECO STANDBY	NO SIGNAL	SHUTTER	FREEZE	TEST PATTERN	REMOTE2	P IN P	LENS HOME
	✓		✓	✓		✓	✓	✓	

■ Note:

- It is only effective for DZ780(FDZ88C), other models return ER401.
- Will be set to -50 to +50. (After activation of Geometry Manager Pro: -100 to +100)

3.76. GEOMETRY : CURVED - VERTICAL BALANCE [VXX:GMCI2]

Hexadecimal	02h	41h	44h	5Ah	5Ah	3Bh	56h	58h	58h	3Ah
Character		A	D	Z	Z	;	V	X	X	:
Hexadecimal	47h	4Dh	43h	49h	32h	3Dh	*1	*3	*5	*7
Character	G	M	C	l	2	=	*2	*4	*6	*8
Hexadecimal	*9	*11	03h							
Character	*10	*12								

■ Parameters (*1,*2,*3,*4,*5,*6,*7,*8,*9,*10,*11,*12)

	-60						-59					
Hexadecimal	2Dh	30h	30h	30h	36h	30h	2Dh	30h	30h	30h	35h	39h
Character	—	0	0	0	6	0	—	0	0	0	5	9
	+59						+60					
Hexadecimal	2Bh	30h	30h	30h	35h	39h	2Bh	30h	30h	30h	36h	30h
Character	+	0	0	0	5	9	+	0	0	0	6	0

■ Response (Callback)

In the period when the command can be accepted

Hexadecimal	02h	56h	58h	58h	3Ah	47h	4Dh	43h	49h	32h
Character		V	X	X	:	G	M	C	l	2
Hexadecimal	3Dh	*1	*3	*5	*7	*9	*11	03h		
Character	=	*2	*4	*6	*8	*10	*12			

Acceptability

SECURITY	STANDBY	ECO STANDBY	NO SIGNAL	SHUTTER	FREEZE	TEST PATTERN	REMOTE2	P IN P	LENS HOME
	✓		✓	✓		✓	✓	✓	

■ Note:

· It is only effective for DZ780(FDZ88C), other models return ER401.

3.77. GEOMETRY : CURVED - HORIZONTAL BALANCE [VXX:GMCI6]

Hexadecimal	02h	41h	44h	5Ah	5Ah	3Bh	56h	58h	58h	3Ah
Character		A	D	Z	Z	;	V	X	X	:
Hexadecimal	47h	4Dh	43h	49h	36h	3Dh	*1	*3	*5	*7
Character	G	M	C	l	6	=	*2	*4	*6	*8
Hexadecimal	*9	*11	03h							
Character	*10	*12								

■ Parameters (*1,*2,*3,*4,*5,*6,*7,*8,*9,*10,*11,*12)

	-30						-29					
Hexadecimal	2Dh	30h	30h	30h	33h	30h	2Dh	30h	30h	30h	32h	39h
Character	—	0	0	0	3	0	—	0	0	0	2	9
	+29						+30					
Hexadecimal	2Bh	30h	30h	30h	32h	39h	2Bh	30h	30h	30h	33h	30h
Character	+	0	0	0	2	9	+	0	0	0	3	0

■ Response (Callback)

In the period when the command can be accepted

Hexadecimal	02h	56h	58h	58h	3Ah	47h	4Dh	43h	49h	36h
Character		V	X	X	:	G	M	C	l	6
Hexadecimal	3Dh	*1	*3	*5	*7	*9	*11	03h		
Character	=	*2	*4	*6	*8	*10	*12			

Acceptability

SECURITY	STANDBY	ECO STANDBY	NO SIGNAL	SHUTTER	FREEZE	TEST PATTERN	REMOTE2	P IN P	LENS HOME
	✓		✓	✓		✓	✓	✓	

■ Note:

· It is only effective for DZ780(FDZ88C), other models return ER401.

3.78. GEOMETRY : CURVED - VERTICAL KEYSTONE [VXX:GMCS8]

Hexadecimal	02h	41h	44h	5Ah	5Ah	3Bh	56h	58h	58h	3Ah
Character		A	D	Z	Z	;	V	X	X	:
Hexadecimal	47h	4Dh	43h	53h	38h	3Dh	*1	*3	*5	*7
Character	G	M	C	S	8	=	*2	*4	*6	*8
Hexadecimal	*9	03h								
Character	*10									

■ Parameters (*1,*2,*3,*4,*5,*6,*7,*8,*9,*10)

	-40.0					-38.8				
Hexadecimal	2Dh	34h	30h	2Eh	30h	2Dh	33h	38h	2Eh	38h
Character	-	4	0	.	0	-	3	8	.	8
	-9.8					+00.0				
Hexadecimal	2Dh	30h	39h	2Eh	38h	2Bh	30h	30h	2Eh	30h
Character	-	0	9	.	8	+	0	0	.	0
	+38.8					+40.0				
Hexadecimal	2Bh	33h	38h	2Eh	38h	2Bh	34h	30h	2Eh	30h
Character	+	3	8	.	8	+	4	0	.	0

■ Response (Callback)

In the period when the command can be accepted

Hexadecimal	02h	56h	58h	58h	3Ah	47h	4Dh	43h	53h	38h
Character		V	X	X	:	G	M	C	S	8
Hexadecimal	3Dh	*1	*3	*5	*7	*9	03h			
Character	=	*2	*4	*6	*8	*10				

Acceptability

SECURITY	STANDBY	ECO STANDBY	NO SIGNAL	SHUTTER	FREEZE	TEST PATTERN	REMOTE2	P IN P	LENS HOME
	✓		✓	✓		✓	✓	✓	

■ Note:

- It is only effective for DZ780(FDZ88C), other models return ER401.
- Character can be set numbers and decimal separator.
- Will be set to -40.0 to +40.0 in 0.2 increments. (After activation of Geometry Manager Pro: -45.0 to +45.0 / 0.2 step)

3.79. GEOMETRY : CURVED - HORIZONTAL KEYSTONE [VXX:GMCS9]

Hexadecimal	02h	41h	44h	5Ah	5Ah	3Bh	56h	58h	58h	3Ah
Character		A	D	Z	Z	;	V	X	X	:
Hexadecimal	47h	4Dh	43h	53h	39h	3Dh	*1	*3	*5	*7
Character	G	M	C	S	9	=	*2	*4	*6	*8
Hexadecimal	*9	03h								
Character	*10									

■ Parameters (*1,*2,*3,*4,*5,*6,*7,*8,*9,*10)

	-15.0					-14.8				
Hexadecimal	2Dh	31h	35h	2Eh	30h	2Dh	31h	34h	2Eh	38h
Character	-	1	5	.	0	-	1	4	.	8
	-9.8					+0.0				
Hexadecimal	2Dh	30h	39h	2Eh	38h	2Bh	30h	30h	2Eh	30h
Character	-	0	9	.	8	+	0	0	.	0
	+14.8					+15.0				
Hexadecimal	2Bh	33h	38h	2Eh	38h	2Bh	31h	35h	2Eh	30h
Character	+	1	4	.	8	+	1	5	.	0

■ Response (Callback)

In the period when the command can be accepted

Hexadecimal	02h	56h	58h	58h	3Ah	47h	4Dh	43h	53h	39h
Character		V	X	X	:	G	M	C	S	9
Hexadecimal	3Dh	*1	*3	*5	*7	*9	03h			
Character	=	*2	*4	*6	*8	*10				

Acceptability

SECURITY	STANDBY	ECO STANDBY	NO SIGNAL	SHUTTER	FREEZE	TEST PATTERN	REMOTE2	P IN P	LENS HOME
	✓		✓	✓		✓	✓	✓	

■ Note:

- It is only effective for DZ780(FDZ88C), other models return ER401.
- Character can be set numbers and decimal separator.
- Will be set to -15.0 to +15.0 in 0.2 increments. (After activation of Geometry Manager Pro: -40.0 to +40.0 / 0.2 step)

3.80. GEOMETRY : CURVED - MAINTAIN ASPECT RATIO [VXX:GMCIA]

Hexadecimal	02h	41h	44h	5Ah	5Ah	3Bh	56h	58h	58h	3Ah
Character		A	D	Z	Z	;	V	X	X	:
Hexadecimal	47h	4Dh	43h	49h	41h	3Dh	2Bh	*1	*3	*5
Character	G	M	C	I	A	=	+	*2	*4	*6
Hexadecimal	*7	*9	03h							
Character	*8	*10								

■ Parameters (*1,*2,*3,*4,*5,*6,*7,*8,*9,*10)

	OFF					ON				
Hexadecimal	30h	30h	30h	30h	30h	30h	30h	30h	30h	31h
Character	0	0	0	0	0	0	0	0	0	1

■ Response (Callback)

In the period when the command can be accepted

Hexadecimal	02h	56h	58h	58h	3Ah	47h	4Dh	43h	49h	41h
Character		V	X	X	:	G	M	C	I	A
Hexadecimal	3Dh	2Bh	*1	*3	*5	*7	*9	03h		
Character	=	+	*2	*4	*6	*8	*10			

Acceptability

SECURITY	STANDBY	ECO STANDBY	NO SIGNAL	SHUTTER	FREEZE	TEST PATTERN	REMOTE2	P IN P	LENS HOME
	✓		✓	✓		✓	✓	✓	

■ Note:

- It is only effective for DZ780(FDZ88C), other models return ER401.

3.81. GEOMETRY : CORNER CORRECTION - UPPER LEFT - VERTICAL [VXX:GMFI1]

Hexadecimal	02h	41h	44h	5Ah	5Ah	3Bh	56h	58h	58h	3Ah
Character		A	D	Z	Z	;	V	X	X	:
Hexadecimal	47h	4Dh	46h	49h	31h	3Dh	*1	*3	*5	*7
Character	G	M	F	l	1	=	*2	*4	*6	*8
Hexadecimal	*9	*11	03h							
Character	*10	*12								

■ Parameters (*1,*2,*3,*4,*5,*6,*7,*8,*9,*10,*11,*12)

	+0						+300					
Hexadecimal	2Bh	30h	30h	30h	30h	30h	2Bh	30h	30h	33h	30h	30h
Character	+	0	0	0	0	0	+	0	0	3	0	0

■ Response (Callback)

In the period when the command can be accepted

Hexadecimal	02h	56h	58h	58h	3Ah	47h	4Dh	46h	49h	31h
Character		V	X	X	:	G	M	F	l	1
Hexadecimal	3Dh	*1	*3	*5	*7	*9	*11	03h		
Character	=	*2	*4	*6	*8	*10	*12			

Acceptability

SECURITY	STANDBY	ECO STANDBY	NO SIGNAL	SHUTTER	FREEZE	TEST PATTERN	REMOTE2	P IN P	LENS HOME
	✓		✓	✓		✓	✓	✓	

■ Note:

· It is only effective for DZ780(FDZ88C), other models return ER401.

3.82. GEOMETRY : CORNER CORRECTION - UPPER RIGHT - VERTICAL [VXX:GMFI2]

Hexadecimal	02h	41h	44h	5Ah	5Ah	3Bh	56h	58h	58h	3Ah
Character		A	D	Z	Z	;	V	X	X	:
Hexadecimal	47h	4Dh	46h	49h	32h	3Dh	*1	*3	*5	*7
Character	G	M	F	l	2	=	*2	*4	*6	*8
Hexadecimal	*9	*11	03h							
Character	*10	*12								

■ Parameters (*1,*2,*3,*4,*5,*6,*7,*8,*9,*10,*11,*12)

	+0						+300					
Hexadecimal	2Bh	30h	30h	30h	30h	30h	2Bh	30h	30h	33h	30h	30h
Character	+	0	0	0	0	0	+	0	0	3	0	0

■ Response (Callback)

In the period when the command can be accepted

Hexadecimal	02h	56h	58h	58h	3Ah	47h	4Dh	46h	49h	31h
Character		V	X	X	:	G	M	F	l	2
Hexadecimal	3Dh	*1	*3	*5	*7	*9	*11	03h		
Character	=	*2	*4	*6	*8	*10	*12			

Acceptability

SECURITY	STANDBY	ECO STANDBY	NO SIGNAL	SHUTTER	FREEZE	TEST PATTERN	REMOTE2	P IN P	LENS HOME
	✓		✓	✓		✓	✓	✓	

■ Note:

· It is only effective for DZ780(FDZ88C), other models return ER401.

3.83. GEOMETRY : CORNER CORRECTION - LOWER LEFT - VERTICAL [VXX:GMFI3]

Hexadecimal	02h	41h	44h	5Ah	5Ah	3Bh	56h	58h	58h	3Ah
Character		A	D	Z	Z	;	V	X	X	:
Hexadecimal	47h	4Dh	46h	49h	33h	3Dh	*1	*3	*5	*7
Character	G	M	F	l	3	=	*2	*4	*6	*8
Hexadecimal	*9	*11	03h							
Character	*10	*12								

■ Parameters (*1,*2,*3,*4,*5,*6,*7,*8,*9,*10,*11,*12)

	-300						+0					
Hexadecimal	2Dh	30h	30h	30h	30h	30h	2Bh	30h	30h	30h	30h	30h
Character	—	0	0	0	0	0	+	0	0	0	0	0

■ Response (Callback)

In the period when the command can be accepted

Hexadecimal	02h	56h	58h	58h	3Ah	47h	4Dh	46h	49h	33h
Character		V	X	X	:	G	M	F	l	3
Hexadecimal	3Dh	*1	*3	*5	*7	*9	*11	03h		
Character	=	*2	*4	*6	*8	*10	*12			

Acceptability

SECURITY	STANDBY	ECO STANDBY	NO SIGNAL	SHUTTER	FREEZE	TEST PATTERN	REMOTE2	P IN P	LENS HOME
	✓		✓	✓		✓	✓	✓	

■ Note:

· It is only effective for DZ780(FDZ88C), other models return ER401.

3.84. GEOMETRY : CORNER CORRECTION - LOWER RIGHT - VERTICAL [VXX:GMF14]

Hexadecimal	02h	41h	44h	5Ah	5Ah	3Bh	56h	58h	58h	3Ah
Character		A	D	Z	Z	;	V	X	X	:
Hexadecimal	47h	4Dh	46h	49h	34h	3Dh	*1	*3	*5	*7
Character	G	M	F	l	4	=	*2	*4	*6	*8
Hexadecimal	*9	*11	03h							
Character	*10	*12								

■ Parameters (*1,*2,*3,*4,*5,*6,*7,*8,*9,*10,*11,*12)

	-300						+0					
Hexadecimal	2Dh	30h	30h	33h	30h	30h	2Bh	30h	30h	30h	30h	30h
Character	—	0	0	3	0	0	+	0	0	0	0	0

■ Response (Callback)

In the period when the command can be accepted

Hexadecimal	02h	56h	58h	58h	3Ah	47h	4Dh	46h	49h	34h
Character		V	X	X	:	G	M	F	l	4
Hexadecimal	3Dh	*1	*3	*5	*7	*9	*11	03h		
Character	=	*2	*4	*6	*8	*10	*12			

Acceptability

SECURITY	STANDBY	ECO STANDBY	NO SIGNAL	SHUTTER	FREEZE	TEST PATTERN	REMOTE2	P IN P	LENS HOME
	✓		✓	✓		✓	✓	✓	

■ Note:

· It is only effective for DZ780(FDZ88C), other models return ER401.

3.85. GEOMETRY : CORNER CORRECTION - LINEARITY - VERTICAL [VXX:GMF15]

Hexadecimal	02h	41h	44h	5Ah	5Ah	3Bh	56h	58h	58h	3Ah
Character		A	D	Z	Z	;	V	X	X	:
Hexadecimal	47h	4Dh	46h	49h	35h	3Dh	*1	*3	*5	*7
Character	G	M	F	l	5	=	*2	*4	*6	*8
Hexadecimal	*9	*11	03h							
Character	*10	*12								

■ Parameters (*1,*2,*3,*4,*5,*6,*7,*8,*9,*10,*11,*12)

	-127						+128					
Hexadecimal	2Dh	30h	30h	31h	32h	37h	2Bh	30h	30h	31h	32h	37h
Character	—	0	0	1	2	7	+	0	0	1	2	7

■ Response (Callback)

In the period when the command can be accepted

Hexadecimal	02h	56h	58h	58h	3Ah	47h	4Dh	46h	49h	35h
Character		V	X	X	:	G	M	F	l	5
Hexadecimal	3Dh	*1	*3	*5	*7	*9	*11	03h		
Character	=	*2	*4	*6	*8	*10	*12			

Acceptability

SECURITY	STANDBY	ECO STANDBY	NO SIGNAL	SHUTTER	FREEZE	TEST PATTERN	REMOTE2	P IN P	LENS HOME
	✓		✓	✓		✓	✓	✓	

■ Note:

· It is only effective for DZ780(FDZ88C), other models return ER401.

3.86. GEOMETRY : CORNER CORRECTION - UPPER LEFT - HORIZONTAL [VXX:GMF16]

Hexadecimal	02h	41h	44h	5Ah	5Ah	3Bh	56h	58h	58h	3Ah
Character		A	D	Z	Z	;	V	X	X	:
Hexadecimal	47h	4Dh	46h	49h	36h	3Dh	*1	*3	*5	*7
Character	G	M	F	l	6	=	*2	*4	*6	*8
Hexadecimal	*9	*11	03h							
Character	*10	*12								

■ Parameters (*1,*2,*3,*4,*5,*6,*7,*8,*9,*10,*11,*12)

	+0						+480					
Hexadecimal	2Bh	30h	30h	30h	30h	30h	2Bh	30h	30h	34h	38h	30h
Character	+	0	0	0	0	0	+	0	0	4	8	0

■ Response (Callback)

In the period when the command can be accepted

Hexadecimal	02h	56h	58h	58h	3Ah	47h	4Dh	46h	49h	36h
Character		V	X	X	:	G	M	F	l	6
Hexadecimal	3Dh	*1	*3	*5	*7	*9	*11	03h		
Character	=	*2	*4	*6	*8	*10	*12			

Acceptability

SECURITY	STANDBY	ECO STANDBY	NO SIGNAL	SHUTTER	FREEZE	TEST PATTERN	REMOTE2	P IN P	LENS HOME
	✓		✓	✓		✓	✓	✓	

■ Note:

· It is only effective for DZ780(FDZ88C), other models return ER401.

3.87. GEOMETRY : CORNER CORRECTION - UPPER RIGHT - HORIZONTAL [VXX:GMF17]

Hexadecimal	02h	41h	44h	5Ah	5Ah	3Bh	56h	58h	58h	3Ah
Character		A	D	Z	Z	;	V	X	X	:
Hexadecimal	47h	4Dh	46h	49h	37h	3Dh	*1	*3	*5	*7
Character	G	M	F	l	7	=	*2	*4	*6	*8
Hexadecimal	*9	*11	03h							
Character	*10	*12								

■ Parameters (*1,*2,*3,*4,*5,*6,*7,*8,*9,*10,*11,*12)

	-480						+0					
Hexadecimal	2Dh	30h	30h	34h	38h	30h	2Bh	30h	30h	30h	30h	30h
Character	—	0	0	4	8	0	+	0	0	0	0	0

■ Response (Callback)

In the period when the command can be accepted

Hexadecimal	02h	56h	58h	58h	3Ah	47h	4Dh	46h	49h	37h
Character		V	X	X	:	G	M	F	l	7
Hexadecimal	3Dh	*1	*3	*5	*7	*9	*11	03h		
Character	=	*2	*4	*6	*8	*10	*12			

Acceptability

SECURITY	STANDBY	ECO STANDBY	NO SIGNAL	SHUTTER	FREEZE	TEST PATTERN	REMOTE2	P IN P	LENS HOME
	✓		✓	✓		✓	✓	✓	

■ Note:

· It is only effective for DZ780(FDZ88C), other models return ER401.

3.88. GEOMETRY : CORNER CORRECTION - LOWER LEFT - HORIZONTAL [VXX:GMF18]

Hexadecimal	02h	41h	44h	5Ah	5Ah	3Bh	56h	58h	58h	3Ah
Character		A	D	Z	Z	;	V	X	X	:
Hexadecimal	47h	4Dh	46h	49h	38h	3Dh	*1	*3	*5	*7
Character	G	M	F	l	8	=	*2	*4	*6	*8
Hexadecimal	*9	*11	03h							
Character	*10	*12								

■ Parameters (*1,*2,*3,*4,*5,*6,*7,*8,*9,*10,*11,*12)

	+0						+480					
Hexadecimal	2Bh	30h	30h	30h	30h	30h	2Bh	30h	30h	34h	38h	30h
Character	+	0	0	0	0	0	+	0	0	4	8	0

■ Response (Callback)

In the period when the command can be accepted

Hexadecimal	02h	56h	58h	58h	3Ah	47h	4Dh	46h	49h	38h
Character		V	X	X	:	G	M	F	l	8
Hexadecimal	3Dh	*1	*3	*5	*7	*9	*11	03h		
Character	=	*2	*4	*6	*8	*10	*12			

Acceptability

SECURITY	STANDBY	ECO STANDBY	NO SIGNAL	SHUTTER	FREEZE	TEST PATTERN	REMOTE2	P IN P	LENS HOME
	✓		✓	✓		✓	✓	✓	

■ Note:

· It is only effective for DZ780(FDZ88C), other models return ER401.

3.89. GEOMETRY : CORNER CORRECTION - LOWER RIGHT - HORIZONTAL [VXX:GMF19]

Hexadecimal	02h	41h	44h	5Ah	5Ah	3Bh	56h	58h	58h	3Ah
Character		A	D	Z	Z	;	V	X	X	:
Hexadecimal	47h	4Dh	46h	49h	39h	3Dh	*1	*3	*5	*7
Character	G	M	F	l	9	=	*2	*4	*6	*8
Hexadecimal	*9	*11	03h							
Character	*10	*12								

■ Parameters (*1,*2,*3,*4,*5,*6,*7,*8,*9,*10,*11,*12)

	-480						+0					
Hexadecimal	2Dh	30h	30h	34h	38h	30h	2Bh	30h	30h	30h	30h	30h
Character	—	0	0	4	8	0	+	0	0	0	0	0

■ Response (Callback)

In the period when the command can be accepted

Hexadecimal	02h	56h	58h	58h	3Ah	47h	4Dh	46h	49h	39h
Character		V	X	X	:	G	M	F	l	9
Hexadecimal	3Dh	*1	*3	*5	*7	*9	*11	03h		
Character	=	*2	*4	*6	*8	*10	*12			

Acceptability

SECURITY	STANDBY	ECO STANDBY	NO SIGNAL	SHUTTER	FREEZE	TEST PATTERN	REMOTE2	P IN P	LENS HOME
	✓		✓	✓		✓	✓	✓	

■ Note:

· It is only effective for DZ780(FDZ88C), other models return ER401.

3.90. GEOMETRY : CORNER CORRECTION - LINEARITY - HORIZONTAL [VXX:GMFIA]

Hexadecimal	02h	41h	44h	5Ah	5Ah	3Bh	56h	58h	58h	3Ah
Character		A	D	Z	Z	:	V	X	X	:
Hexadecimal	47h	4Dh	46h	49h	38h	3Dh	*1	*3	*5	*7
Character	G	M	F	I	8	=	*2	*4	*6	*8
Hexadecimal	*9	*11	03h							
Character	*10	*12								

■ Parameters (*1,*2,*3,*4,*5,*6,*7,*8,*9,*10,*11,*12)

	-127						+127					
Hexadecimal	2Dh	30h	30h	31h	32h	37h	2Bh	30h	30h	31h	32h	37h
Character	—	0	0	1	2	7	+	0	0	1	2	7

■ Response (Callback)

In the period when the command can be accepted

Hexadecimal	02h	56h	58h	58h	3Ah	47h	4Dh	46h	49h	41h
Character		V	X	X	:	G	M	F	I	A
Hexadecimal	3Dh	*1	*3	*5	*7	*9	*11	03h		
Character	=	*2	*4	*6	*8	*10	*12			

Acceptability

SECURITY	STANDBY	ECO STANDBY	NO SIGNAL	SHUTTER	FREEZE	TEST PATTERN	REMOTE2	P IN P	LENS HOME
	✓		✓	✓		✓	✓	✓	

■ Note:

· It is only effective for DZ780(FDZ88C), other models return ER401.

3.91. DIGITAL CINEMA REALITY [OPD]

Hexadecimal	02h	41h	44h	5Ah	5Ah	3Bh	4Fh	50h	44h	3Ah
Character		A	D	Z	Z	:	O	P	D	:
Hexadecimal	*1	03h								
Character	*2									

■ Parameters (*1,*2)

	AUTO		OFF		30p/25p FIXED	
Hexadecimal	30h		31h		32h	
Character	0		1		2	

■ Response (Callback)

In the period when the command can be accepted

Hexadecimal	02h	4Fh	50h	44h	3Ah	*1	03h
Character		O	P	D	:	*2	

Acceptability

SECURITY	STANDBY	ECO STANDBY	NO SIGNAL	SHUTTER	FREEZE	TEST PATTERN	REMOTE2	P IN P	LENS HOME
				✓		✓	✓	✓	

3.92. BLANKING - UPPER [DBU]

Hexadecimal	02h	41h	44h	5Ah	5Ah	3Bh	44h	42h	55h	3Ah
Character		A	D	Z	Z	:	D	B	U	:
Hexadecimal	*1	*3	*5	03h						
Character	*2	*4	*6							

■ Parameters (*1,*2,*3,*4,*5,*6)

	0			1			2		
Hexadecimal	30h	30h	30h	30h	30h	31h	30h	30h	32h
Character	0	0	0	0	0	1	0	0	2

DZ780 (FDZ88C)

	597			598			599		
Hexadecimal	35h	39h	37h	35h	39h	37h	35h	39h	37h
Character	5	9	7	5	9	7	5	9	7

DW750 (FDW85C)

	397			398			399		
Hexadecimal	35h	32h	32h	35h	32h	33h	35h	32h	34h
Character	3	9	7	3	9	8	3	9	9

DX820 (FDX92C, FDX605C)

	381			382			383		
Hexadecimal	33h	38h	31h	33h	38h	32h	33h	38h	33h
Character	3	8	1	3	8	2	3	8	3

■ Note:

· Maximum value will change by input signal or aspect, zoom setting conditions.

■ Response (Callback)

In the period when the command can be accepted

Hexadecimal	02h	44h	42h	55h	3Ah	*1	*3	*5	03h
Character		D	B	U	:	*2	*4	*6	

Acceptability

SECURITY	STANDBY	ECO STANDBY	NO SIGNAL	SHUTTER	FREEZE	TEST PATTERN	REMOTE2	P IN P	LENS HOME
				✓		✓	✓	✓	

3.93. BLANKING - LOWER [DBB]

Hexadecimal	02h	41h	44h	5Ah	5Ah	3Bh	44h	42h	42h	3Ah
Character		A	D	Z	Z	;	D	B	B	:
Hexadecimal	*1	*3	*5	03h						
Character	*2	*4	*6							

■ Parameters (*1,*2,*3,*4,*5,*6)

	0			1			2		
Hexadecimal	30h	30h	30h	30h	30h	31h	30h	30h	32h
Character	0	0	0	0	0	1	0	0	2

DZ780 (FDZ88C)

	597			598			599		
Hexadecimal	35h	39h	37h	35h	39h	37h	35h	39h	37h
Character	5	9	7	5	9	7	5	9	7

DW750 (FDW85C)

	397			398			399		
Hexadecimal	35h	32h	32h	35h	32h	32h	35h	32h	32h
Character	3	9	7	3	9	7	3	9	7

DX820 (FDX92C, FDX605C)

	381			382			383		
Hexadecimal	33h	38h	31h	33h	38h	31h	33h	38h	31h
Character	3	8	1	3	8	1	3	8	1

■ Note:

· Maximum value will change by input signal or aspect, zoom setting conditions.

■ Response (Callback)

In the period when the command can be accepted

Hexadecimal	02h	44h	42h	42h	3Ah	*1	*3	*5	03h
Character		D	B	B	:	*2	*4	*6	

Acceptability

SECURITY	STANDBY	ECO STANDBY	NO SIGNAL	SHUTTER	FREEZE	TEST PATTERN	REMOTE2	P IN P	LENS HOME
				✓		✓	✓	✓	

3.94. BLANKING - RIGHT [DBR]

Hexadecimal	02h	41h	44h	5Ah	5Ah	3Bh	44h	42h	52h	3Ah
Character		A	D	Z	Z	;	D	B	R	:
Hexadecimal	*1	*3	*5	03h						
Character	*2	*4	*6							

■ Parameters (*1,*2,*3,*4,*5,*6)

	0			1			2		
Hexadecimal	30h	30h	30h	30h	30h	31h	30h	30h	32h
Character	0	0	0	0	0	1	0	0	2

DZ780 (FDZ88C)

	957			958			959		
Hexadecimal	39h	35h	37h	39h	35h	38h	39h	35h	39h
Character	9	5	7	9	5	8	9	5	9

DW750 (FDW85C)

	637			638			639		
Hexadecimal	36h	39h	37h	36h	39h	38h	36h	39h	39h
Character	6	3	7	6	3	8	6	3	9

DX820 (FDX92C, FDX605C)

	509			510			511		
Hexadecimal	36h	38h	30h	36h	38h	31h	36h	38h	32h
Character	5	0	9	5	1	0	5	1	1

■ Note:

· Maximum value will change by input signal or aspect, zoom setting conditions.

■ Response (Callback)

In the period when the command can be accepted

Hexadecimal	02h	44h	42h	52h	3Ah	*1	*3	*5	03h
Character		D	B	R	:	*2	*4	*6	

Acceptability

SECURITY	STANDBY	ECO STANDBY	NO SIGNAL	SHUTTER	FREEZE	TEST PATTERN	REMOTE2	P IN P	LENS HOME
				✓		✓	✓	✓	

3.95. BLANKING - LEFT [DBL]

Hexadecimal	02h	41h	44h	5Ah	5Ah	3Bh	44h	42h	4Ch	3Ah
Character		A	D	Z	Z	;	D	B	L	:
Hexadecimal	*1	*3	*5	03h						
Character	*2	*4	*6							

■ Parameters (*1,*2,*3,*4,*5,*6)

	0			1			2		
Hexadecimal	30h	30h	30h	30h	30h	31h	30h	30h	32h
Character	0	0	0	0	0	1	0	0	2

DZ780 (FDZ88C)

	957			958			959		
Hexadecimal	39h	35h	37h	39h	35h	38h	39h	35h	39h
Character	9	5	7	9	5	8	9	5	9

DW750 (FDW85C)

	637			638			639		
Hexadecimal	36h	39h	37h	36h	39h	38h	36h	39h	39h
Character	6	3	7	6	3	8	6	3	9

DX820 (FDX92C, FDX605C)

	509			510			511		
Hexadecimal	36h	38h	30h	36h	38h	31h	36h	38h	32h
Character	5	0	9	5	1	0	5	1	1

■ Note:

· Maximum value will change by input signal or aspect, zoom setting conditions.

■ Response (Callback)

In the period when the command can be accepted

Hexadecimal	02h	44h	42h	4Ch	3Ah	*1	*3	*5	03h
Character		D	B	L	:	*2	*4	*6	

Acceptability

SECURITY	STANDBY	ECO STANDBY	NO SIGNAL	SHUTTER	FREEZE	TEST PATTERN	REMOTE2	P IN P	LENS HOME
				✓		✓	✓	✓	

3.96. MASKING MODE [VXX:MSKI1]

Hexadecimal	02h	41h	44h	5Ah	5Ah	3Bh	56h	58h	58h	3Ah
Character		A	D	Z	Z	;	V	X	X	:
Hexadecimal	4Dh	53h	4Bh	49h	31h	3Dh	2Bh	*1	*3	*5
Character	M	S	K	l	1	=	+	*2	*4	*6
Hexadecimal	*7	*9	03h							
Character	*8	*10								

■ Parameters (*1,*2,*3,*4,*5,*6,*7,*8,*9,*10)

	OFF					PC-1				
Hexadecimal	30h	30h	30h	30h	30h	30h	30h	30h	30h	31h
Character	0	0	0	0	0	0	0	0	0	1
	PC-2					PC-3				
Hexadecimal	30h	30h	30h	30h	32h	30h	30h	30h	30h	33h
Character	0	0	0	0	2	0	0	0	0	3

■ Response (Callback)

In the period when the command can be accepted

Hexadecimal	02h	56h	58h	58h	3Ah	4Dh	53h	4Bh	49h	31h
Character		V	X	X	:	M	S	K	l	1
Hexadecimal	3Dh	2Bh	*1	*3	*5	*7	*9	03h		
Character	=	+	*2	*4	*6	*8	*10			

Acceptability

SECURITY	STANDBY	ECO STANDBY	NO SIGNAL	SHUTTER	FREEZE	TEST PATTERN	REMOTE2	P IN P	LENS HOME
			✓	✓		✓	✓	✓	

■ Note:

· It is only effective for DZ780(FDZ88C), other models return ER401.

· To use this function, an optional upgrade kit (activated) is required.

3.97. INPUT RESOLUTION - TOTAL DOTS [VTD]

Hexadecimal	02h	41h	44h	5Ah	5Ah	3Bh	56h	54h	44h	3Ah
Character		A	D	Z	Z	;	V	T	D	:
Hexadecimal	*1	*3	*5	*7	03h					
Character	*2	*4	*6	*8						

■ Parameters (*1,*2,*3,*4,*5,*6,*7,*8)

	330				331			
Hexadecimal	30h	33h	33h	30h	30h	33h	33h	31h
Character	0	3	3	0	0	3	3	1
	4094				4095			
Hexadecimal	34h	30h	39h	34h	34h	30h	39h	35h
Character	4	0	9	4	4	0	9	5

■ Response (Callback)

In the period when the command can be accepted

Hexadecimal	02h	56h	54h	44h	3Ah	*1	*3	*5	*7	03h
Character		V	T	D	:	*2	*4	*6	*8	

Acceptability

SECURITY	STANDBY	ECO STANDBY	NO SIGNAL	SHUTTER	FREEZE	TEST PATTERN	REMOTE2	P IN P	LENS HOME
				✓		✓	✓	✓	

■ Note:

- Adjustable maximum value varies according to the input resolution or set the input signal.
- When a parameter value is less than DISPLAY DOTS plus 30, will return ER402.
- It can be adjusted only when RGB signal or HV Sync motion picture are input to RGB1-IN terminal or RGB2-IN terminal.

3.98. INPUT RESOLUTION - DISPLAY DOTS [VDD]

Hexadecimal	02h	41h	44h	5Ah	5Ah	3Bh	56h	44h	44h	3Ah
Character		A	D	Z	Z	;	V	D	D	:
Hexadecimal	*1	*3	*5	*7	03h					
Character	*2	*4	*6	*8						

■ Parameters (*1,*2,*3,*4,*5,*6,*7,*8)

	300				301			
Hexadecimal	30h	33h	30h	30h	30h	33h	30h	31h
Character	0	3	0	0	0	3	0	1
	4064				4065			
Hexadecimal	34h	30h	36h	34h	34h	30h	36h	35h
Character	4	0	6	4	4	0	6	5

■ Response (Callback)

In the period when the command can be accepted

Hexadecimal	02h	56h	44h	44h	3Ah	*1	*3	*5	*7	03h
Character		V	D	D	:	*2	*4	*6	*8	

Acceptability

SECURITY	STANDBY	ECO STANDBY	NO SIGNAL	SHUTTER	FREEZE	TEST PATTERN	REMOTE2	P IN P	LENS HOME
				✓		✓	✓	✓	

■ Note:

- Enabled by RGB1 or RGB2 inputs.
- Adjustable maximum value varies according to the input resolution or set the input signal.
- When a parameter value is TOTAL DOTS -30 or more, will return ER402.

3.99. INPUT RESOLUTION - TOTAL LINES [VTL]

Hexadecimal	02h	41h	44h	5Ah	5Ah	3Bh	56h	54h	4Ch	3Ah
Character		A	D	Z	Z	;	V	T	L	:
Hexadecimal	*1	*3	*5	*7	03h					
Character	*2	*4	*6	*8						

■ Parameters (*1,*2,*3,*4,*5,*6,*7,*8)

	155				156			
Hexadecimal	30h	31h	35h	35h	30h	31h	35h	36h
Character	0	1	5	5	0	1	5	6
	2046				2047			
Hexadecimal	24h	30h	34h	36h	32h	30h	34h	37h
Character	2	0	4	6	2	0	4	7

■ Response (Callback)

In the period when the command can be accepted

Hexadecimal	02h	56h	54h	4Ch	3Ah	*1	*3	*5	*7	03h
Character		V	T	L	:	*2	*4	*6	*8	

Acceptability

SECURITY	STANDBY	ECO STANDBY	NO SIGNAL	SHUTTER	FREEZE	TEST PATTERN	REMOTE2	P IN P	LENS HOME
				✓		✓	✓	✓	

■ Note:

- Enabled by RGB1 or RGB2 inputs.
- Adjustable maximum value varies according to the input resolution or set the input signal.
- When a parameter value is less than DISPLAY LINES plus 10, will return ER402.

3.100. INPUT RESOLUTION - DISPLAY LINES [VDL]

Hexadecimal	02h	41h	44h	5Ah	5Ah	3Bh	56h	44h	4Ch	3Ah
Character		A	D	Z	Z	;	V	D	L	:
Hexadecimal	*1	*3	*5	*7	03h					
Character	*2	*4	*6	*8						

■ Parameters (*1,*2,*3,*4,*5,*6,*7,*8)

	150				151			
Hexadecimal	30h	31h	35h	30h	30h	31h	35h	31h
Character	0	1	5	0	0	1	5	1
	2036				2037			
Hexadecimal	32h	30h	33h	36h	32h	30h	33h	37h
Character	2	0	3	6	2	0	3	7

■ Response (Callback)

In the period when the command can be accepted

Hexadecimal	02h	56h	44h	4Ch	3Ah	*1	*3	*5	*7	03h
Character		V	D	L	:	*2	*4	*6	*8	

Acceptability

SECURITY	STANDBY	ECO STANDBY	NO SIGNAL	SHUTTER	FREEZE	TEST PATTERN	REMOTE2	P IN P	LENS HOME
				✓		✓	✓	✓	

■ Note:

- Enabled by RGB1 or RGB2 inputs.
- Adjustable maximum value varies according to the input resolution or set the input signal.
- When a parameter value is TOTAL LINES -10 or more, will return ER402.

3.101. CLAMP POSITION [VLT]

Hexadecimal	02h	41h	44h	5Ah	5Ah	3Bh	56h	4Ch	54h	3Ah
Character		A	D	Z	Z	;	V	L	T	:
Hexadecimal	*1	*3	*5	03h						
Character	*2	*4	*6							

■ Parameters (*1,*2,*3,*4,*5,*6)

	1			2		
Hexadecimal	30h	30h	31h	30h	30h	32h
Character	0	0	1	0	0	2
	254			255		
Hexadecimal	32h	35h	34h	32h	35h	35h
Character	2	5	4	2	5	5

■ Response (Callback)

In the period when the command can be accepted

Hexadecimal	02h	56h	4Ch	54h	3Ah	*1	*3	*5	03h
Character		V	L	T	:	*2	*4	*6	

Acceptability

SECURITY	STANDBY	ECO STANDBY	NO SIGNAL	SHUTTER	FREEZE	TEST PATTERN	REMOTE2	P IN P	LENS HOME
				✓		✓	✓	✓	

■ Note:

- This command is available only when RGB1 or RGB2 is selected. In other case returns the ER401.

3.102. EDGE BLENDING [VXX:EDBI0]

Hexadecimal	02h	41h	44h	5Ah	5Ah	3Bh	56h	58h	58h	3Ah
Character		A	D	Z	Z	;	V	X	X	:
Hexadecimal	45h	44h	42h	49h	30h	3Dh	2Bh	*1	*3	*5
Character	E	D	B	I	0	=	+	*2	*4	*6
Hexadecimal	*7	*9	03h							
Character	*8	*10								

■ Parameters (*1,*2,*3,*4,*5,*6,*7,*8,*9,*10)

	OFF					ON					USER				
Hexadecimal	30h	30h	30h	30h	30h	30h	30h	30h	30h	31h	30h	30h	30h	30h	32h
Character	0	0	0	0	0	0	0	0	0	1	0	0	0	0	2

■ Response (Callback)

In the period when the command can be accepted

Hexadecimal	02h	56h	58h	58h	3Ah	45h	44h	42h	49h	30h
Character		V	X	X	:	E	D	B	I	0
Hexadecimal	3Dh	2Bh	*1	*3	*5	*7	*9	03h		
Character	=	+	*2	*4	*6	*8	*10			

Acceptability

SECURITY	STANDBY	ECO STANDBY	NO SIGNAL	SHUTTER	FREEZE	TEST PATTERN	REMOTE2	P IN P	LENS HOME
			✓	✓		✓	✓	✓	

3.103. EDGE BLENDING - UPPER ON/OFF [VGU]

Hexadecimal	02h	41h	44h	5Ah	5Ah	3Bh	56h	47h	55h	3Ah
Character		A	D	Z	Z	;	V	G	U	:
Hexadecimal	*1	03h								
Character	*2									

■ Parameters (*1,*2)

	OFF	ON
Hexadecimal	30h	31h
Character	0	1

■ Response (Callback)

In the period when the command can be accepted

Hexadecimal	02h	56h	47h	55h	3Ah	*1	03h
Character		V	G	U	:	*2	

Acceptability

SECURITY	STANDBY	ECO STANDBY	NO SIGNAL	SHUTTER	FREEZE	TEST PATTERN	REMOTE2	P IN P	LENS HOME
			✓	✓		✓	✓	✓	

3.104. EDGE BLENDING - LOWER ON/OFF [VGB]

Hexadecimal	02h	41h	44h	5Ah	5Ah	3Bh	56h	47h	42h	3Ah
Character		A	D	Z	Z	;	V	G	B	:
Hexadecimal	*1	03h								
Character	*2									

■ Parameters (*1,*2)

	OFF	ON
Hexadecimal	30h	31h
Character	0	1

■ Response (Callback)

In the period when the command can be accepted

Hexadecimal	02h	56h	47h	42h	3Ah	*1	03h
Character		V	G	B	:	*2	

Acceptability

SECURITY	STANDBY	ECO STANDBY	NO SIGNAL	SHUTTER	FREEZE	TEST PATTERN	REMOTE2	P IN P	LENS HOME
			✓	✓		✓	✓	✓	

3.105. EDGE BLENDING - LEFT ON/OFF [VGL]

Hexadecimal	02h	41h	44h	5Ah	5Ah	3Bh	56h	47h	4Ch	3Ah
Character		A	D	Z	Z	;	V	G	L	:
Hexadecimal	*1	03h								
Character	*2									

■ Parameters (*1,*2)

	OFF	ON
Hexadecimal	30h	31h
Character	0	1

■ Response (Callback)

In the period when the command can be accepted

Hexadecimal	02h	56h	47h	4Ch	3Ah	*1	03h
Character		V	G	L	:	*2	

Acceptability

SECURITY	STANDBY	ECO STANDBY	NO SIGNAL	SHUTTER	FREEZE	TEST PATTERN	REMOTE2	P IN P	LENS HOME
			✓	✓		✓	✓	✓	

3.106. EDGE BLENDING - RIGHT ON/OFF [VGR]

Hexadecimal	02h	41h	44h	5Ah	5Ah	3Bh	56h	47h	52h	3Ah
Character		A	D	Z	Z	;	V	G	R	:
Hexadecimal	*1	03h								
Character	*2									

■ Parameters (*1,*2)

	OFF	ON
Hexadecimal	30h	31h
Character	0	1

■ Response (Callback)

In the period when the command can be accepted

Hexadecimal	02h	56h	47h	52h	3Ah	*1	03h
Character		V	G	R	:	*2	

Acceptability

SECURITY	STANDBY	ECO STANDBY	NO SIGNAL	SHUTTER	FREEZE	TEST PATTERN	REMOTE2	P IN P	LENS HOME
			✓	✓		✓	✓	✓	

3.107. EDGE BLENDING - START - UPPER [VEU]

Hexadecimal	02h	41h	44h	5Ah	5Ah	3Bh	56h	45h	55h	3Ah
Character		A	D	Z	Z	;	V	E	U	:
Hexadecimal	*1	*3	*5	*7	03h					
Character	*2	*4	*6	*8						

■ Parameters (*1,*2,*3,*4,*5,*6,*7,*8)

	0				1199			
Hexadecimal	30h	30h	30h	30h	31h	31h	39h	39h
Character	0	0	0	0	1	1	9	9

■ Response (Callback)

In the period when the command can be accepted

Hexadecimal	02h	56h	45h	55h	3Ah	*1	*3	*5	*7	03h
Character		V	E	U	:	*2	*4	*6	*8	

Acceptability

SECURITY	STANDBY	ECO STANDBY	NO SIGNAL	SHUTTER	FREEZE	TEST PATTERN	REMOTE2	P IN P	LENS HOME
			✓	✓		✓	✓	✓	

■ Note:

- Maximum value will change by input signal or input resolution, width setting conditions.
- The minimum value is 0, and the maximum value be specified in a range of vertical resolution -1.

3.108. EDGE BLENDING - START - LOWER [VEB]

Hexadecimal	02h	41h	44h	5Ah	5Ah	3Bh	56h	45h	42h	3Ah
Character		A	D	Z	Z	;	V	E	B	:
Hexadecimal	*1	*3	*5	*7	03h					
Character	*2	*4	*6	*8						

■ Parameters (*1,*2,*3,*4,*5,*6,*7,*8)

	0				1199			
Hexadecimal	30h	30h	30h	30h	31h	31h	39h	39h
Character	0	0	0	0	1	1	9	9

■ Response (Callback)

In the period when the command can be accepted

Hexadecimal	02h	56h	45h	42h	3Ah	*1	*3	*5	*7	03h
Character		V	E	B	:	*2	*4	*6	*8	

Acceptability

SECURITY	STANDBY	ECO STANDBY	NO SIGNAL	SHUTTER	FREEZE	TEST PATTERN	REMOTE2	P IN P	LENS HOME
			✓	✓		✓	✓	✓	

■ Note:

- Maximum value will change by input signal or input resolution, width setting conditions.
- The minimum value is 0, and the maximum value be specified in a range of vertical resolution -1.

3.109. EDGE BLENDING - START - LEFT [VEL]

Hexadecimal	02h	41h	44h	5Ah	5Ah	3Bh	56h	45h	4Ch	3Ah
Character		A	D	Z	Z	;	V	E	L	:
Hexadecimal	*1	*3	*5	*7	03h					
Character	*2	*4	*6	*8						

■ Parameters (*1,*2,*3,*4,*5,*6,*7,*8)

	0				1919			
Hexadecimal	30h	30h	30h	30h	31h	39h	31h	39h
Character	0	0	0	0	1	9	1	9

■ Response (Callback)

In the period when the command can be accepted

Hexadecimal	02h	56h	45h	4Ch	3Ah	*1	*3	*5	*7	03h
Character		V	E	L	:	*2	*4	*6	*8	

Acceptability

SECURITY	STANDBY	ECO STANDBY	NO SIGNAL	SHUTTER	FREEZE	TEST PATTERN	REMOTE2	P IN P	LENS HOME
			✓	✓		✓	✓	✓	

■ Note:

- Maximum value will change by input signal or input resolution, width setting conditions.
- The minimum value is 0, and the maximum value be specified in a range of horizontal resolution -1.

3.110. EDGE BLENDING - START - RIGHT [VER]

Hexadecimal	02h	41h	44h	5Ah	5Ah	3Bh	56h	45h	52h	3Ah
Character		A	D	Z	Z	;	V	E	R	:
Hexadecimal	*1	*3	*5	*7	03h					
Character	*2	*4	*6	*8						

■ Parameters (*1,*2,*3,*4,*5,*6,*7,*8)

	0				1919			
Hexadecimal	30h	30h	30h	30h	31h	39h	31h	39h
Character	0	0	0	0	1	9	1	9

■ Response (Callback)

In the period when the command can be accepted

Hexadecimal	02h	56h	45h	52h	3Ah	*1	*3	*5	*7	03h
Character		V	E	R	:	*2	*4	*6	*8	

Acceptability

SECURITY	STANDBY	ECO STANDBY	NO SIGNAL	SHUTTER	FREEZE	TEST PATTERN	REMOTE2	P IN P	LENS HOME
			✓	✓		✓	✓	✓	

■ Note:

- Maximum value will change by input signal or input resolution, width setting conditions.
- The minimum value is 0, and the maximum value be specified in a range of horizontal resolution -1..

3.111. EDGE BLENDING - WIDTH - UPPER [VXX:EUIW0]

Hexadecimal	02h	41h	44h	5Ah	5Ah	3Bh	56h	58h	58h	3Ah
Character		A	D	Z	Z	;	V	X	X	:
Hexadecimal	45h	55h	57h	49h	30h	3Dh	2Bh	*1	*3	*5
Character	E	U	W	l	0	=	+	*2	*4	*6
Hexadecimal	*7	*9	03h							
Character	*8	*10								

■ Parameters (*1,*2,*3,*4,*5,*6,*7,*8,*9,*10)

	0					1199				
Hexadecimal	30h	30h	30h	30h	30h	30h	31h	31h	39h	39h
Character	0	0	0	0	0	0	1	1	9	9

■ Response (Callback)

In the period when the command can be accepted

Hexadecimal	02h	56h	58h	58h	3Ah	45h	55h	57h	49h	30h
Character		V	X	X	:	E	U	W	l	0
Hexadecimal	3Dh	2Bh	*1	*3	*5	*7	*9	03h		
Character	=	+	*2	*4	*6	*8	*10			

Acceptability

SECURITY	STANDBY	ECO STANDBY	NO SIGNAL	SHUTTER	FREEZE	TEST PATTERN	REMOTE2	P IN P	LENS HOME
			✓	✓		✓	✓	✓	

■ Note:

- Maximum value will change by input signal or input resolution or starting position setting conditions.
- The minimum value is 0, and the maximum value be specified in a range of vertical resolution -1..

3.112. EDGE BLENDING - WIDTH - LOWER [VXX:EBWI0]

Hexadecimal	02h	41h	44h	5Ah	5Ah	3Bh	56h	58h	58h	3Ah
Character		A	D	Z	Z	;	V	X	X	:
Hexadecimal	45h	42h	57h	49h	30h	3Dh	2Bh	*1	*3	*5
Character	E	B	W	l	0	=	+	*2	*4	*6
Hexadecimal	*7	*9	03h							
Character	*8	*10								

■ Parameters (*1,*2,*3,*4,*5,*6,*7,*8,*9,*10)

	0					1199				
Hexadecimal	30h	30h	30h	30h	30h	30h	31h	31h	39h	39h
Character	0	0	0	0	0	0	1	1	9	9

■ Response (Callback)

In the period when the command can be accepted

Hexadecimal	02h	56h	58h	58h	3Ah	45h	42h	57h	49h	30h
Character		V	X	X	:	E	B	W	l	0
Hexadecimal	3Dh	2Bh	*1	*3	*5	*7	*9	03h		
Character	=	+	*2	*4	*6	*8	*10			

Acceptability

SECURITY	STANDBY	ECO STANDBY	NO SIGNAL	SHUTTER	FREEZE	TEST PATTERN	REMOTE2	P IN P	LENS HOME
			✓	✓		✓	✓	✓	

■ Note:

- Maximum value will change by input signal or input resolution or starting position setting conditions.
- The minimum value is 0, and the maximum value be specified in a range of vertical resolution -1..

3.113. EDGE BLENDING - WIDTH - LEFT [VXX:ELWI0]

Hexadecimal	02h	41h	44h	5Ah	5Ah	3Bh	56h	58h	58h	3Ah
Character		A	D	Z	Z	;	V	X	X	:
Hexadecimal	45h	4Ch	57h	49h	30h	3Dh	2Bh	*1	*3	*5
Character	E	L	W	l	0	=	+	*2	*4	*6
Hexadecimal	*7	*9	03h							
Character	*8	*10								

■ Parameters (*1,*2,*3,*4,*5,*6,*7,*8,*9,*10)

	0					1919				
Hexadecimal	30h	30h	30h	30h	30h	30h	31h	39h	31h	39h
Character	0	0	0	0	0	0	1	9	1	9

■ Response (Callback)

In the period when the command can be accepted

Hexadecimal	02h	56h	58h	58h	3Ah	45h	4Ch	57h	49h	30h
Character		V	X	X	:	E	L	W	l	0
Hexadecimal	3Dh	2Bh	*1	*3	*5	*7	*9	03h		
Character	=	+	*2	*4	*6	*8	*10			

Acceptability

SECURITY	STANDBY	ECO STANDBY	NO SIGNAL	SHUTTER	FREEZE	TEST PATTERN	REMOTE2	P IN P	LENS HOME
			✓	✓		✓	✓	✓	

■ Note:

- Maximum value will change by input signal or input resolution or starting position setting conditions.
- The minimum value is 0, and the maximum value be specified in a range of vertical resolution -1.

3.114. EDGE BLENDING - WIDTH - RIGHT [VXX:ERWI0]

Hexadecimal	02h	41h	44h	5Ah	5Ah	3Bh	56h	58h	58h	3Ah
Character		A	D	Z	Z	;	V	X	X	:
Hexadecimal	45h	52h	57h	49h	30h	3Dh	2Bh	*1	*3	*5
Character	E	R	W	l	0	=	+	*2	*4	*6
Hexadecimal	*7	*9	03h							
Character	*8	*10								

■ Parameters (*1,*2,*3,*4,*5,*6,*7,*8,*9,*10)

	0					1919				
Hexadecimal	30h	30h	30h	30h	30h	30h	31h	39h	31h	39h
Character	0	0	0	0	0	0	1	9	1	9

■ Response (Callback)

In the period when the command can be accepted

Hexadecimal	02h	56h	58h	58h	3Ah	45h	52h	57h	49h	30h
Character		V	X	X	:	E	R	W	l	0
Hexadecimal	3Dh	2Bh	*1	*3	*5	*7	*9	03h		
Character	=	+	*2	*4	*6	*8	*10			

Acceptability

SECURITY	STANDBY	ECO STANDBY	NO SIGNAL	SHUTTER	FREEZE	TEST PATTERN	REMOTE2	P IN P	LENS HOME
			✓	✓		✓	✓	✓	

■ Note:

- Maximum value will change by input signal or input resolution or starting position setting conditions.
- The minimum value is 0, and the maximum value be specified in a range of vertical resolution -1.

3.115. EDGE BLENDING - MARKER ON/OFF [VGM]

Hexadecimal	02h	41h	44h	5Ah	5Ah	3Bh	56h	47h	4Dh	3Ah
Character		A	D	Z	Z	;	V	G	M	:
Hexadecimal	*1	03h								
Character	*2									

■ Parameters (*1,*2)

	OFF		ON	
Hexadecimal	30h		31h	
Character	0		1	

■ Response (Callback)

In the period when the command can be accepted

Hexadecimal	02h	56h	47h	4Dh	3Ah	*1	03h
Character		V	G	M	:	*2	

Acceptability

SECURITY	STANDBY	ECO STANDBY	NO SIGNAL	SHUTTER	FREEZE	TEST PATTERN	REMOTE2	P IN P	LENS HOME
			✓	✓		✓	✓	✓	

3.116. EDGE BLENDING - NON-OVERLAPPED BLACK LEVEL [VJI]

Hexadecimal	02h	41h	44h	5Ah	5Ah	3Bh	56h	4Ah	49h	3Ah
Character		A	D	Z	Z	;	V	J	I	:
Hexadecimal	*1	*3	*5	2Ch	*7	*9	*11	2Ch	*13	*15
Character	*2	*4	*6	,	*8	*10	*12	,	*14	*16
Hexadecimal	*17	2Ch	*19	*21	*23	03h				
Character	*18	,	*20	*22	*24					

■ Parameters (*1,*2,*3,*4,*5,*6): White

	0			255		
Hexadecimal	30h	30h	30h	32h	35h	35h
Character	0	0	0	2	5	5

Parameters (*7,*8,*9,*10,*11,*12): Red

	0			255		
Hexadecimal	30h	30h	30h	32h	35h	35h
Character	0	0	0	2	5	5

Parameters (*13,*14,*15,*16,*17,*18): Green

	0			255		
Hexadecimal	30h	30h	30h	32h	35h	35h
Character	0	0	0	2	5	5

Parameters (*19,*20,*21,*22,*23,*24): Blue

	0			255		
Hexadecimal	30h	30h	30h	32h	35h	35h
Character	0	0	0	2	5	5

■ Response (Callback)

In the period when the command can be accepted

Hexadecimal	02h	56h	4Ah	49h	3Ah	*1	*3	*5
Character		V	J	I	:	*2	*4	*6
Hexadecimal	2Ch	*7	*9	*11	2Ch	*13	*15	*17
Character	,	*8	*10	*12	,	*14	*16	*18
Hexadecimal	2Ch	*19	*21	*23				
Character	,	*20	*22	*24				

Acceptability

SECURITY	STANDBY	ECO STANDBY	NO SIGNAL	SHUTTER	FREEZE	TEST PATTERN	REMOTE2	P IN P	LENS HOME
			✓	✓		✓	✓	✓	

3.117. EDGE BLENDING - NON-OVERLAPPED BLACK LEVEL - INTERLOCKED [VXX:EBII1]

Hexadecimal	02h	41h	44h	5Ah	5Ah	3Bh	56h	58h	58h	3Ah
Character		A	D	Z	Z	;	V	X	X	:
Hexadecimal	45h	42h	49h	49h	31h	3Dh	2Bh	*1	*3	*5
Character	E	B	I	I	1	=	+	*2	*4	*6
Hexadecimal	*7	*9	03h							
Character	*8	*10								

■ Parameters (*1,*2,*3,*4,*5,*6,*7,*8,*9,*10)

	OFF					ON				
Hexadecimal	30h	30h	30h	30h	30h	30h	30h	30h	30h	31h
Character	0	0	0	0	0	0	0	0	0	1

■ Response (Callback)

In the period when the command can be accepted

Hexadecimal	02h	56h	58h	58h	3Ah	45h	42h	49h	49h	31h
Character		V	X	X	:	E	B	I	I	1
Hexadecimal	3Dh	2Bh	*1	*3	*5	*7	*9	03h		
Character	=	+	*2	*4	*6	*8	*10			

Acceptability

SECURITY	STANDBY	ECO STANDBY	NO SIGNAL	SHUTTER	FREEZE	TEST PATTERN	REMOTE2	P IN P	LENS HOME
			✓	✓		✓	✓	✓	

3.118. EDGE BLENDING - BLACK BORDER LEVEL [VJO]

Hexadecimal	02h	41h	44h	5Ah	5Ah	3Bh	56h	4Ah	4Fh	3Ah
Character		A	D	Z	Z	;	V	J	O	:
Hexadecimal	*1	*3	*5	2Ch	*7	*9	*11	2Ch	*13	*15
Character	*2	*4	*6	,	*8	*10	*12	,	*14	*16
Hexadecimal	*17	2Ch	*19	*21	*23	03h				
Character	*18	,	*20	*22	*24					

■ Parameters (*1,*2,*3,*4,*5,*6): White

	0			255		
Hexadecimal	30h	30h	30h	32h	35h	35h
Character	0	0	0	2	5	5

Parameters (*7,*8,*9,*10,*11,*12): Red

	0			255		
Hexadecimal	30h	30h	30h	32h	35h	35h
Character	0	0	0	2	5	5

Parameters (*13,*14,*15,*16,*17,*18): Green

	0			255		
Hexadecimal	30h	30h	30h	32h	35h	35h
Character	0	0	0	2	5	5

Parameters (*19,*20,*21,*22,*23,*24): Blue

	0			255		
Hexadecimal	30h	30h	30h	32h	35h	35h
Character	0	0	0	2	5	5

■ Response (Callback)

In the period when the command can be accepted

Hexadecimal	02h	56h	4Ah	4Fh	3Ah	*1	*3	*5
Character		V	J	O	:	*2	*4	*6
Hexadecimal	2Ch	*7	*9	*11	2Ch	*13	*15	*17
Character	,	*8	*10	*12	,	*14	*16	*18
Hexadecimal	2Ch	*19	*21	*23				
Character	,	*20	*22	*24				

Acceptability

SECURITY	STANDBY	ECO STANDBY	NO SIGNAL	SHUTTER	FREEZE	TEST PATTERN	REMOTE2	P IN P	LENS HOME
			✓	✓		✓	✓	✓	

3.119. EDGE BLENDING - BLACK BORDER LEVEL - INTERLOCKED [VXX:EBII2]

Hexadecimal	02h	41h	44h	5Ah	5Ah	3Bh	56h	58h	58h	3Ah
Character		A	D	Z	Z	;	V	X	X	:
Hexadecimal	45h	42h	49h	49h	32h	3Dh	2Bh	*1	*3	*5
Character	E	B	l	l	2	=	+	*2	*4	*6
Hexadecimal	*7	*9	03h							
Character	*8	*10								

■ Parameters (*1,*2,*3,*4,*5,*6,*7,*8,*9,*10)

	OFF					ON				
Hexadecimal	30h	30h	30h	30h	30h	30h	30h	30h	30h	31h
Character	0	0	0	0	0	0	0	0	0	1

■ Response (Callback)

In the period when the command can be accepted

Hexadecimal	02h	56h	58h	58h	3Ah	45h	42h	49h	49h	32h
Character		V	X	X	:	E	B	l	l	2
Hexadecimal	3Dh	2Bh	*1	*3	*5	*7	*9	03h		
Character	=	+	*2	*4	*6	*8	*10			

Acceptability

SECURITY	STANDBY	ECO STANDBY	NO SIGNAL	SHUTTER	FREEZE	TEST PATTERN	REMOTE2	P IN P	LENS HOME
			✓	✓		✓	✓	✓	

3.120. EDGE BLENDING - BLACK BORDER WIDTH - UPPER [VJU]

Hexadecimal	02h	41h	44h	5Ah	5Ah	3Bh	56h	4Ah	55h	3Ah
Character		A	D	Z	Z	;	V	J	U	:
Hexadecimal	*1	*3	*5	*7	03h					
Character	*2	*4	*6	*8						

■ Parameters (*1,*2,*3,*4,*5,*6,*7,*8)

	0				1199			
Hexadecimal	30h	30h	30h	30h	31h	31h	39h	39h
Character	0	0	0	0	1	1	9	9

■ Response (Callback)

In the period when the command can be accepted

Hexadecimal	02h	56h	4Ah	55h	3Ah	*1	*3	*5	*7	03h
Character		V	J	U	:	*2	*4	*6	*8	

Acceptability

SECURITY	STANDBY	ECO STANDBY	NO SIGNAL	SHUTTER	FREEZE	TEST PATTERN	REMOTE2	P IN P	LENS HOME
			✓	✓		✓	✓	✓	

■ Note:

- The maximum setting value will change by other setting conditions.
- The minimum value is 0, and the maximum value be specified in a range of vertical resolution -1.

3.121. EDGE BLENDING - BLACK BORDER WIDTH - LOWER [VJB]

Hexadecimal	02h	41h	44h	5Ah	5Ah	3Bh	56h	4Ah	42h	3Ah
Character		A	D	Z	Z	;	V	J	B	:
Hexadecimal	*1	*3	*5	*7	03h					
Character	*2	*4	*6	*8						

■ Parameters (*1,*2,*3,*4,*5,*6,*7,*8)

	0				1199			
Hexadecimal	30h	30h	30h	30h	31h	31h	39h	39h
Character	0	0	0	0	1	1	9	9

■ Response (Callback)

In the period when the command can be accepted

Hexadecimal	02h	56h	4Ah	42h	3Ah	*1	*3	*5	*7	03h
Character		V	J	B	:	*2	*4	*6	*8	

Acceptability

SECURITY	STANDBY	ECO STANDBY	NO SIGNAL	SHUTTER	FREEZE	TEST PATTERN	REMOTE2	P IN P	LENS HOME
			✓	✓		✓	✓	✓	

■ Note:

- The maximum setting value will change by other setting conditions..
- The minimum value is 0, and the maximum value be specified in a range of vertical resolution -1.

3.122. EDGE BLENDING - BLACK BORDER WIDTH - LEFT [VJL]

Hexadecimal	02h	41h	44h	5Ah	5Ah	3Bh	56h	4Ah	4Ch	3Ah
Character		A	D	Z	Z	;	V	J	L	:
Hexadecimal	*1	*3	*5	*7	03h					
Character	*2	*4	*6	*8						

■ Parameters (*1,*2,*3,*4,*5,*6,*7,*8)

	0				1919			
Hexadecimal	30h	30h	30h	30h	31h	39h	31h	39h
Character	0	0	0	0	1	9	1	9

■ Response (Callback)

In the period when the command can be accepted

Hexadecimal	02h	56h	4Ah	4Ch	3Ah	*1	*3	*5	*7	03h
Character		V	J	L	:	*2	*4	*6	*8	

Acceptability

SECURITY	STANDBY	ECO STANDBY	NO SIGNAL	SHUTTER	FREEZE	TEST PATTERN	REMOTE2	P IN P	LENS HOME
			✓	✓		✓	✓	✓	

■ Note:

- The maximum setting value will change by other setting conditions..
- The minimum value is 0, and the maximum value be specified in a range of horizontal resolution -1.

3.123. EDGE BLENDING - BLACK BORDER WIDTH - RIGHT [VJR]

Hexadecimal	02h	41h	44h	5Ah	5Ah	3Bh	56h	4Ah	52h	3Ah
Character		A	D	Z	Z	;	V	J	R	:
Hexadecimal	*1	*3	*5	*7	03h					
Character	*2	*4	*6	*8						

■ Parameters (*1,*2,*3,*4,*5,*6,*7,*8)

	0				1919			
Hexadecimal	30h	30h	30h	30h	31h	39h	31h	39h
Character	0	0	0	0	1	9	1	9

■ Response (Callback)

In the period when the command can be accepted

Hexadecimal	02h	56h	4Ah	52h	3Ah	*1	*3	*5	*7	03h
Character		V	J	R	:	*2	*4	*6	*8	

Acceptability

SECURITY	STANDBY	ECO STANDBY	NO SIGNAL	SHUTTER	FREEZE	TEST PATTERN	REMOTE2	P IN P	LENS HOME
			✓	✓		✓	✓	✓	

■ Note:

- The maximum setting value will change by other setting conditions..
- The minimum value is 0, and the maximum value be specified in a range of horizontal resolution -1..

3.124. EDGE BLENDING - BLACK BORDER WIDTH - UPPER KEYSTONE AREA [VXX:EBBI4]

Hexadecimal	02h	41h	44h	5Ah	5Ah	3Bh	56h	58h	58h	3Ah
Character		A	D	Z	Z	;	V	X	X	:
Hexadecimal	45h	42h	42h	49h	34h	3Dh	*1	*3	*5	*7
Character	E	B	B	l	4	=	*2	*4	*6	*8
Hexadecimal	*9	*11	03h							
Character	*10	*12								

■ Parameters (*1,*2,*3,*4,*5,*6,*7,*8,*9,*10,*11,*12)

	-1199						+1199					
Hexadecimal	2Dh	30h	31h	31h	39h	39h	2Bh	30h	31h	31h	39h	39h
Character	-	0	1	1	9	9	+	0	1	1	9	9

■ Response (Callback)

In the period when the command can be accepted

Hexadecimal	02h	56h	58h	58h	3Ah	45h	42h	42h	49h	34h
Character		V	X	X	:	E	B	B	l	4
Hexadecimal	3Dh	*1	*3	*5	*7	*9	*11	03h		
Character	=	*2	*4	*6	*8	*10	*12			

Acceptability

SECURITY	STANDBY	ECO STANDBY	NO SIGNAL	SHUTTER	FREEZE	TEST PATTERN	REMOTE2	P IN P	LENS HOME
			✓	✓		✓	✓	✓	

■ Note:

- The maximum setting value will change by BLACK BORDER WIDTH setting conditions.
- The minimum value is (BLACK BORDER WIDTH UPPER) -1, and maximum value is (BLACK BORDER WIDTH UPPER)+1.

3.125. EDGE BLENDING - BLACK BORDER WIDTH - LOWER KEYSTONE AREA [VXX:EBBI5]

Hexadecimal	02h	41h	44h	5Ah	5Ah	3Bh	56h	58h	58h	3Ah
Character		A	D	Z	Z	;	V	X	X	:
Hexadecimal	45h	42h	42h	49h	35h	3Dh	*1	*3	*5	*7
Character	E	B	B	l	5	=	*2	*4	*6	*8
Hexadecimal	*9	*11	03h							
Character	*10	*12								

■ Parameters (*1,*2,*3,*4,*5,*6,*7,*8,*9,*10,*11,*12)

	-1199						+1199					
Hexadecimal	2Dh	30h	31h	31h	39h	39h	2Bh	30h	31h	31h	39h	39h
Character	-	0	1	1	9	9	+	0	1	1	9	9

■ Response (Callback)

In the period when the command can be accepted

Hexadecimal	02h	56h	58h	58h	3Ah	45h	42h	42h	49h	35h
Character		V	X	X	:	E	B	B	l	5
Hexadecimal	3Dh	*1	*3	*5	*7	*9	*11	03h		
Character	=	*2	*4	*6	*8	*10	*12			

Acceptability

SECURITY	STANDBY	ECO STANDBY	NO SIGNAL	SHUTTER	FREEZE	TEST PATTERN	REMOTE2	P IN P	LENS HOME
			✓	✓		✓	✓	✓	

■ Note:

- The maximum setting value will change by BLACK BORDER WIDTH setting conditions..
- The minimum value is (BLACK BORDER WIDTH LOWER) -1, and maximum value is (BLACK BORDER WIDTH LOWER)+1.

3.126. EDGE BLENDING - BLACK BORDER WIDTH - LEFT KEYSTONE AREA [VXX:EBBI6]

Hexadecimal	02h	41h	44h	5Ah	5Ah	3Bh	56h	58h	58h	3Ah
Character		A	D	Z	Z	;	V	X	X	:
Hexadecimal	45h	42h	42h	49h	36h	3Dh	*1	*3	*5	*7
Character	E	B	B	l	6	=	*2	*4	*6	*8
Hexadecimal	*9	*11	03h							
Character	*10	*12								

■ Parameters (*1,*2,*3,*4,*5,*6,*7,*8,*9,*10,*11,*12)

	-1919						+1919					
Hexadecimal	2Dh	30h	31h	39h	31h	39h	2Bh	30h	30h	30h	30h	31h
Character	-	0	1	9	1	9	+	0	1	9	1	9

■ Response (Callback)

In the period when the command can be accepted

Hexadecimal	02h	56h	58h	58h	3Ah	45h	42h	42h	49h	36h
Character		V	X	X	:	E	B	B	l	6
Hexadecimal	3Dh	*1	*3	*5	*7	*9	*11	03h		
Character	=	*2	*4	*6	*8	*10	*12			

Acceptability

SECURITY	STANDBY	ECO STANDBY	NO SIGNAL	SHUTTER	FREEZE	TEST PATTERN	REMOTE2	P IN P	LENS HOME
			✓	✓		✓	✓	✓	

■ Note:

- The maximum setting value will change by BLACK BORDER WIDTH setting conditions..
- The minimum value is (BLACK BORDER WIDTH LEFT) -1, and maximum value is (BLACK BORDER WIDTH LEFT) +1.

3.127. EDGE BLENDING - BLACK BORDER WIDTH - RIGHT KEystone AREA [VXX:EBBI7]

Hexadecimal	02h	41h	44h	5Ah	5Ah	3Bh	56h	58h	58h	3Ah
Character		A	D	Z	Z	;	V	X	X	:
Hexadecimal	45h	42h	42h	49h	37h	3Dh	*1	*3	*5	*7
Character	E	B	B	l	7	=	*2	*4	*6	*8
Hexadecimal	*9	*11	03h							
Character	*10	*12								

■ Parameters (*1,*2,*3,*4,*5,*6,*7,*8,*9,*10,*11,*12)

	-1919						+1919					
Hexadecimal	2Dh	30h	31h	39h	31h	39h	2Bh	30h	31h	39h	31h	39h
Character	-	0	1	9	1	9	+	0	1	9	1	9

■ Response (Callback)

In the period when the command can be accepted

Hexadecimal	02h	56h	58h	58h	3Ah	45h	42h	42h	49h	37h
Character		V	X	X	:	E	B	B	l	7
Hexadecimal	3Dh	*1	*3	*5	*7	*9	*11	03h		
Character	=	*2	*4	*6	*8	*10	*12			

Acceptability

SECURITY	STANDBY	ECO STANDBY	NO SIGNAL	SHUTTER	FREEZE	TEST PATTERN	REMOTE2	P IN P	LENS HOME
			✓	✓		✓	✓	✓	

■ Note:

- The maximum setting value will change by BLACK BORDER WIDTH setting conditions..
- The minimum value is (BLACK BORDER WIDTH RIGHT) -1, and maximum value is (BLACK BORDER WIDTH RIGHT) +1.

3.128. EDGE BLENDING - OVERLAPPED BLACK LEVEL - UPPER [VXX:EBBS0]

Hexadecimal	02h	41h	44h	5Ah	5Ah	3Bh	56h	58h	58h	3Ah
Character		A	D	Z	Z	;	V	X	X	:
Hexadecimal	45h	42h	42h	53h	30h	3Dh	*1	*3	*5	2Ch
Character	E	B	B	S	0	=	*2	*4	*6	,
Hexadecimal	*7	*9	*11	2Ch	*13	*15	*17	2Ch	*19	*21
Character	*8	*10	*12	,	*14	*16	*18	,	*20	*22
Hexadecimal	*23	03h								
Character	*24									

■ Parameters (*1,*2,*3,*4,*5,*6): White

	0			255		
Hexadecimal	30h	30h	30h	32h	35h	35h
Character	0	0	0	2	5	5

Parameters (*7,*8,*9,*10,*11,*12): Red

	0			255		
Hexadecimal	30h	30h	30h	32h	35h	35h
Character	0	0	0	2	5	5

Parameters (*13,*14,*15,*16,*17,*18): Green

	0			255		
Hexadecimal	30h	30h	30h	32h	35h	35h
Character	0	0	0	2	5	5

Parameters (*19,*20,*21,*22,*23,*24): Blue

	0			255		
Hexadecimal	30h	30h	30h	32h	35h	35h
Character	0	0	0	2	5	5

■ Response (Callback)

In the period when the command can be accepted

Hexadecimal	02h	56h	58h	58h	3Ah	45h	42h	42h	53h	30h
Character		V	X	X	:	E	B	B	S	0
Hexadecimal	3Dh	*1	*3	*5	2Ch	*7	*9	*11	2Ch	*13
Character	=	*2	*4	*6	,	*8	*10	*12	,	*14
Hexadecimal	*15	*17	2Ch	*19	*21	*23	03h			
Character	*16	*18	,	*20	*22	*24				

Acceptability

SECURITY	STANDBY	ECO STANDBY	NO SIGNAL	SHUTTER	FREEZE	TEST PATTERN	REMOTE2	P IN P	LENS HOME
			✓	✓		✓	✓	✓	

3.129. EDGE BLENDING - OVERLAPPED BLACK LEVEL - LOWER [VXX:EBBS1]

Hexadecimal	02h	41h	44h	5Ah	5Ah	3Bh	56h	58h	58h	3Ah
Character		A	D	Z	Z	;	V	X	X	:
Hexadecimal	45h	42h	42h	53h	31h	3Dh	*1	*3	*5	2Ch
Character	E	B	B	S	1	=	*2	*4	*6	,
Hexadecimal	*7	*9	*11	2Ch	*13	*15	*17	2Ch	*19	*21
Character	*8	*10	*12	,	*14	*16	*18	,	*20	*22
Hexadecimal	*23	03h								
Character	*24									

■ Parameters (*1,*2,*3,*4,*5,*6): White

	0			255		
Hexadecimal	30h	30h	30h	32h	35h	35h
Character	0	0	0	2	5	5

Parameters (*7,*8,*9,*10,*11,*12): Red

	0			255		
Hexadecimal	30h	30h	30h	32h	35h	35h
Character	0	0	0	2	5	5

Parameters (*13,*14,*15,*16,*17,*18): Green

	0			255		
Hexadecimal	30h	30h	30h	32h	35h	35h
Character	0	0	0	2	5	5

Parameters (*19,*20,*21,*22,*23,*24): Blue

	0			255		
Hexadecimal	30h	30h	30h	32h	35h	35h
Character	0	0	0	2	5	5

■ Response (Callback)

In the period when the command can be accepted

Hexadecimal	02h	56h	58h	58h	3Ah	45h	42h	42h	53h	31h
Character		V	X	X	:	E	B	B	S	1
Hexadecimal	3Dh	*1	*3	*5	2Ch	*7	*9	*11	2Ch	*13
Character	=	*2	*4	*6	,	*8	*10	*12	,	*14
Hexadecimal	*15	*17	2Ch	*19	*21	*23	03h			
Character	*16	*18	,	*20	*22	*24				

Acceptability

SECURITY	STANDBY	ECO STANDBY	NO SIGNAL	SHUTTER	FREEZE	TEST PATTERN	REMOTE2	P IN P	LENS HOME
			✓	✓		✓	✓	✓	

3.130. EDGE BLENDING - OVERLAPPED BLACK LEVEL - LEFT [VXX:EBBS2]

Hexadecimal	02h	41h	44h	5Ah	5Ah	3Bh	56h	58h	58h	3Ah
Character		A	D	Z	Z	;	V	X	X	:
Hexadecimal	45h	42h	42h	53h	32h	3Dh	*1	*3	*5	2Ch
Character	E	B	B	S	2	=	*2	*4	*6	,
Hexadecimal	*7	*9	*11	2Ch	*13	*15	*17	2Ch	*19	*21
Character	*8	*10	*12	,	*14	*16	*18	,	*20	*22
Hexadecimal	*23	03h								
Character	*24									

■ Parameters (*1,*2,*3,*4,*5,*6): White

	0			255		
Hexadecimal	30h	30h	30h	32h	35h	35h
Character	0	0	0	2	5	5

Parameters (*7,*8,*9,*10,*11,*12): Red

	0			255		
Hexadecimal	30h	30h	30h	32h	35h	35h
Character	0	0	0	2	5	5

Parameters (*13,*14,*15,*16,*17,*18): Green

	0			255		
Hexadecimal	30h	30h	30h	32h	35h	35h
Character	0	0	0	2	5	5

Parameters (*19,*20,*21,*22,*23,*24): Blue

	0			255		
Hexadecimal	30h	30h	30h	32h	35h	35h
Character	0	0	0	2	5	5

■ Response (Callback)

In the period when the command can be accepted

Hexadecimal	02h	56h	58h	58h	3Ah	45h	42h	42h	53h	32h
Character		V	X	X	:	E	B	B	S	2
Hexadecimal	3Dh	*1	*3	*5	2Ch	*7	*9	*11	2Ch	*13
Character	=	*2	*4	*6	,	*8	*10	*12	,	*14
Hexadecimal	*15	*17	2Ch	*19	*21	*23	03h			
Character	*16	*18	,	*20	*22	*24				

Acceptability

SECURITY	STANDBY	ECO STANDBY	NO SIGNAL	SHUTTER	FREEZE	TEST PATTERN	REMOTE2	P IN P	LENS HOME
			✓	✓		✓	✓	✓	

3.131. EDGE BLENDING - OVERLAPPED BLACK LEVEL - RIGHT [VXX:EBBS3]

Hexadecimal	02h	41h	44h	5Ah	5Ah	3Bh	56h	58h	58h	3Ah
Character		A	D	Z	Z	;	V	X	X	:
Hexadecimal	45h	42h	42h	53h	33h	3Dh	*1	*3	*5	2Ch
Character	E	B	B	S	3	=	*2	*4	*6	,
Hexadecimal	*7	*9	*11	2Ch	*13	*15	*17	2Ch	*19	*21
Character	*8	*10	*12	,	*14	*16	*18	,	*20	*22
Hexadecimal	*23	03h								
Character	*24									

■ Parameters (*1,*2,*3,*4,*5,*6): White

	0			255		
Hexadecimal	30h	30h	30h	32h	35h	35h
Character	0	0	0	2	5	5

Parameters (*7,*8,*9,*10,*11,*12): Red

	0			255		
Hexadecimal	30h	30h	30h	32h	35h	35h
Character	0	0	0	2	5	5

Parameters (*13,*14,*15,*16,*17,*18): Green

	0			255		
Hexadecimal	30h	30h	30h	32h	35h	35h
Character	0	0	0	2	5	5

Parameters (*19,*20,*21,*22,*23,*24): Blue

	0			255		
Hexadecimal	30h	30h	30h	32h	35h	35h
Character	0	0	0	2	5	5

■ Response (Callback)

In the period when the command can be accepted

Hexadecimal	02h	56h	58h	58h	3Ah	45h	42h	42h	53h	33h
Character		V	X	X	:	E	B	B	S	3
Hexadecimal	3Dh	*1	*3	*5	2Ch	*7	*9	*11	2Ch	*13
Character	=	*2	*4	*6	,	*8	*10	*12	,	*14
Hexadecimal	*15	*17	2Ch	*19	*21	*23	03h			
Character	*16	*18	,	*20	*22	*24				

Acceptability

SECURITY	STANDBY	ECO STANDBY	NO SIGNAL	SHUTTER	FREEZE	TEST PATTERN	REMOTE2	P IN P	LENS HOME
			✓	✓		✓	✓	✓	

3.132. EDGE BLENDING - OVERLAPPED BLACK LEVEL - UPPER INTERLOCKED [VXX:EBII3]

Hexadecimal	02h	41h	44h	5Ah	5Ah	3Bh	56h	58h	58h	3Ah
Character		A	D	Z	Z	;	V	X	X	:
Hexadecimal	45h	42h	49h	49h	33h	3Dh	2Bh	*1	*3	*5
Character	E	B	I	I	3	=	+	*2	*4	*6
Hexadecimal	*7	*9	03h							
Character	*8	*10								

■ Parameters (*1,*2,*3,*4,*5,*6,*7,*8,*9,*10)

	OFF					ON				
Hexadecimal	30h	30h	30h	30h	30h	30h	30h	30h	30h	31h
Character	0	0	0	0	0	0	0	0	0	1

■ Response (Callback)

In the period when the command can be accepted

Hexadecimal	02h	56h	58h	58h	3Ah	45h	42h	49h	49h	33h
Character		V	X	X	:	E	B	I	I	3
Hexadecimal	3Dh	2Bh	*1	*3	*5	*7	*9	03h		
Character	=	+	*2	*4	*6	*8	*10			

Acceptability

SECURITY	STANDBY	ECO STANDBY	NO SIGNAL	SHUTTER	FREEZE	TEST PATTERN	REMOTE2	P IN P	LENS HOME
			✓	✓		✓	✓	✓	

3.133. EDGE BLENDING - OVERLAPPED BLACK LEVEL - LOWER INTERLOCKED [VXX:EBII4]

Hexadecimal	02h	41h	44h	5Ah	5Ah	3Bh	56h	58h	58h	3Ah
Character		A	D	Z	Z	;	V	X	X	:
Hexadecimal	45h	42h	49h	49h	34h	3Dh	2Bh	*1	*3	*5
Character	E	B	l	l	4	=	+	*2	*4	*6
Hexadecimal	*7	*9	03h							
Character	*8	*10								

■ Parameters (*1,*2,*3,*4,*5,*6,*7,*8,*9,*10)

	OFF					ON				
Hexadecimal	30h	30h	30h	30h	30h	30h	30h	30h	30h	31h
Character	0	0	0	0	0	0	0	0	0	1

■ Response (Callback)

In the period when the command can be accepted

Hexadecimal	02h	56h	58h	58h	3Ah	45h	42h	49h	49h	34h
Character		V	X	X	:	E	B	l	l	4
Hexadecimal	3Dh	2Bh	*1	*3	*5	*7	*9	03h		
Character	=	+	*2	*4	*6	*8	*10			

Acceptability

SECURITY	STANDBY	ECO STANDBY	NO SIGNAL	SHUTTER	FREEZE	TEST PATTERN	REMOTE2	P IN P	LENS HOME
			✓	✓		✓	✓	✓	

3.134. EDGE BLENDING - OVERLAPPED BLACK LEVEL - LEFT INTERLOCKED [VXX:EBII5]

Hexadecimal	02h	41h	44h	5Ah	5Ah	3Bh	56h	58h	58h	3Ah
Character		A	D	Z	Z	;	V	X	X	:
Hexadecimal	45h	42h	49h	49h	35h	3Dh	2Bh	*1	*3	*5
Character	E	B	l	l	5	=	+	*2	*4	*6
Hexadecimal	*7	*9	03h							
Character	*8	*10								

■ Parameters (*1,*2,*3,*4,*5,*6,*7,*8,*9,*10)

	OFF					ON				
Hexadecimal	30h	30h	30h	30h	30h	30h	30h	30h	30h	31h
Character	0	0	0	0	0	0	0	0	0	1

■ Response (Callback)

In the period when the command can be accepted

Hexadecimal	02h	56h	58h	58h	3Ah	45h	42h	49h	49h	35h
Character		V	X	X	:	E	B	l	l	5
Hexadecimal	3Dh	2Bh	*1	*3	*5	*7	*9	03h		
Character	=	+	*2	*4	*6	*8	*10			

Acceptability

SECURITY	STANDBY	ECO STANDBY	NO SIGNAL	SHUTTER	FREEZE	TEST PATTERN	REMOTE2	P IN P	LENS HOME
			✓	✓		✓	✓	✓	

3.135. EDGE BLENDING - OVERLAPPED BLACK LEVEL - RIGHT INTERLOCKED [VXX:EBII6]

Hexadecimal	02h	41h	44h	5Ah	5Ah	3Bh	56h	58h	58h	3Ah
Character		A	D	Z	Z	;	V	X	X	:
Hexadecimal	45h	42h	49h	49h	36h	3Dh	2Bh	*1	*3	*5
Character	E	B	l	l	6	=	+	*2	*4	*6
Hexadecimal	*7	*9	03h							
Character	*8	*10								

■ Parameters (*1,*2,*3,*4,*5,*6,*7,*8,*9,*10)

	OFF					ON				
Hexadecimal	30h	30h	30h	30h	30h	30h	30h	30h	30h	31h
Character	0	0	0	0	0	0	0	0	0	1

■ Response (Callback)

In the period when the command can be accepted

Hexadecimal	02h	56h	58h	58h	3Ah	45h	42h	49h	49h	36h
Character		V	X	X	:	E	B	l	l	6
Hexadecimal	3Dh	2Bh	*1	*3	*5	*7	*9	03h		
Character	=	+	*2	*4	*6	*8	*10			

Acceptability

SECURITY	STANDBY	ECO STANDBY	NO SIGNAL	SHUTTER	FREEZE	TEST PATTERN	REMOTE2	P IN P	LENS HOME
			✓	✓		✓	✓	✓	

3.136. FRAME RESPONSE [VXX:FDYI0]

Hexadecimal	02h	41h	44h	5Ah	5Ah	3Bh	56h	58h	58h	3Ah
Character		A	D	Z	Z	;	V	X	X	:
Hexadecimal	46h	44h	59h	49h	30h	3Dh	2Bh	*1	*3	*5
Character	F	D	Y	I	0	=	+	*2	*4	*6
Hexadecimal	*7	*9	03h							
Character	*8	*10								

■ Parameters (*1,*2,*3,*4,*5,*6,*7,*8,*9,*10)

	NORMAL					FAST					FIXED				
Hexadecimal	30h	30h	30h	30h	30h	30h	30h	30h	30h	31h	30h	30h	30h	30h	35h
Character	0	0	0	0	0	0	0	0	0	1	0	0	0	0	5

■ Response (Callback)

In the period when the command can be accepted

Hexadecimal	02h	56h	58h	58h	3Ah	46h	44h	59h	49h	30h
Character		V	X	X	:	F	D	Y	I	0
Hexadecimal	3Dh	2Bh	*1	*3	*5	*7	*9	03h		
Character	=	+	*2	*4	*6	*8	*10			

Acceptability

SECURITY	STANDBY	ECO STANDBY	NO SIGNAL	SHUTTER	FREEZE	TEST PATTERN	REMOTE2	P IN P	LENS HOME
				✓		✓	✓		

3.137. RASTER POSITION - HORIZONTAL [VRH]

Hexadecimal	02h	41h	44h	5Ah	5Ah	3Bh	56h	52h	48h	3Ah
Character		A	D	Z	Z	;	V	R	H	:
Hexadecimal	*1	*3	*5	*7	03h					
Character	*2	*4	*6	*8						

■ Parameters (*1,*2,*3,*4,*5,*6,*7,*8)

	-2048				-2047			
Hexadecimal	32h	39h	35h	32h	32h	39h	35h	33h
Character	2	9	5	2	2	9	5	3
	+2046				+2047			
Hexadecimal	37h	30h	34h	36h	37h	30h	34h	37h
Character	7	0	4	6	7	0	4	7

■ Response (Callback)

In the period when the command can be accepted

Hexadecimal	02h	56h	52h	48h	3Ah	*1	*3	*5	03h
Character		V	R	H	:	*2	*4	*6	

Acceptability

SECURITY	STANDBY	ECO STANDBY	NO SIGNAL	SHUTTER	FREEZE	TEST PATTERN	REMOTE2	P IN P	LENS HOME
				✓		✓	✓	✓	

■ Note:

· Maximum value will change by input signal or aspect, zoom setting conditions.

3.138. RASTER POSITION - VERTICAL [VRV]

Hexadecimal	02h	41h	44h	5Ah	5Ah	3Bh	56h	52h	56h	3Ah
Character		A	D	Z	Z	;	V	R	V	:
Hexadecimal	*1	*3	*5	*7	03h					
Character	*2	*4	*6	*8						

■ Parameters (*1,*2,*3,*4,*5,*6,*7,*8)

	-2048				-2047			
Hexadecimal	32h	39h	35h	32h	32h	39h	35h	33h
Character	2	9	5	2	2	9	5	3
	+2046				+2047			
Hexadecimal	37h	30h	34h	36h	37h	30h	34h	37h
Character	7	0	4	6	7	0	4	7

■ Response (Callback)

In the period when the command can be accepted

Hexadecimal	02h	56h	52h	56h	3Ah	*1	*3	*5	03h
Character		V	R	V	:	*2	*4	*6	

Acceptability

SECURITY	STANDBY	ECO STANDBY	NO SIGNAL	SHUTTER	FREEZE	TEST PATTERN	REMOTE2	P IN P	LENS HOME
				✓		✓	✓	✓	

■ Note:

· Maximum value will change by input signal or aspect, zoom setting conditions.

3.139. DISPLAY LANGUAGE [OLG]

Hexadecimal	02h	41h	44h	5Ah	5Ah	3Bh	4Fh	4Ch	47h	3Ah
Character		A	D	Z	Z	;	O	L	G	:
Hexadecimal	*1	*3	*5	03h						
Character	*2	*4	*6							

■ Parameters (*1,*2,*3,*4,*5,*6)

	English			German			France		
Hexadecimal	45h	4Eh	47h	44h	45h	55h	46h	52h	41h
Character	E	N	G	D	E	U	F	R	A
	Spanish			Italian			Portuguese		
Hexadecimal	45h	53h	50h	49h	54h	4Ch	50h	4Fh	52h
Character	E	S	P	I	T	L	P	O	R
	Japanese			Chinese			Russian		
Hexadecimal	4Ah	50h	4Eh	43h	48h	49h	52h	55h	53h
Character	J	P	N	C	H	I	R	U	S
	Korean								
Hexadecimal	4Bh	4Fh	52h						
Character	K	O	R						

■ Response (Callback)

In the period when the command can be accepted

Hexadecimal	02h	4Fh	4Ch	47h	3Ah	*1	*3	*5	03h
Character		O	L	G	:	*2	*4	*6	

Acceptability

SECURITY	STANDBY	ECO STANDBY	NO SIGNAL	SHUTTER	FREEZE	TEST PATTERN	REMOTE2	P IN P	LENS HOME
	✓		✓	✓		✓	✓	✓	

3.140. COLOR MATCHING [VXX:CMAI0]

Hexadecimal	02h	41h	44h	5Ah	5Ah	3Bh	56h	58h	58h	3Ah
Character		A	D	Z	Z	;	V	X	X	:
Hexadecimal	44h	4Dh	41h	49h	30h	3Dh	2Bh	*1	*3	*5
Character	C	M	A	I	0	=	+	*2	*4	*6
Hexadecimal	*7	*9	03h							
Character	*8	*10								

■ Parameters (*1,*2,*3,*4,*5,*6,*7,*8,*9,*10)

	OFF					3COLORS					7COLORS				
Hexadecimal	30h	30h	30h	30h	30h	30h	30h	30h	30h	31h	30h	30h	30h	30h	32h
30hCharacter	0	0	0	0	0	0	0	0	0	1	0	0	0	0	2
	MEASURED														
Hexadecimal	30h	30h	30h	30h	34h										
Character	0	0	0	0	4										

■ Response (Callback)

In the period when the command can be accepted

Hexadecimal	02h	56h	58h	58h	3Ah	44h	4Dh	41h	49h	30h
Character		V	X	X	:	C	M	A	I	0
Hexadecimal	3Dh	2Bh	*1	*3	*5	*7	*9	03h		
Character	=	+	*2	*4	*6	*8	*10			

Acceptability

SECURITY	STANDBY	ECO STANDBY	NO SIGNAL	SHUTTER	FREEZE	TEST PATTERN	REMOTE2	P IN P	LENS HOME
			✓	✓		✓	✓	✓	

3.141. COLOR CORRECTION [VCM]

Hexadecimal	02h	41h	44h	5Ah	5Ah	3Bh	56h	43h	4Dh	3Ah
Character		A	D	Z	Z	;	V	C	M	:
Hexadecimal	*1	03h								
Character	*2									

■ Parameters (*1,*2)

	OFF		USER	
Hexadecimal	30h		31h	
Character	0		1	

■ Response (Callback)

In the period when the command can be accepted

Hexadecimal	02h	56h	43h	4Dh	3Ah	*1	03h
Character		V	C	M	:	*2	

Acceptability

SECURITY	STANDBY	ECO STANDBY	NO SIGNAL	SHUTTER	FREEZE	TEST PATTERN	REMOTE2	P IN P	LENS HOME
			✓	✓		✓	✓	✓	

3.142. COLOR CORRECTION - RED [VXX:CCRI0]

Hexadecimal	02h	41h	44h	5Ah	5Ah	3Bh	56h	58h	58h	3Ah	43h	43h
Character		A	D	Z	Z	;	V	X	X	:	C	C
Hexadecimal	52	49h	30h	3Dh	*1	*3	*5	*7	*9	*11	03h	
Character	R	I	0	=	*2	*4	*6	*8	*10	*12		

■ Parameters (*1,*2,*3,*4,*5,*6,*7,*8,*9,*10,*11,*12)

	-30						-29					
Hexadecimal	2Dh	30h	30h	30h	33h	30h	2Dh	30h	30h	30h	32h	39h
Character	—	0	0	0	3	0	—	0	0	0	2	9
	29						30					
Hexadecimal	2Bh	30h	30h	30h	32h	39h	2Bh	30h	30h	30h	33h	30h
Character	+	0	0	0	2	9	+	0	0	0	3	0

■ Response (Callback)

In the period when the command can be accepted

Hexadecimal	02h	56h	58h	58h	3Ah	43h	43h	52h	49h	30h
Character		V	X	X	:	C	C	R	I	0
Hexadecimal	3Dh	*1	*3	*5	*7	*9	*11	03h		
Character	=	*2	*4	*6	*8	*10	*12			

Acceptability

SECURITY	STANDBY	ECO STANDBY	NO SIGNAL	SHUTTER	FREEZE	TEST PATTERN	REMOTE2	P IN P	LENS HOME
			✓	✓		✓	✓	✓	

3.143. COLOR CORRECTION - GREEN [VXX:CCRI1]

Hexadecimal	02h	41h	44h	5Ah	5Ah	3Bh	56h	58h	58h	3Ah	43h	43h
Character		A	D	Z	Z	;	V	X	X	:	C	C
Hexadecimal	52	49h	30h	3Dh	*1	*3	*5	*7	*9	*11	03h	
Character	R	I	1	=	*2	*4	*6	*8	*10	*12		

■ Parameters (*1,*2,*3,*4,*5,*6,*7,*8,*9,*10,*11,*12)

	-30						-29					
Hexadecimal	2Dh	30h	30h	30h	33h	30h	2Dh	30h	30h	30h	32h	39h
Character	—	0	0	0	3	0	—	0	0	0	2	9
	29						30					
Hexadecimal	2Bh	30h	30h	30h	32h	39h	2Bh	30h	30h	30h	33h	30h
Character	+	0	0	0	2	9	+	0	0	0	3	0

■ Response (Callback)

In the period when the command can be accepted

Hexadecimal	02h	56h	58h	58h	3Ah	43h	43h	52h	49h	31h
Character		V	X	X	:	C	C	R	I	1
Hexadecimal	3Dh	*1	*3	*5	*7	*9	*11	03h		
Character	=	*2	*4	*6	*8	*10	*12			

Acceptability

SECURITY	STANDBY	ECO STANDBY	NO SIGNAL	SHUTTER	FREEZE	TEST PATTERN	REMOTE2	P IN P	LENS HOME
			✓	✓		✓	✓	✓	

3.144. COLOR CORRECTION - BLUE [VXX:CCRI2]

Hexadecimal	02h	41h	44h	5Ah	5Ah	3Bh	56h	58h	58h	3Ah	43h	43h
Character		A	D	Z	Z	;	V	X	X	:	C	C
Hexadecimal	52	49h	32h	3Dh	*1	*3	*5	*7	*9	*11	03h	
Character	R	I	2	=	*2	*4	*6	*8	*10	*12		

■ Parameters (*1,*2,*3,*4,*5,*6,*7,*8,*9,*10,*11,*12)

	-30						-29					
Hexadecimal	2Dh	30h	30h	30h	33h	30h	2Dh	30h	30h	30h	32h	39h
Character	—	0	0	0	3	0	—	0	0	0	2	9
	29						30					
Hexadecimal	2Bh	30h	30h	30h	32h	39h	2Bh	30h	30h	30h	33h	30h
Character	+	0	0	0	2	9	+	0	0	0	3	0

■ Response (Callback)

In the period when the command can be accepted

Hexadecimal	02h	56h	58h	58h	3Ah	43h	43h	52h	49h	32h
Character		V	X	X	:	C	C	R	I	2
Hexadecimal	3Dh	*1	*3	*5	*7	*9	*11	03h		
Character	=	*2	*4	*6	*8	*10	*12			

Acceptability

SECURITY	STANDBY	ECO STANDBY	NO SIGNAL	SHUTTER	FREEZE	TEST PATTERN	REMOTE2	P IN P	LENS HOME
			✓	✓		✓	✓	✓	

3.145. COLOR CORRECTION - CYAN [VXX:CCRI3]

Hexadecimal	02h	41h	44h	5Ah	5Ah	3Bh	56h	58h	58h	3Ah	43h	43h
Character		A	D	Z	Z	:	V	X	X	:	C	C
Hexadecimal	52	49h	33h	3Dh	*1	*3	*5	*7	*9	*11	03h	
Character	R	I	3	=	*2	*4	*6	*8	*10	*12		

■ Parameters (*1,*2,*3,*4,*5,*6,*7,*8,*9,*10,*11,*12)

	-30						-29					
Hexadecimal	2Dh	30h	30h	30h	33h	30h	2Dh	30h	30h	30h	32h	39h
Character	—	0	0	0	3	0	—	0	0	0	2	9
	29						30					
Hexadecimal	2Bh	30h	30h	30h	32h	39h	2Bh	30h	30h	30h	33h	30h
Character	+	0	0	0	2	9	+	0	0	0	3	0

■ Response (Callback)

In the period when the command can be accepted

Hexadecimal	02h	56h	58h	58h	3Ah	43h	43h	52h	49h	33h
Character		V	X	X	:	C	C	R	I	3
Hexadecimal	3Dh	*1	*3	*5	*7	*9	*11	03h		
Character	=	*2	*4	*6	*8	*10	*12			

Acceptability

SECURITY	STANDBY	ECO STANDBY	NO SIGNAL	SHUTTER	FREEZE	TEST PATTERN	REMOTE2	P IN P	LENS HOME
			✓	✓		✓	✓	✓	

3.146. COLOR CORRECTION - MAGENTA [VXX:CCRI4]

Hexadecimal	02h	41h	44h	5Ah	5Ah	3Bh	56h	58h	58h	3Ah	43h	43h
Character		A	D	Z	Z	:	V	X	X	:	C	C
Hexadecimal	52	49h	34h	3Dh	*1	*3	*5	*7	*9	*11	03h	
Character	R	I	4	=	*2	*4	*6	*8	*10	*12		

■ Parameters (*1,*2,*3,*4,*5,*6,*7,*8,*9,*10,*11,*12)

	-30						-29					
Hexadecimal	2Dh	30h	30h	30h	33h	30h	2Dh	30h	30h	30h	32h	39h
Character	—	0	0	0	3	0	—	0	0	0	2	9
	29						30					
Hexadecimal	2Bh	30h	30h	30h	32h	39h	2Bh	30h	30h	30h	33h	30h
Character	+	0	0	0	2	9	+	0	0	0	3	0

■ Response (Callback)

In the period when the command can be accepted

Hexadecimal	02h	56h	58h	58h	3Ah	43h	43h	52h	49h	34h
Character		V	X	X	:	C	C	R	I	4
Hexadecimal	3Dh	*1	*3	*5	*7	*9	*11	03h		
Character	=	*2	*4	*6	*8	*10	*12			

Acceptability

SECURITY	STANDBY	ECO STANDBY	NO SIGNAL	SHUTTER	FREEZE	TEST PATTERN	REMOTE2	P IN P	LENS HOME
			✓	✓		✓	✓	✓	

3.147. COLOR CORRECTION - YELLOW [VXX:CCRI5]

Hexadecimal	02h	41h	44h	5Ah	5Ah	3Bh	56h	58h	58h	3Ah	43h	43h
Character		A	D	Z	Z	:	V	X	X	:	C	C
Hexadecimal	52	49h	35h	3Dh	*1	*3	*5	*7	*9	*11	03h	
Character	R	I	5	=	*2	*4	*6	*8	*10	*12		

■ Parameters (*1,*2,*3,*4,*5,*6,*7,*8,*9,*10,*11,*12)

	-30						-29					
Hexadecimal	2Dh	30h	30h	30h	33h	30h	2Dh	30h	30h	30h	32h	39h
Character	—	0	0	0	3	0	—	0	0	0	2	9
	29						30					
Hexadecimal	2Bh	30h	30h	30h	32h	39h	2Bh	30h	30h	30h	33h	30h
Character	+	0	0	0	2	9	+	0	0	0	3	0

■ Response (Callback)

In the period when the command can be accepted

Hexadecimal	02h	56h	58h	58h	3Ah	43h	43h	52h	49h	35h
Character		V	X	X	:	C	C	R	I	5
Hexadecimal	3Dh	*1	*3	*5	*7	*9	*11	03h		
Character	=	*2	*4	*6	*8	*10	*12			

Acceptability

SECURITY	STANDBY	ECO STANDBY	NO SIGNAL	SHUTTER	FREEZE	TEST PATTERN	REMOTE2	P IN P	LENS HOME
			✓	✓		✓	✓	✓	

3.148. SCREEN SETTING - SCREEN FORMAT [VSF]

Hexadecimal	02h	41h	44h	5Ah	5Ah	3Bh	56h	53h	46h	3Ah
Character		A	D	Z	Z	;	V	S	F	:
Hexadecimal	*1	03h								
Character	*2									

■ Parameters (*1,*2)

	16:10	*1	16:9	4:3	*2
Hexadecimal	30h		31h	32h	
Character	0		1	2	

*1: DX820 (FDX92C, FD605C) returns ER401.

*2: DW750 (FDW85C) returns ER401.

■ Response (Callback)

In the period when the command can be accepted

Hexadecimal	02h	56h	5h	46h	3Ah	*1	03h
Character		V	S	F	:	*2	

Acceptability

SECURITY	STANDBY	ECO STANDBY	NO SIGNAL	SHUTTER	FREEZE	TEST PATTERN	REMOTE2	P IN P	LENS HOME
			✓	✓		✓	✓	✓	

3.149. SCREEN SETTING - SCREEN POSITION - VERTICAL [VXX:VSPI0]

Hexadecimal	02h	41h	44h	5Ah	5Ah	3Bh	56h	58h	58h	3Ah
Character		A	D	Z	Z	;	V	X	X	:
Hexadecimal	56h	53h	50h	49h	30h	3Dh	*1	*3	*5	*7
Character	V	S	P	I	0	=	*2	*4	*6	*8
Hexadecimal	*9	*11	03h							
Character	*10	*12								

■ Parameters (*1,*2,*3,*4,*5,*6,*7,*8,*9,*10,*11,*12)

DZ780(FDZ88C), SCREEN FORMAT: 16:9

	-60						-59					
Hexadecimal	2Dh	30h	30h	30h	36h	30h	2Dh	30h	30h	30h	35h	39h
Character	—	0	0	0	6	0	—	0	0	0	5	9
	59						60					
Hexadecimal	2Bh	30h	30h	30h	35h	39h	2Bh	30h	30h	30h	36h	30h
Character	+	0	0	0	5	9	+	0	0	0	6	0

DW750(FDW85C), SCREEN FORMAT: 16:9

	-40						-39					
Hexadecimal	2Dh	30h	30h	30h	34h	30h	2Dh	30h	30h	30h	33h	39h
Character	—	0	0	0	4	0	—	0	0	0	3	9
	39						40					
Hexadecimal	2Bh	30h	30h	30h	33h	39h	2Bh	30h	30h	30h	34h	30h
Character	+	0	0	0	3	9	+	0	0	0	4	0

DX820(FDX92C,FD605C), SCREEN FORMAT: 16:9

	-96						-95					
Hexadecimal	2Dh	30h	30h	30h	39h	36h	2Dh	30h	30h	30h	39h	35h
Character	—	0	0	0	9	6	—	0	0	0	9	5
	95						96					
Hexadecimal	2Bh	30h	30h	30h	39h	35h	2Bh	30h	30h	30h	39h	36h
Character	+	0	0	0	9	5	+	0	0	0	9	6

■ Response (Callback)

In the period when the command can be accepted

Hexadecimal	02h	56h	58h	58h	3Ah	56h	53h	50h	49h	30h
Character		V	X	X	:	V	S	P	I	0
Hexadecimal	3Dh	*1	*3	*5	*7	*9	*11	03h		
Character	=	*2	*4	*6	*8	*10	*12			

Acceptability

SECURITY	STANDBY	ECO STANDBY	NO SIGNAL	SHUTTER	FREEZE	TEST PATTERN	REMOTE2	P IN P	LENS HOME
			✓	✓		✓	✓	✓	

■ Note:

- DZ780(FDZ88C) : When the screen format is set as [16:10] or [4:3], ER401 is returned.
- DW750(FDW85C) : When the screen format is set as [16:10], ER401 is returned.
- DX820(FDX92C,FD605C) : When the screen format is set as [4:3], ER401 is returned.

3.150. SCREEN SETTING - SCREEN POSITION - HORIZONTAL [VXX:HSP10]

Hexadecimal	02h	41h	44h	5Ah	5Ah	3Bh	56h	58h	58h	3Ah
Character		A	D	Z	Z	:	V	X	X	:
Hexadecimal	48h	53h	50h	49h	30h	3Dh	*1	*3	*5	*7
Character	H	S	P	I	0	=	*2	*4	*6	*8
Hexadecimal	*9	*11	03h							
Character	*10	*12								

■ Parameters (*1,*2,*3,*4,*5,*6,*7,*8,*9,*10,*11,*12)

DZ780(FDZ88C), SCREEN FORMAT: 4:3

	-160						-159					
Hexadecimal	2Dh	30h	30h	31h	36h	30h	2Dh	30h	30h	31h	35h	39h
Character	—	0	0	1	6	0	—	0	0	1	5	9
	159						160					
Hexadecimal	2Bh	30h	30h	31h	35h	39h	2Bh	30h	30h	31h	36h	30h
Character	+	0	0	1	5	9	+	0	0	1	6	0

■ Response (Callback)

In the period when the command can be accepted

Hexadecimal	02h	56h	58h	58h	3Ah	48h	53h	50h	49h	30h
Character		V	X	X	:	H	S	P	I	0
Hexadecimal	3Dh	*1	*3	*5	*7	*9	*11	03h		
Character	=	*2	*4	*6	*8	*10	*12			

Acceptability

SECURITY	STANDBY	ECO STANDBY	NO SIGNAL	SHUTTER	FREEZE	TEST PATTERN	REMOTE2	P IN P	LENS HOME
			✓	✓		✓	✓	✓	

■ Note:

- Only effective for DZ780(FDZ88C), other models return ER401.
- DZ780(FDZ88C) : When the screen format is set as [16:10] or [16:9], ER401 is returned.

3.151. AUTO SIGNAL [VXX:AAS10]

Hexadecimal	02h	41h	44h	5Ah	5Ah	3Bh	56h	58h	58h	3Ah
Character		A	D	Z	Z	:	V	X	X	:
Hexadecimal	41h	41h	53h	49h	30h	3Dh	2Bh	*1	*3	*5
Character	A	A	S	I	0	=	+	*2	*4	*6
Hexadecimal	*7	*9	03h							
Character	*8	*10								

■ Parameters (*1,*2,*3,*4,*5,*6,*7,*8,*9,*10)

	OFF					ON				
Hexadecimal	30h	30h	30h	30h	30h	30h	30h	30h	30h	31h
Character	0	0	0	0	0	0	0	0	0	1

■ Response (Callback)

In the period when the command can be accepted

Hexadecimal	02h	56h	58h	58h	3Ah	41h	41h	53h	49h	30h
Character		V	X	X	:	A	A	S	I	0
Hexadecimal	3Dh	2Bh	*1	*3	*5	*7	*9	03h		
Character	=	+	*2	*4	*6	*8	*10			

Acceptability

SECURITY	STANDBY	ECO STANDBY	NO SIGNAL	SHUTTER	FREEZE	TEST PATTERN	REMOTE2	P IN P	LENS HOME
			✓	✓		✓	✓	✓	

3.152. AUTO SETUP - MODE [OAM]

Hexadecimal	02h	41h	44h	5Ah	5Ah	3Bh	4Fh	41h	4Dh	3Ah
Character		A	D	Z	Z	:	O	A	M	:
Hexadecimal	*1	03h								
Character	*2									

■ Parameters (*1,*2)

	USER	DEFAULT	WIDE
Hexadecimal	30h	31h	32h
Character	0	1	2

■ Response (Callback)

In the period when the command can be accepted

Hexadecimal	02h	4Fh	41h	4Dh	3Ah	*1	03h
Character		O	A	M	:	*2	

Acceptability

SECURITY	STANDBY	ECO STANDBY	NO SIGNAL	SHUTTER	FREEZE	TEST PATTERN	REMOTE2	P IN P	LENS HOME
	✓		✓	✓	✓	✓	✓	✓	

3.153. AUTO SETUP - POSITION [VXX:APAI0]

Hexadecimal	02h	41h	44h	5Ah	5Ah	3Bh	56h	58h	58h	3Ah
Character		A	D	Z	Z	;	V	X	X	:
Hexadecimal	41h	50h	41h	49h	30h	3Dh	2Bh	*1	*3	*5
Character	A	P	A	l	0	=	+	*2	*4	*6
Hexadecimal	*7	*9	03h							
Character	*8	*10								

■ Parameters (*1,*2,*3,*4,*5,*6,*7,*8,*9,*10)

	OFF					ON				
Hexadecimal	30h	30h	30h	30h	30h	30h	30h	30h	30h	31h
Character	0	0	0	0	0	0	0	0	0	1

■ Response (Callback)

In the period when the command can be accepted

Hexadecimal	02h	56h	58h	58h	3Ah	41h	50h	41h	49h	30h
Character		V	X	X	:	A	P	A	l	0
Hexadecimal	3Dh	2Bh	*1	*3	*5	*7	*9	03h		
Character	=	+	*2	*4	*6	*8	*10			

Acceptability

SECURITY	STANDBY	ECO STANDBY	NO SIGNAL	SHUTTER	FREEZE	TEST PATTERN	REMOTE2	P IN P	LENS HOME
	✓		✓	✓	✓	✓	✓	✓	

3.154. AUTO SETUP - SIGNAL LEVEL [VXX:ASLI0]

Hexadecimal	02h	41h	44h	5Ah	5Ah	3Bh	56h	58h	58h	3Ah
Character		A	D	Z	Z	;	V	X	X	:
Hexadecimal	41h	53h	4Ch	49h	30h	3Dh	2Bh	*1	*3	*5
Character	A	S	L	l	0	=	+	*2	*4	*6
Hexadecimal	*7	*9	03h							
Character	*8	*10								

■ Parameters (*1,*2,*3,*4,*5,*6,*7,*8,*9,*10)

	OFF					ON				
Hexadecimal	30h	30h	30h	30h	30h	30h	30h	30h	30h	31h
Character	0	0	0	0	0	0	0	0	0	1

■ Response (Callback)

In the period when the command can be accepted

Hexadecimal	02h	56h	58h	58h	3Ah	41h	53h	4Ch	49h	30h
Character		V	X	X	:	A	S	L	l	0
Hexadecimal	3Dh	2Bh	*1	*3	*5	*7	*9	03h		
Character	=	+	*2	*4	*6	*8	*10			

Acceptability

SECURITY	STANDBY	ECO STANDBY	NO SIGNAL	SHUTTER	FREEZE	TEST PATTERN	REMOTE2	P IN P	LENS HOME
	✓		✓	✓	✓	✓	✓	✓	

3.155. BACKUP INPUT SETTING - BACKUP INPUT [VXX:BACI1]

Hexadecimal	02h	41h	44h	5Ah	5Ah	3Bh	56h	58h	58h	3Ah
Character		A	D	Z	Z	;	V	X	X	:
Hexadecimal	42h	41h	43h	49h	31h	3Dh	2Bh	*1	*3	*5
Character	B	A	C	l	1	=	+	*2	*4	*6
Hexadecimal	*7	*9	03h							
Character	*8	*10								

■ Parameters (*1,*2,*3,*4,*5,*6,*7,*8,*9,*10)

	Primary					Secondary				
Hexadecimal	30h	30h	30h	30h	31h	30h	30h	30h	30h	32h
Character	0	0	0	0	1	0	0	0	0	2
	Toggle									
Hexadecimal	30h	30h	30h	31h	30h					
Character	0	0	0	1	0					

■ Response (Callback)

In the period when the command can be accepted

Hexadecimal	02h	56h	58h	58h	3Ah	42h	41h	43h	49h	31h
Character		V	X	X	:	B	A	C	l	1
Hexadecimal	3Dh	2Bh	*1	*3	*5	*7	*9	03h		
Character	=	+	*2	*4	*6	*8	*10			

Acceptability

SECURITY	STANDBY	ECO STANDBY	NO SIGNAL	SHUTTER	FREEZE	TEST PATTERN	REMOTE2	P IN P	LENS HOME
				✓			✓ *		

3.156. BACKUP INPUT SETTING - BACKUP INPUT MODE [VXX:BACI2]

Hexadecimal	02h	41h	44h	5Ah	5Ah	3Bh	56h	58h	58h	3Ah
Character		A	D	Z	Z	;	V	X	X	:
Hexadecimal	42h	41h	43h	49h	32h	3Dh	2Bh	*1	*3	*5
Character	B	A	C	l	2	=	+	*2	*4	*6
Hexadecimal	*7	*9	03h							
Character	*8	*10								

■ Parameters (*1,*2,*3,*4,*5,*6,*7,*8,*9,*10)

	OFF					ON				
Hexadecimal	30h	30h	30h	30h	30h	30h	30h	30h	30h	31h
Character	0	0	0	0	0	0	0	0	0	1

■ Response (Callback)

In the period when the command can be accepted

Hexadecimal	02h	56h	58h	58h	3Ah	42h	41h	43h	49h	32h
Character		V	X	X	:	B	A	C	l	2
Hexadecimal	3Dh	2Bh	*1	*3	*5	*7	*9	03h		
Character	=	+	*2	*4	*6	*8	*10			

Acceptability

SECURITY	STANDBY	ECO STANDBY	NO SIGNAL	SHUTTER	FREEZE	TEST PATTERN	REMOTE2	P IN P	LENS HOME
	✓		✓	✓		✓	✓		

3.157. BACKUP INPUT SETTING - AUTOMATIC SWITCHING [VXX:BACI3]

Hexadecimal	02h	41h	44h	5Ah	5Ah	3Bh	56h	58h	58h	3Ah
Character		A	D	Z	Z	;	V	X	X	:
Hexadecimal	42h	41h	43h	49h	33h	3Dh	2Bh	*1	*3	*5
Character	B	A	C	l	3	=	+	*2	*4	*6
Hexadecimal	*7	*9	03h							
Character	*8	*10								

■ Parameters (*1,*2,*3,*4,*5,*6,*7,*8,*9,*10)

	DISABLE					ENABLE				
Hexadecimal	30h	30h	30h	30h	30h	30h	30h	30h	30h	31h
Character	0	0	0	0	0	0	0	0	0	1

■ Response (Callback)

In the period when the command can be accepted

Hexadecimal	02h	56h	58h	58h	3Ah	42h	41h	43h	49h	33h
Character		V	X	X	:	B	A	C	l	3
Hexadecimal	3Dh	2Bh	*1	*3	*5	*7	*9	03h		
Character	=	+	*2	*4	*6	*8	*10			

Acceptability

SECURITY	STANDBY	ECO STANDBY	NO SIGNAL	SHUTTER	FREEZE	TEST PATTERN	REMOTE2	P IN P	LENS HOME
	✓		✓	✓		✓	✓		

3.158. RGB IN - RGB1 INPUT SETTING [VXX:RYCI1]

Hexadecimal	02h	41h	44h	5Ah	5Ah	3Bh	56h	58h	58h	3Ah
Character		A	D	Z	Z	;	V	X	X	:
Hexadecimal	52h	59h	43h	49h	31h	3Dh	2Bh	*1	*3	*5
Character	R	Y	C	l	1	=	+	*2	*4	*6
Hexadecimal	*7	*9	03h							
Character	*8	*10								

■ Parameters (*1,*2,*3,*4,*5,*6,*7,*8,*9,*10)

	RGB/YBPBR					Y/C				
Hexadecimal	30h	30h	30h	30h	30h	30h	30h	30h	30h	31h
Character	0	0	0	0	0	0	0	0	0	1
	VIDEO									
Hexadecimal	30h	30h	30h	30h	32h					
Character	0	0	0	0	2					

■ Response (Callback)

In the period when the command can be accepted

Hexadecimal	02h	56h	58h	58h	3Ah	52h	59h	43h	49h	31h
Character		V	X	X	:	R	Y	C	l	1
Hexadecimal	3Dh	2Bh	*1	*3	*5	*7	*9	03h		
Character	=	+	*2	*4	*6	*8	*10			

Acceptability

SECURITY	STANDBY	ECO STANDBY	NO SIGNAL	SHUTTER	FREEZE	TEST PATTERN	REMOTE2	P IN P	LENS HOME
			✓	✓		✓	✓	✓	

3.159. RGB IN - RGB1 SYNC SLICE LEVEL [VXX:STRI0]

Hexadecimal	02h	41h	44h	5Ah	5Ah	3Bh	56h	58h	58h	3Ah
Character		A	D	Z	Z	;	V	X	X	:
Hexadecimal	53h	54h	52h	49h	30h	3Dh	2Bh	*1	*3	*5
Character	S	T	R	l	0	=	+	*2	*4	*6
Hexadecimal	*7	*9	03h							
Character	*8	*10								

■ Parameters (*1,*2,*3,*4,*5,*6,*7,*8,*9,*10)

	LOW					HIGH				
Hexadecimal	30h	30h	30h	30h	30h	30h	30h	30h	30h	31h
Character	0	0	0	0	0	0	0	0	0	1

■ Response (Callback)

In the period when the command can be accepted

Hexadecimal	02h	56h	58h	58h	3Ah	53h	54h	52h	49h	30h
Character		V	X	X	:	S	T	R	l	0
Hexadecimal	3Dh	2Bh	*1	*3	*5	*7	*9	03h		
Character	=	+	*2	*4	*6	*8	*10			

Acceptability

SECURITY	STANDBY	ECO STANDBY	NO SIGNAL	SHUTTER	FREEZE	TEST PATTERN	REMOTE2	P IN P	LENS HOME
✓	✓		✓	✓	✓	✓	✓	✓	✓

3.160. RGB IN - RGB2 SYNC SLICE LEVEL [VXX:STRI1]

Hexadecimal	02h	41h	44h	5Ah	5Ah	3Bh	56h	58h	58h	3Ah
Character		A	D	Z	Z	;	V	X	X	:
Hexadecimal	53h	54h	52h	49h	31h	3Dh	2Bh	*1	*3	*5
Character	S	T	R	l	1	=	+	*2	*4	*6
Hexadecimal	*7	*9	03h							
Character	*8	*10								

■ Parameters (*1,*2,*3,*4,*5,*6,*7,*8,*9,*10)

	LOW					HIGH				
Hexadecimal	30h	30h	30h	30h	30h	30h	30h	30h	30h	31h
Character	0	0	0	0	0	0	0	0	0	1

■ Response (Callback)

In the period when the command can be accepted

Hexadecimal	02h	56h	58h	58h	3Ah	53h	54h	52h	49h	31h
Character		V	X	X	:	S	T	R	l	1
Hexadecimal	3Dh	2Bh	*1	*3	*5	*7	*9	03h		
Character	=	+	*2	*4	*6	*8	*10			

Acceptability

SECURITY	STANDBY	ECO STANDBY	NO SIGNAL	SHUTTER	FREEZE	TEST PATTERN	REMOTE2	P IN P	LENS HOME
✓	✓		✓	✓	✓	✓	✓	✓	✓

3.161. RGB IN - RGB2 EDID MODE [VXX:EDMI1]

Hexadecimal	02h	41h	44h	5Ah	5Ah	3Bh	56h	58h	58h	3Ah
Character		A	D	Z	Z	;	V	X	X	:
Hexadecimal	45h	44h	4Dh	49h	31h	3Dh	2Bh	*1	*3	*5
Character	E	D	M	l	1	=	+	*2	*4	*6
Hexadecimal	*7	*9	03h							
Character	*8	*10								

■ Parameters (*1,*2,*3,*4,*5,*6,*7,*8,*9,*10)

	DEFAULT					SCREEN FIT				
Hexadecimal	30h	30h	30h	30h	30h	30h	30h	30h	30h	31h
Character	0	0	0	0	0	0	0	0	0	1
	USER									
Hexadecimal	30h	30h	30h	31h	30h					
Character	0	0	0	1	0					

■ Response (Callback)

In the period when the command can be accepted

Hexadecimal	02h	56h	58h	58h	3Ah	45h	44h	4Dh	49h	31h
Character		V	X	X	:	E	D	M	l	1
Hexadecimal	3Dh	2Bh	*1	*3	*5	*7	*9	03h		
Character	=	+	*2	*4	*6	*8	*10			

Acceptability

SECURITY	STANDBY	ECO STANDBY	NO SIGNAL	SHUTTER	FREEZE	TEST PATTERN	REMOTE2	P IN P	LENS HOME
			✓	✓		✓	✓	✓	

3.162. RGB IN - RGB2 EDID RESOLUTION [VXX:EDRS1]

Hexadecimal	02h	41h	44h	5Ah	5Ah	3Bh	56h	58h	58h	3Ah
Character		A	D	Z	Z	;	V	X	X	:
Hexadecimal	45h	44h	52h	53h	31h	3Dh	*1	*3	*5	*7
Character	E	D	R	S	1	=	*2	*4	*6	*8
Hexadecimal	*9	*11	*13	*15	*17	*19	*21	03h		
Character	*10	*12	*14	*16	*18	*20	*22			

■ Parameters (*1,*2,*3,*4,*5,*6,*7,*8,*9,*10,...,*21,*22)

1024x768p											
Hexadecimal	31h	30h	32h	34h	3Ah	30h	37h	36h	38h	3Ah	70h
Character	1	0	2	4	:	0	7	6	8	:	p
1280x720p											
Hexadecimal	31h	30h	32h	34h	3Ah	30h	37h	32h	30h	3Ah	70h
Character	1	2	8	0	:	0	7	2	0	:	p
1280x768p											
Hexadecimal	31h	30h	32h	34h	3Ah	30h	37h	36h	38h	3Ah	70h
Character	1	2	8	0	:	0	7	6	8	:	p
1280x800p											
Hexadecimal	31h	30h	32h	34h	3Ah	30h	38h	30h	30h	3Ah	70h
Character	1	2	8	0	:	0	8	0	0	:	p
1280x1024p											
Hexadecimal	31h	30h	32h	34h	3Ah	31h	30h	32h	34h	3Ah	70h
Character	1	2	8	0	:	1	0	2	4	:	p
1366x768p											
Hexadecimal	31h	33h	36h	36h	3Ah	30h	37h	36h	38h	3Ah	70h
Character	1	3	6	6	:	0	7	6	8	:	p
1400x1050p											
Hexadecimal	31h	34h	30h	30h	3Ah	31h	30h	35h	30h	3Ah	70h
Character	1	4	0	0	:	1	0	5	0	:	p
1440x900p											
Hexadecimal	31h	34h	34h	30h	3Ah	30h	39h	30h	30h	3Ah	70h
Character	1	4	4	0	:	0	9	0	0	:	p
1600x900p											
Hexadecimal	31h	36h	30h	30h	3Ah	30h	39h	30h	30h	3Ah	70h
Character	1	6	0	0	:	0	9	0	0	:	p
1600x1200p											
Hexadecimal	31h	36h	30h	30h	3Ah	31h	32h	30h	30h	3Ah	70h
Character	1	6	0	0	:	1	2	0	0	:	p
1680x1050p											
Hexadecimal	31h	36h	38h	30h	3Ah	31h	30h	35h	30h	3Ah	70h
Character	1	6	8	0	:	1	0	5	0	:	p
1920x1080p											
Hexadecimal	31h	39h	32h	30h	3Ah	31h	30h	38h	30h	3Ah	70h
Character	1	9	2	0	:	1	0	8	0	:	p
1920x1080i											
Hexadecimal	31h	39h	32h	30h	3Ah	30h	30h	38h	30h	3Ah	69h
Character	1	9	2	0	:	1	0	8	0	:	i
1920x1200p											
Hexadecimal	31h	39h	32h	30h	3Ah	31h	30h	30h	30h	3Ah	70h
Character	1	9	2	0	:	1	2	0	0	:	p

■ Response (Callback)

In the period when the command can be accepted

Hexadecimal	02h	56h	58h	58h	3Ah	45h	44h	52h	53h	31h
Character		V	X	X	:	E	D	R	S	1
Hexadecimal	3Dh	2Bh	*1	*3	*5	*7	*9	03h		
Character	=	+	*2	*4	*6	*8	*10			

Acceptability

SECURITY	STANDBY	ECO STANDBY	NO SIGNAL	SHUTTER	FREEZE	TEST PATTERN	REMOTE2	P IN P	LENS HOME
			✓	✓		✓	✓	✓	

3.163. RGB IN - RGB2 EDID VERTICAL SCAN FREQUENCY [VXX: EDV11]

Hexadecimal	02h	41h	44h	5Ah	5Ah	3Bh	56h	58h	58h	3Ah
Character		A	D	Z	Z	;	V	X	X	:
Hexadecimal	45h	44h	56h	49h	31h	3Dh	2Bh	*1	*3	*5
Character	E	D	V	I	1	=	+	*2	*4	*6
Hexadecimal	*7	*9	03h							
Character	*8	*10								

■ Parameters (*1,*2,*3,*4,*5,*6,*7,*8,*9,*10)

	60Hz					50Hz				
Hexadecimal	30h	36h	30h	30h	30h	30h	35h	30h	30h	30h
Character	0	6	0	0	0	0	5	0	0	0
	48Hz					30Hz				
Hexadecimal	30h	34h	38h	30h	30h	30h	33h	30h	30h	30h
Character	0	4	8	0	0	0	3	0	0	0
	25Hz					24Hz				
Hexadecimal	30h	32h	35h	30h	30h	30h	32h	34h	30h	30h
Character	0	2	5	0	0	0	2	4	0	0

■ Response (Callback)

In the period when the command can be accepted

Hexadecimal	02h	56h	58h	58h	3Ah	45h	44h	56h	49h	31h
Character		V	X	X	:	E	D	V	I	1
Hexadecimal	3Dh	2Bh	*1	*3	*5	*7	*9	03h		
Character	=	+	*2	*4	*6	*8	*10			

Acceptability

SECURITY	STANDBY	ECO STANDBY	NO SIGNAL	SHUTTER	FREEZE	TEST PATTERN	REMOTE2	P IN P	LENS HOME
			✓	✓		✓	✓	✓	

3.164. DVI-D IN - EDID [OED]

Hexadecimal	02h	41h	44h	5Ah	5Ah	3Bh	4Fh	45h	44h	3Ah
Character		A	D	Z	Z	;	O	E	D	:
Hexadecimal	*1	03h								
Character	*2									

■ Parameters (*1,*2)

	EDID1	EDID2 (PC)	EDID3
Hexadecimal	31h	32h	33h
Character	1	2	3

■ Response (Callback)

In the period when the command can be accepted

Hexadecimal	02h	4Fh	45h	44h	3Ah	*1	03h
Character		O	E	D	:	*2	

Acceptability

SECURITY	STANDBY	ECO STANDBY	NO SIGNAL	SHUTTER	FREEZE	TEST PATTERN	REMOTE2	P IN P	LENS HOME
	✓		✓	✓		✓	✓	✓	

3.165. DVI-D IN - SIGNAL LEVEL [VXX:DVII0]

Hexadecimal	02h	41h	44h	5Ah	5Ah	3Bh	56h	58h	58h	3Ah
Character		A	D	Z	Z	;	V	X	X	:
Hexadecimal	44h	56h	49h	49h	30h	3Dh	2Bh	*1	*3	*5
Character	D	V	I	I	0	=	+	*2	*4	*6
Hexadecimal	*7	*9	03h							
Character	*8	*10								

■ Parameters (*1,*2,*3,*4,*5,*6,*7,*8,*9,*10)

	0-255:PC					16-235					AUTO				
Hexadecimal	30h	30h	30h	30h	30h	30h	30h	30h	30h	31h	30h	30h	30h	30h	32h
Character	0	0	0	0	0	0	0	0	0	1	0	0	0	0	2

■ Response (Callback)

In the period when the command can be accepted

Hexadecimal	02h	56h	58h	58h	3Ah	44h	56h	49h	49h	30h
Character		V	X	X	:	D	V	I	I	0
Hexadecimal	3Dh	2Bh	*1	*3	*5	*7	*9	03h		
Character	=	+	*2	*4	*6	*8	*10			

Acceptability

SECURITY	STANDBY	ECO STANDBY	NO SIGNAL	SHUTTER	FREEZE	TEST PATTERN	REMOTE2	P IN P	LENS HOME
			✓	✓		✓	✓	✓	

3.166. DVI-D IN - EDID MODE [VXX:EDMI2]

Hexadecimal	02h	41h	44h	5Ah	5Ah	3Bh	56h	58h	58h	3Ah
Character		A	D	Z	Z	;	V	X	X	:
Hexadecimal	45h	44h	4Dh	49h	32h	3Dh	2Bh	*1	*3	*5
Character	E	D	M	I	2	=	+	*2	*4	*6
Hexadecimal	*7	*9	03h							
Character	*8	*10								

■ Parameters (*1,*2,*3,*4,*5,*6,*7,*8,*9,*10)

	DEFAULT					SCREEN FIT				
Hexadecimal	30h	30h	30h	30h	30h	30h	30h	30h	30h	31h
Character	0	0	0	0	0	0	0	0	0	1
	USER									
Hexadecimal	30h	30h	30h	31h	30h					
Character	0	0	0	1	0					

■ Response (Callback)

In the period when the command can be accepted

Hexadecimal	02h	56h	58h	58h	3Ah	45h	44h	4Dh	49h	32h
Character		V	X	X	:	E	D	M	I	2
Hexadecimal	3Dh	2Bh	*1	*3	*5	*7	*9	03h		
Character	=	+	*2	*4	*6	*8	*10			

Acceptability

SECURITY	STANDBY	ECO STANDBY	NO SIGNAL	SHUTTER	FREEZE	TEST PATTERN	REMOTE2	P IN P	LENS HOME
			✓	✓		✓	✓	✓	

3.167. DVI-D IN - EDID RESOLUTION [VXX:EDRS2]

Hexadecimal	02h	41h	44h	5Ah	5Ah	3Bh	56h	58h	58h	3Ah
Character		A	D	Z	Z	;	V	X	X	:
Hexadecimal	45h	44h	52h	53h	32h	3Dh	*1	*3	*5	*7
Character	E	D	R	S	2	=	*2	*4	*6	*8
Hexadecimal	*9	*11	*13	*15	*17	*19	*21	03h		
Character	*10	*12	*14	*16	*18	*20	*22			

■ Parameters (*1,*2,*3,*4,*5,*6,*7,*8,*9,*10,...,*21,*22)

	1024x768p										
Hexadecimal	31h	30h	32h	34h	3Ah	30h	37h	36h	38h	3Ah	70h
Character	1	0	2	4	:	0	7	6	8	:	p
	1280x720p										
Hexadecimal	31h	30h	32h	34h	3Ah	30h	37h	32h	30h	3Ah	70h
Character	1	2	8	0	:	0	7	2	0	:	p
	1280x768p										
Hexadecimal	31h	30h	32h	34h	3Ah	30h	37h	36h	38h	3Ah	70h
Character	1	2	8	0	:	0	7	6	8	:	p
	1280x800p										
Hexadecimal	31h	30h	32h	34h	3Ah	30h	38h	30h	30h	3Ah	70h
Character	1	2	8	0	:	0	8	0	0	:	p
	1280x1024p										
Hexadecimal	31h	30h	32h	34h	3Ah	31h	30h	32h	34h	3Ah	70h
Character	1	2	8	0	:	1	0	2	4	:	p
	1366x768p										
Hexadecimal	31h	33h	36h	36h	3Ah	30h	37h	36h	38h	3Ah	70h
Character	1	3	6	6	:	0	7	6	8	:	p
	1400x1050p										
Hexadecimal	31h	34h	30h	30h	3Ah	31h	30h	35h	30h	3Ah	70h
Character	1	4	0	0	:	1	0	5	0	:	p
	1440x900p										
Hexadecimal	31h	34h	34h	30h	3Ah	30h	39h	30h	30h	3Ah	70h
Character	1	4	4	0	:	0	9	0	0	:	p
	1600x900p										
Hexadecimal	31h	36h	30h	30h	3Ah	30h	39h	30h	30h	3Ah	70h
Character	1	6	0	0	:	0	9	0	0	:	p
	1600x1200p										
Hexadecimal	31h	36h	30h	30h	3Ah	31h	32h	30h	30h	3Ah	70h
Character	1	6	0	0	:	1	2	0	0	:	p
	1680x1050p										
Hexadecimal	31h	36h	38h	30h	3Ah	31h	30h	35h	30h	3Ah	70h
Character	1	6	8	0	:	1	0	5	0	:	p
	1920x1080p										
Hexadecimal	31h	39h	32h	30h	3Ah	31h	30h	38h	30h	3Ah	70h
Character	1	9	2	0	:	1	0	8	0	:	p

	1920x1080i										
Hexadecimal	31h	39h	32h	30h	3Ah	30h	30h	38h	30h	3Ah	69h
Character	1	9	2	0	:	1	0	8	0	:	i
	1920x1200p										
Hexadecimal	31h	39h	32h	30h	3Ah	31h	30h	30h	30h	3Ah	70h
Character	1	9	2	0	:	1	2	0	0	:	p

■ Response (Callback)

In the period when the command can be accepted

Hexadecimal	02h	56h	58h	58h	3Ah	45h	44h	52h	53h	32h
Character		V	X	X	:	E	D	R	S	2
Hexadecimal	3Dh	2Bh	*1	*3	*5	*7	*9	03h		
Character	=	+	*2	*4	*6	*8	*10			

Acceptability

SECURITY	STANDBY	ECO STANDBY	NO SIGNAL	SHUTTER	FREEZE	TEST PATTERN	REMOTE2	P IN P	LENS HOME
			✓	✓		✓	✓	✓	

3.168. DVI-D IN - EDID VERTICAL SCAN FREQUENCY [VXX: EDVI2]

Hexadecimal	02h	41h	44h	5Ah	5Ah	3Bh	56h	58h	58h	3Ah
Character		A	D	Z	Z	;	V	X	X	:
Hexadecimal	45h	44h	56h	49h	32h	3Dh	2Bh	*1	*3	*5
Character	E	D	V	I	2	=	+	*2	*4	*6
Hexadecimal	*7	*9	03h							
Character	*8	*10								

■ Parameters (*1,*2,*3,*4,*5,*6,*7,*8,*9,*10)

	60Hz					50Hz				
Hexadecimal	30h	36h	30h	30h	30h	30h	35h	30h	30h	30h
Character	0	6	0	0	0	0	5	0	0	0
	48Hz					30Hz				
Hexadecimal	30h	34h	38h	30h	30h	30h	33h	30h	30h	30h
Character	0	4	8	0	0	0	3	0	0	0
	25Hz					24Hz				
Hexadecimal	30h	32h	35h	30h	30h	30h	32h	34h	30h	30h
Character	0	2	5	0	0	0	2	4	0	0

■ Response (Callback)

In the period when the command can be accepted

Hexadecimal	02h	56h	58h	58h	3Ah	45h	44h	56h	49h	32h
Character		V	X	X	:	E	D	V	I	2
Hexadecimal	3Dh	2Bh	*1	*3	*5	*7	*9	03h		
Character	=	+	*2	*4	*6	*8	*10			

Acceptability

SECURITY	STANDBY	ECO STANDBY	NO SIGNAL	SHUTTER	FREEZE	TEST PATTERN	REMOTE2	P IN P	LENS HOME
			✓	✓		✓	✓	✓	

3.169. HDMI IN - SIGNAL LEVEL [VXX:HSLI0]

Hexadecimal	02h	41h	44h	5Ah	5Ah	3Bh	56h	58h	58h	3Ah
Character		A	D	Z	Z	;	V	X	X	:
Hexadecimal	48h	53h	4Ch	49h	30h	3Dh	2Bh	*1	*3	*5
Character	H	S	L	I	0	=	+	*2	*4	*6
Hexadecimal	*7	*9	03h							
Character	*8	*10								

■ Parameters (*1,*2,*3,*4,*5,*6,*7,*8,*9,*10)

	0-1023					64-940					AUTO				
Hexadecimal	30h	30h	30h	30h	30h	30h	30h	30h	30h	31h	30h	30h	30h	30h	32h
Character	0	0	0	0	0	0	0	0	0	1	0	0	0	0	2

■ Response (Callback)

In the period when the command can be accepted

Hexadecimal	02h	56h	58h	58h	3Ah	48h	53h	4Ch	49h	30h
Character		V	X	X	:	H	S	L	I	0
Hexadecimal	3Dh	2Bh	*1	*3	*5	*7	*9	03h		
Character	=	+	*2	*4	*6	*8	*10			

Acceptability

SECURITY	STANDBY	ECO STANDBY	NO SIGNAL	SHUTTER	FREEZE	TEST PATTERN	REMOTE2	P IN P	LENS HOME
			✓	✓		✓	✓	✓	

3.170. HDMI IN - EDID MODE [VXX:EDMI3]

Hexadecimal	02h	41h	44h	5Ah	5Ah	3Bh	56h	58h	58h	3Ah
Character		A	D	Z	Z	;	V	X	X	:
Hexadecimal	45h	44h	4Dh	49h	33h	3Dh	2Bh	*1	*3	*5
Character	E	D	M	I	3	=	+	*2	*4	*6
Hexadecimal	*7	*9	03h							
Character	*8	*10								

■ Parameters (*1,*2,*3,*4,*5,*6,*7,*8,*9,*10)

	DEFAULT					SCREEN FIT				
Hexadecimal	30h	30h	30h	30h	30h	30h	30h	30h	30h	31h
Character	0	0	0	0	0	0	0	0	0	1
	USER									
Hexadecimal	30h	30h	30h	31h	30h					
Character	0	0	0	1	0					

■ Response (Callback)

In the period when the command can be accepted

Hexadecimal	02h	56h	58h	58h	3Ah	45h	44h	4Dh	49h	33h
Character		V	X	X	:	E	D	M	I	3
Hexadecimal	3Dh	2Bh	*1	*3	*5	*7	*9	03h		
Character	=	+	*2	*4	*6	*8	*10			

Acceptability

SECURITY	STANDBY	ECO STANDBY	NO SIGNAL	SHUTTER	FREEZE	TEST PATTERN	REMOTE2	P IN P	LENS HOME
			✓	✓		✓	✓	✓	

3.171. HDMI IN - EDID RESOLUTION [VXX:EDRS3]

Hexadecimal	02h	41h	44h	5Ah	5Ah	3Bh	56h	58h	58h	3Ah
Character		A	D	Z	Z	;	V	X	X	:
Hexadecimal	45h	44h	52h	53h	33h	3Dh	*1	*3	*5	*7
Character	E	D	R	S	3	=	*2	*4	*6	*8
Hexadecimal	*9	*11	*13	*15	*17	*19	*21	03h		
Character	*10	*12	*14	*16	*18	*20	*22			

■ Parameters (*1,*2,*3,*4,*5,*6,*7,*8,*9,*10,...,*21,*22)

1024x768p											
Hexadecimal	31h	30h	32h	34h	3Ah	30h	37h	36h	38h	3Ah	70h
Character	1	0	2	4	:	0	7	6	8	:	p
1280x720p											
Hexadecimal	31h	30h	32h	34h	3Ah	30h	37h	32h	30h	3Ah	70h
Character	1	2	8	0	:	0	7	2	0	:	p
1280x768p											
Hexadecimal	31h	30h	32h	34h	3Ah	30h	37h	36h	38h	3Ah	70h
Character	1	2	8	0	:	0	7	6	8	:	p
1280x800p											
Hexadecimal	31h	30h	32h	34h	3Ah	30h	38h	30h	30h	3Ah	70h
Character	1	2	8	0	:	0	8	0	0	:	p
1280x1024p											
Hexadecimal	31h	30h	32h	34h	3Ah	31h	30h	32h	34h	3Ah	70h
Character	1	2	8	0	:	1	0	2	4	:	p
1366x768p											
Hexadecimal	31h	33h	36h	36h	3Ah	30h	37h	36h	38h	3Ah	70h
Character	1	3	6	6	:	0	7	6	8	:	p
1400x1050p											
Hexadecimal	31h	34h	30h	30h	3Ah	31h	30h	35h	30h	3Ah	70h
Character	1	4	0	0	:	1	0	5	0	:	p
1440x900p											
Hexadecimal	31h	34h	34h	30h	3Ah	30h	39h	30h	30h	3Ah	70h
Character	1	4	4	0	:	0	9	0	0	:	p
1600x900p											
Hexadecimal	31h	36h	30h	30h	3Ah	30h	39h	30h	30h	3Ah	70h
Character	1	6	0	0	:	0	9	0	0	:	p
1600x1200p											
Hexadecimal	31h	36h	30h	30h	3Ah	31h	32h	30h	30h	3Ah	70h
Character	1	6	0	0	:	1	2	0	0	:	p
1680x1050p											
Hexadecimal	31h	36h	38h	30h	3Ah	31h	30h	35h	30h	3Ah	70h
Character	1	6	8	0	:	1	0	5	0	:	p
1920x1080p											
Hexadecimal	31h	39h	32h	30h	3Ah	31h	30h	38h	30h	3Ah	70h
Character	1	9	2	0	:	1	0	8	0	:	p

	1920x1080i										
Hexadecimal	31h	39h	32h	30h	3Ah	30h	30h	38h	30h	3Ah	69h
Character	1	9	2	0	:	1	0	8	0	:	i
	1920x1200p										
Hexadecimal	31h	39h	32h	30h	3Ah	31h	30h	30h	30h	3Ah	70h
Character	1	9	2	0	:	1	2	0	0	:	p

■ Response (Callback)

In the period when the command can be accepted

Hexadecimal	02h	56h	58h	58h	3Ah	45h	44h	52h	53h	33h
Character		V	X	X	:	E	D	R	S	3
Hexadecimal	3Dh	2Bh	*1	*3	*5	*7	*9	03h		
Character	=	+	*2	*4	*6	*8	*10			

Acceptability

SECURITY	STANDBY	ECO STANDBY	NO SIGNAL	SHUTTER	FREEZE	TEST PATTERN	REMOTE2	P IN P	LENS HOME
			✓	✓		✓	✓	✓	

3.172. HDMI IN - EDID VERTICAL SCAN FREQUENCY [VXX: EDVI3]

Hexadecimal	02h	41h	44h	5Ah	5Ah	3Bh	56h	58h	58h	3Ah
Character		A	D	Z	Z	;	V	X	X	:
Hexadecimal	45h	44h	56h	49h	33h	3Dh	2Bh	*1	*3	*5
Character	E	D	V	l	3	=	+	*2	*4	*6
Hexadecimal	*7	*9	03h							
Character	*8	*10								

■ Parameters (*1,*2,*3,*4,*5,*6,*7,*8,*9,*10)

	60Hz					50Hz				
Hexadecimal	30h	36h	30h	30h	30h	30h	35h	30h	30h	30h
Character	0	6	0	0	0	0	5	0	0	0
	48Hz					30Hz				
Hexadecimal	30h	34h	38h	30h	30h	30h	33h	30h	30h	30h
Character	0	4	8	0	0	0	3	0	0	0
	25Hz					24Hz				
Hexadecimal	30h	32h	35h	30h	30h	30h	32h	34h	30h	30h
Character	0	2	5	0	0	0	2	4	0	0

■ Response (Callback)

In the period when the command can be accepted

Hexadecimal	02h	56h	58h	58h	3Ah	45h	44h	56h	49h	33h
Character		V	X	X	:	E	D	V	l	3
Hexadecimal	3Dh	2Bh	*1	*3	*5	*7	*9	03h		
Character	=	+	*2	*4	*6	*8	*10			

Acceptability

SECURITY	STANDBY	ECO STANDBY	NO SIGNAL	SHUTTER	FREEZE	TEST PATTERN	REMOTE2	P IN P	LENS HOME
			✓	✓		✓	✓	✓	

3.173. DIGITAL LINK IN - SIGNAL LEVEL [VXX:DKL11]

Hexadecimal	02h	41h	44h	5Ah	5Ah	3Bh	56h	58h	58h	3Ah
Character		A	D	Z	Z	;	V	X	X	:
Hexadecimal	44h	4Bh	4Ch	49h	31h	3Dh	2Bh	*1	*3	*5
Character	D	K	L	l	1	=	+	*2	*4	*6
Hexadecimal	*7	*9	03h							
Character	*8	*10								

■ Parameters (*1,*2,*3,*4,*5,*6,*7,*8,*9,*10)

	AUTO					0-1023					64-940				
Hexadecimal	30h	30h	30h	30h	30h	30h	30h	30h	30h	31h	30h	30h	30h	30h	32h
Character	0	0	0	0	0	0	0	0	0	1	0	0	0	0	2

■ Response (Callback)

In the period when the command can be accepted

Hexadecimal	02h	56h	58h	58h	3Ah	44h	4Bh	4Ch	49h	31h
Character		V	X	X	:	D	K	L	l	1
Hexadecimal	3Dh	2Bh	*1	*3	*5	*7	*9	03h		
Character	=	+	*2	*4	*6	*8	*10			

Acceptability

SECURITY	STANDBY	ECO STANDBY	NO SIGNAL	SHUTTER	FREEZE	TEST PATTERN	REMOTE2	P IN P	LENS HOME
			✓	✓		✓	✓	✓	

3.174. DIGITAL LINK IN - EDID MODE [VXX:EDMI4]

Hexadecimal	02h	41h	44h	5Ah	5Ah	3Bh	56h	58h	58h	3Ah
Character		A	D	Z	Z	;	V	X	X	:
Hexadecimal	45h	44h	4Dh	49h	34h	3Dh	2Bh	*1	*3	*5
Character	E	D	M	I	4	=	+	*2	*4	*6
Hexadecimal	*7	*9	03h							
Character	*8	*10								

■ Parameters (*1,*2,*3,*4,*5,*6,*7,*8,*9,*10)

	DEFAULT					SCREEN FIT				
Hexadecimal	30h	30h	30h	30h	30h	30h	30h	30h	30h	31h
Character	0	0	0	0	0	0	0	0	0	1
	USER									
Hexadecimal	30h	30h	30h	31h	30h					
Character	0	0	0	1	0					

■ Response (Callback)

In the period when the command can be accepted

Hexadecimal	02h	56h	58h	58h	3Ah	45h	44h	4Dh	49h	34h
Character		V	X	X	:	E	D	M	I	4
Hexadecimal	3Dh	2Bh	*1	*3	*5	*7	*9	03h		
Character	=	+	*2	*4	*6	*8	*10			

Acceptability

SECURITY	STANDBY	ECO STANDBY	NO SIGNAL	SHUTTER	FREEZE	TEST PATTERN	REMOTE2	P IN P	LENS HOME
			✓	✓		✓	✓	✓	

3.175. DIGITAL LINK IN - EDID RESOLUTION [VXX:EDRS4]

Hexadecimal	02h	41h	44h	5Ah	5Ah	3Bh	56h	58h	58h	3Ah
Character		A	D	Z	Z	;	V	X	X	:
Hexadecimal	45h	44h	52h	53h	34h	3Dh	*1	*3	*5	*7
Character	E	D	R	S	4	=	*2	*4	*6	*8
Hexadecimal	*9	*11	*13	*15	*17	*19	*21	03h		
Character	*10	*12	*14	*16	*18	*20	*22			

■ Parameters (*1,*2,*3,*4,*5,*6,*7,*8,*9,*10,...,*21,*22)

1024x768p											
Hexadecimal	31h	30h	32h	34h	3Ah	30h	37h	36h	38h	3Ah	70h
Character	1	0	2	4	:	0	7	6	8	:	p
1280x720p											
Hexadecimal	31h	30h	32h	34h	3Ah	30h	37h	32h	30h	3Ah	70h
Character	1	2	8	0	:	0	7	2	0	:	p
1280x768p											
Hexadecimal	31h	30h	32h	34h	3Ah	30h	37h	36h	38h	3Ah	70h
Character	1	2	8	0	:	0	7	6	8	:	p
1280x800p											
Hexadecimal	31h	30h	32h	34h	3Ah	30h	38h	30h	30h	3Ah	70h
Character	1	2	8	0	:	0	8	0	0	:	p
1280x1024p											
Hexadecimal	31h	30h	32h	34h	3Ah	31h	30h	32h	34h	3Ah	70h
Character	1	2	8	0	:	1	0	2	4	:	p
1366x768p											
Hexadecimal	31h	33h	36h	36h	3Ah	30h	37h	36h	38h	3Ah	70h
Character	1	3	6	6	:	0	7	6	8	:	p
1400x1050p											
Hexadecimal	31h	34h	30h	30h	3Ah	31h	30h	35h	30h	3Ah	70h
Character	1	4	0	0	:	1	0	5	0	:	p
1440x900p											
Hexadecimal	31h	34h	34h	30h	3Ah	30h	39h	30h	30h	3Ah	70h
Character	1	4	4	0	:	0	9	0	0	:	p
1600x900p											
Hexadecimal	31h	36h	30h	30h	3Ah	30h	39h	30h	30h	3Ah	70h
Character	1	6	0	0	:	0	9	0	0	:	p
1600x1200p											
Hexadecimal	31h	36h	30h	30h	3Ah	31h	32h	30h	30h	3Ah	70h
Character	1	6	0	0	:	1	2	0	0	:	p
1680x1050p											
Hexadecimal	31h	36h	38h	30h	3Ah	31h	30h	35h	30h	3Ah	70h
Character	1	6	8	0	:	1	0	5	0	:	p
1920x1080p											
Hexadecimal	31h	39h	32h	30h	3Ah	31h	30h	38h	30h	3Ah	70h
Character	1	9	2	0	:	1	0	8	0	:	p

	1920x1080i										
Hexadecimal	31h	39h	32h	30h	3Ah	30h	30h	38h	30h	3Ah	69h
Character	1	9	2	0	:	1	0	8	0	:	i
	1920x1200p										
Hexadecimal	31h	39h	32h	30h	3Ah	31h	30h	30h	30h	3Ah	70h
Character	1	9	2	0	:	1	2	0	0	:	p

■ Response (Callback)

In the period when the command can be accepted

Hexadecimal	02h	56h	58h	58h	3Ah	45h	44h	52h	53h	34h
Character		V	X	X	:	E	D	R	S	4
Hexadecimal	3Dh	2Bh	*1	*3	*5	*7	*9	03h		
Character	=	+	*2	*4	*6	*8	*10			

Acceptability

SECURITY	STANDBY	ECO STANDBY	NO SIGNAL	SHUTTER	FREEZE	TEST PATTERN	REMOTE2	P IN P	LENS HOME
			✓	✓		✓	✓	✓	

3.176. DIGITAL LINK IN - EDID VERTICAL SCAN FREQUENCY [VXX: EDVI4]

Hexadecimal	02h	41h	44h	5Ah	5Ah	3Bh	56h	58h	58h	3Ah
Character		A	D	Z	Z	;	V	X	X	:
Hexadecimal	45h	44h	56h	49h	34h	3Dh	2Bh	*1	*3	*5
Character	E	D	V	I	4	=	+	*2	*4	*6
Hexadecimal	*7	*9	03h							
Character	*8	*10								

■ Parameters (*1,*2,*3,*4,*5,*6,*7,*8,*9,*10)

	60Hz					50Hz				
Hexadecimal	30h	36h	30h	30h	30h	30h	35h	30h	30h	30h
Character	0	6	0	0	0	0	5	0	0	0
	48Hz					30Hz				
Hexadecimal	30h	34h	38h	30h	30h	30h	33h	30h	30h	30h
Character	0	4	8	0	0	0	3	0	0	0
	25Hz					24Hz				
Hexadecimal	30h	32h	35h	30h	30h	30h	32h	34h	30h	30h
Character	0	2	5	0	0	0	2	4	0	0

■ Response (Callback)

In the period when the command can be accepted

Hexadecimal	02h	56h	58h	58h	3Ah	45h	44h	56h	49h	34h
Character		V	X	X	:	E	D	V	I	4
Hexadecimal	3Dh	2Bh	*1	*3	*5	*7	*9	03h		
Character	=	+	*2	*4	*6	*8	*10			

Acceptability

SECURITY	STANDBY	ECO STANDBY	NO SIGNAL	SHUTTER	FREEZE	TEST PATTERN	REMOTE2	P IN P	LENS HOME
			✓	✓		✓	✓	✓	

3.177. SDI IN - SIGNAL LEVEL [OED]

Hexadecimal	02h	41h	44h	5Ah	5Ah	3Bh	4Fh	45h	44h	3Ah	
Character		A	D	Z	Z	;	O	E	D	:	
Hexadecimal	53h	44h	49h	2Dh	4Ch	45h	56h	45h	4Ch	*1	03h
Character	S	D	I	-	L	E	V	E	L	*2	

■ Parameters (*1,*2)

	64-940	0-1023
Hexadecimal	30h	31h
Character	0	1

■ Response (Callback)

In the period when the command can be accepted

Hexadecimal	02h	4Fh	45h	44h	3Ah	53h	44h	49h
Character		O	E	D	:	S	D	I
Hexadecimal	2Dh	4Ch	45h	56h	45h	4Ch	*1	03h
Character	-	L	E	V	E	L	*2	

Acceptability

SECURITY	STANDBY	ECO STANDBY	NO SIGNAL	SHUTTER	FREEZE	TEST PATTERN	REMOTE2	P IN P	LENS HOME
	✓		✓	✓		✓	✓	✓	

■ Note:

· Only effective for DZ780(FDZ88C), other models return ER401.

3.178. SDI IN - SDI SIGNAL LEVEL [VXX:SSL1]

Hexadecimal	02h	41h	44h	5Ah	5Ah	3Bh	56h	58h	58h	3Ah
Character		A	D	Z	Z	;	V	X	X	:
Hexadecimal	53h	53h	4Ch	49h	31h	3Dh	2Bh	*1	*3	*5
Character	S	S	L	l	1	=	+	*2	*4	*6
Hexadecimal	*7	*9	03h							
Character	*8	*10								

■ Parameters (*1,*2,*3,*4,*5,*6,*7,*8,*9,*10)

	64-940					4-1019				
Hexadecimal	30h	30h	30h	30h	30h	30h	30h	30h	30h	31h
Character	0	0	0	0	0	0	0	0	0	1

■ Response (Callback)

In the period when the command can be accepted

Hexadecimal	02h	56h	58h	58h	3Ah	53h	53h	4Ch	49h	31h
Character		V	X	X	:	S	S	L	l	1
Hexadecimal	3Dh	2Bh	*1	*3	*5	*7	*9	03h		
Character	=	+	*2	*4	*6	*8	*10			

Acceptability

SECURITY	STANDBY	ECO STANDBY	NO SIGNAL	SHUTTER	FREEZE	TEST PATTERN	REMOTE2	P IN P	LENS HOME
	✓		✓	✓		✓	✓	✓	

■ Note:

· Only effective for DZ780(FDZ88C), other models return ER401.

3.179. SDI IN - BIT DEPTH [VXX:SBT1]

Hexadecimal	02h	41h	44h	5Ah	5Ah	3Bh	56h	58h	58h	3Ah
Character		A	D	Z	Z	;	V	X	X	:
Hexadecimal	53h	42h	54h	49h	31h	3Dh	2Bh	*1	*3	*5
Character	S	B	T	l	1	=	+	*2	*4	*6
Hexadecimal	*7	*9	03h							
Character	*8	*10								

■ Parameters (*1,*2,*3,*4,*5,*6,*7,*8,*9,*10)

	AUTO					12-bit				
Hexadecimal	30h	30h	30h	30h	30h	30h	30h	30h	30h	31h
Character	0	0	0	0	0	0	0	0	0	1
	10-bit									
Hexadecimal	30h	30h	30h	30h	32h					
Character	0	0	0	0	2					

■ Response (Callback)

In the period when the command can be accepted

Hexadecimal	02h	56h	58h	58h	3Ah	53h	42h	54h	49h	31h
Character		V	X	X	:	S	B	T	l	1
Hexadecimal	3Dh	2Bh	*1	*3	*5	*7	*9	03h		
Character	=	+	*2	*4	*6	*8	*10			

Acceptability

SECURITY	STANDBY	ECO STANDBY	NO SIGNAL	SHUTTER	FREEZE	TEST PATTERN	REMOTE2	P IN P	LENS HOME
			✓	✓		✓	✓	✓	

■ Note:

· Only effective for DZ780(FDZ88C), other models return ER401.

3.180. SDI IN - 3G-SDI MAPPING [VXX:SGMI1]

Hexadecimal	02h	41h	44h	5Ah	5Ah	3Bh	56h	58h	58h	3Ah
Character		A	D	Z	Z	;	V	X	X	:
Hexadecimal	53h	47h	4Dh	49h	31h	3Dh	2Bh	*1	*3	*5
Character	S	G	M	l	1	=	+	*2	*4	*6
Hexadecimal	*7	*9	03h							
Character	*8	*10								

■ Parameters (*1,*2,*3,*4,*5,*6,*7,*8,*9,*10)

	AUTO					LEVEL A				
Hexadecimal	30h	30h	30h	30h	30h	30h	30h	30h	30h	31h
Character	0	0	0	0	0	0	0	0	0	1
	LEVEL B									
Hexadecimal	30h	30h	30h	30h	32h					
Character	0	0	0	0	2					

■ Response (Callback)

In the period when the command can be accepted

Hexadecimal	02h	56h	58h	58h	3Ah	53h	47h	4Dh	49h	31h
Character		V	X	X	:	S	G	M	l	1
Hexadecimal	3Dh	2Bh	*1	*3	*5	*7	*9	03h		
Character	=	+	*2	*4	*6	*8	*10			

Acceptability

SECURITY	STANDBY	ECO STANDBY	NO SIGNAL	SHUTTER	FREEZE	TEST PATTERN	REMOTE2	P IN P	LENS HOME
			✓	✓		✓	✓	✓	

- Note:
· Only effective for DZ780(FDZ88C), other models return ER401.

3.181. ON-SCREEN DISPLAY - OSD POSITION [ODP]

Hexadecimal	02h	41h	44h	5Ah	5Ah	3Bh	4Fh	44h	50h	3Ah
Character		A	D	Z	Z	;	O	D	P	:
Hexadecimal	*1	03h								
Character	*2									

■ Parameters (*1,*2)

	Top Left	Left Center	Bottom Left	Top Center	Center	Bottom Center
Hexadecimal	31h	32h	33h	34h	35h	36h
Character	1	2	3	4	5	6
	Top Right	Right Center	Bottom Right			
Hexadecimal	37h	38h	39h			
Character	7	8	9			

■ Response (Callback)

In the period when the command can be accepted

Hexadecimal	02h	4Fh	44h	50h	3Ah	*1	03h
Character		O	D	P	:	*2	

Acceptability

SECURITY	STANDBY	ECO STANDBY	NO SIGNAL	SHUTTER	FREEZE	TEST PATTERN	REMOTE2	P IN P	LENS HOME
	✓		✓	✓	✓	✓	✓	✓	

3.182. ON-SCREEN DISPLAY - OSD DESIGN [MOD]

Hexadecimal	02h	41h	44h	5Ah	5Ah	3Bh	4Dh	4Fh	44h	3Ah
Character		A	D	Z	Z	;	M	O	D	:
Hexadecimal	*1	03h								
Character	*2									

■ Parameters (*1,*2)

	1	2	3	4	5	6
Hexadecimal	30h	31h	32h	33h	34h	35h
Character	0	1	2	3	4	5

■ Response (Callback)

In the period when the command can be accepted

Hexadecimal	02h	4Dh	4Fh	44h	3Ah	*1	03h
Character		M	O	D	:	*2	

Acceptability

SECURITY	STANDBY	ECO STANDBY	NO SIGNAL	SHUTTER	FREEZE	TEST PATTERN	REMOTE2	P IN P	LENS HOME
	✓		✓	✓	✓	✓	✓	✓	

3.183. ON-SCREEN DISPLAY - OSD MEMORY [VXX:OMYI0]

Hexadecimal	02h	41h	44h	5Ah	5Ah	3Bh	56h	58h	58h	3Ah
Character		A	D	Z	Z	;	V	X	X	:
Hexadecimal	4Fh	4Dh	59h	49h	30h	3Dh	2Bh	*1	*3	*5
Character	O	M	Y	I	0	=	+	*2	*4	*6
Hexadecimal	*7	*9	03h							
Character	*8	*10								

■ Parameters (*1,*2,*3,*4,*5,*6,*7,*8,*9,*10)

	OFF					ON				
Hexadecimal	30h	30h	30h	30h	30h	30h	30h	30h	30h	31h
Character	0	0	0	0	0	0	0	0	0	1

■ Response (Callback)

In the period when the command can be accepted

Hexadecimal	02h	56h	58h	58h	3Ah	4Fh	4Dh	59h	49h	30h
Character		V	X	X	:	O	M	Y	I	0
Hexadecimal	3Dh	2Bh	*1	*3	*5	*7	*9	03h		
Character	=	+	*2	*4	*6	*8	*10			

Acceptability

SECURITY	STANDBY	ECO STANDBY	NO SIGNAL	SHUTTER	FREEZE	TEST PATTERN	REMOTE2	P IN P	LENS HOME
	✓		✓	✓	✓	✓	✓	✓	

3.184. ON-SCREEN DISPLAY - INPUT GUIDE [OID]

Hexadecimal	02h	41h	44h	5Ah	5Ah	3Bh	4Fh	49h	44h	3Ah
Character		A	D	Z	Z	;	O	I	D	:
Hexadecimal	*1	03h								
Character	*2									

■ Parameters (*1,*2)

	OFF	ON
Hexadecimal	30h	31h
Character	0	1

■ Response (Callback)

In the period when the command can be accepted

Hexadecimal	02h	44h	49h	44h	3Ah	*1	03h
Character		O	I	D	:	*2	

Acceptability

SECURITY	STANDBY	ECO STANDBY	NO SIGNAL	SHUTTER	FREEZE	TEST PATTERN	REMOTE2	P IN P	LENS HOME
	✓		✓	✓	✓	✓	✓	✓	

3.185. ON-SCREEN DISPLAY - WARNING MESSAGE [VXX:WMDI0]

Hexadecimal	02h	41h	44h	5Ah	5Ah	3Bh	56h	58h	58h	3Ah
Character		A	D	Z	Z	;	V	X	X	:
Hexadecimal	57h	4Dh	44h	49h	30h	3Dh	2Bh	*1	*3	*5
Character	W	M	D	I	0	=	+	*2	*4	*6
Hexadecimal	*7	*9	03h							
Character	*8	*10								

■ Parameters (*1,*2,*3,*4,*5,*6,*7,*8,*9,*10)

	OFF					ON				
Hexadecimal	30h	30h	30h	30h	30h	30h	30h	30h	30h	31h
Character	0	0	0	0	0	0	0	0	0	1

■ Response (Callback)

In the period when the command can be accepted

Hexadecimal	02h	56h	58h	58h	3Ah	57h	4Dh	44h	49h	30h
Character		V	X	X	:	W	M	D	I	0
Hexadecimal	3Dh	2Bh	*1	*3	*5	*7	*9	03h		
Character	=	+	*2	*4	*6	*8	*10			

Acceptability

SECURITY	STANDBY	ECO STANDBY	NO SIGNAL	SHUTTER	FREEZE	TEST PATTERN	REMOTE2	P IN P	LENS HOME
✓	✓		✓	✓		✓	✓	✓	

3.186. CLOSED CAPTION SETTING [OCC]

Hexadecimal	02h	41h	44h	5Ah	5Ah	3Bh	4Fh	43h	43h	3Ah
Character		A	D	Z	Z	;	O	C	C	:
Hexadecimal	*1	03h								
Character	*2									

■ Parameters (*1,*2)

	OFF	CC1	CC2	CC3	CC4
Hexadecimal	30h	31h	32h	33h	34h
Character	0	1	2	3	4

■ Response (Callback)

In the period when the command can be accepted

Hexadecimal	02h	4Fh	43h	43h	3Ah	*1	03h
Character		O	C	C	:	*2	

Acceptability

SECURITY	STANDBY	ECO STANDBY	NO SIGNAL	SHUTTER	FREEZE	TEST PATTERN	REMOTE2	P IN P	LENS HOME
							✓		

3.187. BACK COLOR [OBC]

Hexadecimal	02h	41h	44h	5Ah	5Ah	3Bh	4Fh	42h	43h	3Ah
Character		A	D	Z	Z	;	O	B	C	:
Hexadecimal	*1	03h								
Character	*2									

■ Parameters (*1,*2)

	BLUE	BLACK	USER LOGO	DEFAULT LOGO
Hexadecimal	30h	31h	32h	33h
Character	0	1	2	3

■ Response (Callback)

In the period when the command can be accepted

Hexadecimal	02h	4Fh	42h	43h	3Ah	*1	03h
Character		O	B	C	:	*2	

Acceptability

SECURITY	STANDBY	ECO STANDBY	NO SIGNAL	SHUTTER	FREEZE	TEST PATTERN	REMOTE2	P IN P	LENS HOME
	✓		✓	✓	✓	✓	✓	✓	

3.188. STARTUP LOGO [MLO]

Hexadecimal	02h	41h	44h	5Ah	5Ah	3Bh	4Dh	4Ch	4Fh	3Ah
Character		A	D	Z	Z	:	M	L	O	:
Hexadecimal	*1	03h								
Character	*2									

■ Parameters (*1,*2)

	NONE	USER LOGO	DEFAULT LOGO
Hexadecimal	30h	31h	32h
Character	0	1	2

■ Response (Callback)

In the period when the command can be accepted

Hexadecimal	02h	4Dh	4Ch	4Fh	3Ah	*1	03h
Character		M	L	O	:	*2	

Acceptability

SECURITY	STANDBY	ECO STANDBY	NO SIGNAL	SHUTTER	FREEZE	TEST PATTERN	REMOTE2	P IN P	LENS HOME
	✓		✓	✓	✓	✓	✓	✓	

3.189. UNIFORMITY - PC CORRECTION [VXX:UFMI1]

Hexadecimal	02h	41h	44h	5Ah	5Ah	3Bh	56h	58h	58h	3Ah
Character		A	D	Z	Z	:	V	X	X	:
Hexadecimal	55h	46h	4Dh	49h	31h	3Dh	2Bh	*1	*3	*5
Character	U	F	M	I	1	=	+	*2	*4	*6
Hexadecimal	*7	*9	03h							
Character	*8	*10								

■ Parameters (*1,*2,*3,*4,*5,*6,*7,*8,*9,*10)

	OFF					ON				
Hexadecimal	30h	30h	30h	30h	30h	30h	30h	30h	30h	31h
Character	0	0	0	0	0	0	0	0	0	1

■ Response (Callback)

In the period when the command can be accepted

Hexadecimal	02h	56h	58h	58h	3Ah	55h	46h	4Dh	49h	31h
Character		V	X	X	:	U	F	M	I	1
Hexadecimal	3Dh	2Bh	*1	*3	*5	*7	*9	03h		
Character	=	+	*2	*4	*6	*8	*10			

Acceptability

SECURITY	STANDBY	ECO STANDBY	NO SIGNAL	SHUTTER	FREEZE	TEST PATTERN	REMOTE2	P IN P	LENS HOME
			✓	✓		✓	✓	✓	

■ Note:

- To use this function, an optional upgrade kit (activated) is required.

3.190. SHUTTER SETTING - FADE IN [VXX:SEFS1]

Hexadecimal	02h	41h	44h	5Ah	5Ah	3Bh	56h	58h	58h	3Ah	
Character		A	D	Z	Z	:	V	X	X	:	
Hexadecimal	53h	45h	46h	53h	31h	3Dh	*1	*3	*5	*7	03h
Character	S	E	F	S	1	=	*2	*4	*6	*8	

■ Parameters (*1,*2,*3,*4,*5,*6,*7,*8,)

	OFF (0.0 s)			0.5 s			3.5 s			4.0 s		
Hexadecimal	30h	2Eh	30h	30h	2Eh	35h	33h	2Eh	35h	34h	2Eh	30h
Character	0	.	0	0	.	5	3	.	5	4	.	0
	5.0 s			7.0 s			10.0 s					
Hexadecimal	35h	2Eh	30h	37h	2Eh	30h	31h	30h	2Eh	30h		
Character	5	.	0	7	.	0	1	0	.	0		

■ Response (Callback)

In the period when the command can be accepted

Hexadecimal	02h	56h	58h	58h	3Ah	53h	45h	46h	53h	31h
Character		V	X	X	:	S	E	F	S	1
Hexadecimal	3Dh	2Bh	*1	*3	*5	*7	03h			
Character	=	+	*2	*4	*6	*8				

Acceptability

SECURITY	STANDBY	ECO STANDBY	NO SIGNAL	SHUTTER	FREEZE	TEST PATTERN	REMOTE2	P IN P	LENS HOME
✓	✓		✓	✓	✓	✓	✓	✓	✓

■ Note:

· Parameter *7 and *8 are only necessary for 10.0 settings.

3.191. SHUTTER SETTING - FADE OUT [VXX:SEFS2]

Hexadecimal	02h	41h	44h	5Ah	5Ah	3Bh	56h	58h	58h	3Ah	
Character		A	D	Z	Z	:	V	X	X	:	
Hexadecimal	53h	45h	46h	53h	32h	3Dh	*1	*3	*5	*7	03h
Character	S	E	F	S	2	=	*2	*4	*6	*8	

■ Parameters (*1,*2,*3,*4,*5,*6,*7,*8)

	OFF (0.0 s)			0.5 s			3.5 s			4.0 s		
Hexadecimal	30h	2Eh	30h	30h	2Eh	35h	33h	2Eh	35h	34h	2Eh	30h
Character	0	.	0	0	.	5	3	.	5	4	.	0
	5.0 s			7.0 s			10.0 s					
Hexadecimal	35h	2Eh	30h	37h	2Eh	30h	31h	30h	2Eh	30h		
Character	5	.	0	7	.	0	1	0	.	0		

■ Response (Callback)

In the period when the command can be accepted

Hexadecimal	02h	56h	58h	58h	3Ah	53h	45h	46h	53h	32h
Character		V	X	X	:	S	E	F	S	2
Hexadecimal	3Dh	2Bh	*1	*3	*5	*7	03h			
Character	=	+	*2	*4	*6	*8				

Acceptability

SECURITY	STANDBY	ECO STANDBY	NO SIGNAL	SHUTTER	FREEZE	TEST PATTERN	REMOTE2	P IN P	LENS HOME
✓	✓		✓	✓	✓	✓	✓	✓	✓

■ Note:

· Parameter *7 and *8 are only necessary for 10.0 settings.

3.192. SHUTTER SETTING - STARTUP [VXX:SEFI3]

Hexadecimal	02h	41h	44h	5Ah	5Ah	3Bh	56h	58h	58h	3Ah
Character		A	D	Z	Z	:	V	X	X	:
Hexadecimal	53h	45h	46h	49h	33h	3Dh	2Bh	*1	*3	*5
Character	S	E	F	l	3	=	+	*2	*4	*6
Hexadecimal	*7	*9	03h							
Character	*8	*10								

■ Parameters (*1,*2,*3,*4,*5,*6,*7,*8,*9,*10)

	OPEN					CLOSE				
Hexadecimal	30h	30h	30h	30h	30h	30h	30h	30h	30h	31h
Character	0	0	0	0	0	0	0	0	0	1

■ Response (Callback)

In the period when the command can be accepted

Hexadecimal	02h	56h	58h	58h	3Ah	53h	45h	46h	49h	33h
Character		V	X	X	:	S	E	F	l	3
Hexadecimal	3Dh	2Bh	*1	*3	*5	*7	*9	03h		
Character	=	+	*2	*4	*6	*8	*10			

Acceptability

SECURITY	STANDBY	ECO STANDBY	NO SIGNAL	SHUTTER	FREEZE	TEST PATTERN	REMOTE2	P IN P	LENS HOME
✓	✓		✓	✓	✓	✓	✓	✓	✓

3.193. SHUTTER SETTING - SHUT OFF [VXX:SEFI4]

Hexadecimal	02h	41h	44h	5Ah	5Ah	3Bh	56h	58h	58h	3Ah
Character		A	D	Z	Z	:	V	X	X	:
Hexadecimal	53h	45h	46h	49h	34h	3Dh	2Bh	*1	*3	*5
Character	S	E	F	l	4	=	+	*2	*4	*6
Hexadecimal	*7	*9	03h							
Character	*8	*10								

■ Parameters (*1,*2,*3,*4,*5,*6,*7,*8,*9,*10)

	OPEN					CLOSE				
Hexadecimal	30h	30h	30h	30h	30h	30h	30h	30h	30h	31h
Character	0	0	0	0	0	0	0	0	0	1
	KEEP CURRENT STATE									
Hexadecimal	30h	30h	30h	30h	32h					
Character	0	0	0	0	2					

■ Response (Callback)

In the period when the command can be accepted

Hexadecimal	02h	56h	58h	58h	3Ah	53h	45h	46h	49h	34h
Character		V	X	X	:	S	E	F	I	4
Hexadecimal	3Dh	2Bh	*1	*3	*5	*7	*9	03h		
Character	=	+	*2	*4	*6	*8	*10			

Acceptability

SECURITY	STANDBY	ECO STANDBY	NO SIGNAL	SHUTTER	FREEZE	TEST PATTERN	REMOTE2	P IN P	LENS HOME
✓	✓		✓	✓	✓	✓	✓	✓	✓

3.194. WAVEFORM MONITOR [OWM]

Hexadecimal	02h	41h	44h	5Ah	5Ah	3Bh	4Fh	57h	4Dh	3Ah
Character		A	D	Z	Z	:	O	W	M	:
Hexadecimal	*1	03h								
Character	*2									

■ Parameters (*1,*2)

	OFF	Luminance-line	Red-line	Green-line	Blue-line
Hexadecimal	30h	35h	36h	37h	38h
Character	0	5	6	7	8

■ Response (Callback)

In the period when the command can be accepted

Hexadecimal	02h	4Fh	57h	4Dh	3Ah	*1	03h
Character		O	W	M	:	*2	

Acceptability

SECURITY	STANDBY	ECO STANDBY	NO SIGNAL	SHUTTER	FREEZE	TEST PATTERN	REMOTE2	P IN P	LENS HOME
			✓	✓	✓	✓	✓		

3.195. WAVEFORM MONITOR - ADJUST [VXX:WMLI0]

Hexadecimal	02h	41h	44h	5Ah	5Ah	3Bh	56h	58h	58h	3Ah	57h	4Dh
Character		A	D	Z	Z	:	V	X	X	:	W	M
Hexadecimal	4Ch	49h	30h	3Dh	2Bh	*1	*3	*5	*7	*9	03h	
Character	L	I	0	=	+	*2	*4	*6	*8	*10		

■ Parameters (*1,*2,*3,*4,*5,*6,*7,*8,*9,*10)

	0					1				
Hexadecimal	30h	30h	30h	30h	30h	30h	30h	30h	30h	31h
Character	0	0	0	0	0	0	0	0	0	1
	1198					1199				
Hexadecimal	30h	31h	31h	39h	38h	30h	31h	31h	39h	39h
Character	0	1	1	9	8	0	1	1	9	9

■ Response (Callback)

In the period when the command can be accepted

Hexadecimal	02h	56h	58h	58h	3Ah	57h	4Dh	4Ch	49h	30h
Character		V	X	X	:	W	M	L	I	0
Hexadecimal	3Dh	2Bh	*1	*3	*5	*7	*9	03h		
Character	=	+	*2	*4	*6	*8	*10			

Acceptability

SECURITY	STANDBY	ECO STANDBY	NO SIGNAL	SHUTTER	FREEZE	TEST PATTERN	REMOTE2	P IN P	LENS HOME
			✓	✓	✓	✓	✓		

3.196. CUT OFF - RED [VXX:CUT11]

Hexadecimal	02h	41h	44h	5Ah	5Ah	3Bh	56h	58h	58h	3Ah
Character		A	D	Z	Z	:	V	X	X	:
Hexadecimal	43h	55h	54h	49h	31h	3Dh	2Bh	*1	*3	*5
Character	C	U	T	I	1	=	+	*2	*4	*6
Hexadecimal	*7	*9	03h							
Character	*8	*10								

■ Parameters (*1,*2,*3,*4,*5,*6,*7,*8,*9,*10)

	OFF					ON				
Hexadecimal	30h	30h	30h	30h	30h	30h	30h	30h	30h	31h
Character	0	0	0	0	0	0	0	0	0	1

■ Response (Callback)

In the period when the command can be accepted

Hexadecimal	02h	56h	58h	58h	3Ah	43h	55h	54h	49h	31h
Character		V	X	X	:	C	U	T	I	1
Hexadecimal	3Dh	2Bh	*1	*3	*5	*7	*9	03h		
Character	=	+	*2	*4	*6	*8	*10			

Acceptability

SECURITY	STANDBY	ECO STANDBY	NO SIGNAL	SHUTTER	FREEZE	TEST PATTERN	REMOTE2	P IN P	LENS HOME
✓			✓	✓	✓	✓	✓	✓	✓

3.197. CUT OFF - GREEN [VXX:CUT12]

Hexadecimal	02h	41h	44h	5Ah	5Ah	3Bh	56h	58h	58h	3Ah
Character		A	D	Z	Z	;	V	X	X	:
Hexadecimal	43h	55h	54h	49h	32h	3Dh	2Bh	*1	*3	*5
Character	C	U	T	l	2	=	+	*2	*4	*6
Hexadecimal	*7	*9	03h							
Character	*8	*10								

■ Parameters (*1,*2,*3,*4,*5,*6,*7,*8,*9,*10)

	OFF					ON				
Hexadecimal	30h	30h	30h	30h	30h	30h	30h	30h	30h	31h
Character	0	0	0	0	0	0	0	0	0	1

■ Response (Callback)

In the period when the command can be accepted

Hexadecimal	02h	56h	58h	58h	3Ah	43h	55h	54h	49h	32h
Character		V	X	X	:	C	U	T	l	2
Hexadecimal	3Dh	2Bh	*1	*3	*5	*7	*9	03h		
Character	=	+	*2	*4	*6	*8	*10			

Acceptability

SECURITY	STANDBY	ECO STANDBY	NO SIGNAL	SHUTTER	FREEZE	TEST PATTERN	REMOTE2	P IN P	LENS HOME
✓			✓	✓	✓	✓	✓	✓	✓

3.198. CUT OFF - BLUE [VXX:CUT13]

Hexadecimal	02h	41h	44h	5Ah	5Ah	3Bh	56h	58h	58h	3Ah
Character		A	D	Z	Z	;	V	X	X	:
Hexadecimal	43h	55h	54h	49h	33h	3Dh	2Bh	*1	*3	*5
Character	C	U	T	l	3	=	+	*2	*4	*6
Hexadecimal	*7	*9	03h							
Character	*8	*10								

■ Parameters (*1,*2,*3,*4,*5,*6,*7,*8,*9,*10)

	OFF					ON				
Hexadecimal	30h	30h	30h	30h	30h	30h	30h	30h	30h	31h
Character	0	0	0	0	0	0	0	0	0	1

■ Response (Callback)

In the period when the command can be accepted

Hexadecimal	02h	56h	58h	58h	3Ah	43h	55h	54h	49h	33h
Character		V	X	X	:	C	U	T	l	3
Hexadecimal	3Dh	2Bh	*1	*3	*5	*7	*9	03h		
Character	=	+	*2	*4	*6	*8	*10			

Acceptability

SECURITY	STANDBY	ECO STANDBY	NO SIGNAL	SHUTTER	FREEZE	TEST PATTERN	REMOTE2	P IN P	LENS HOME
✓			✓	✓	✓	✓	✓	✓	✓

3.199. P IN P [OPP]

Hexadecimal	02h	41h	44h	5Ah	5Ah	3Bh	4Fh	50h	50h	3Ah
Character		A	D	Z	Z	;	O	P	P	:
Hexadecimal	*1	03h								
Character	*2									

■ Parameters (*1,*2)

	OFF	USER1	USER2	USER3
Hexadecimal	30h	31h	32h	33h
Character	0	1	2	3

■ Response (Callback)

In the period when the command can be accepted

Hexadecimal	02h	4Fh	50h	50h	3Ah	*1	03h
Character		O	P	P	:	*2	

Acceptability

SECURITY	STANDBY	ECO STANDBY	NO SIGNAL	SHUTTER	FREEZE	TEST PATTERN	REMOTE2	P IN P	LENS HOME
	✓		✓	✓		✓	✓	✓	

3.200. P IN P - MAIN WINDOW [MSI]

Hexadecimal	02h	41h	44h	5Ah	5Ah	3Bh	4Dh	53h	49h	3Ah
Character		A	D	Z	Z	;	M	S	I	:
Hexadecimal	*1	*3	*5	03h						
Character	*2	*4	*6							

■ Parameters (*1, *2, *3, *4, *5, *6)

	RGB1			RGB2					
Hexadecimal	52h	47h	31h	52h	47h	32h			
Character	R	G	1	R	G	2			
	DVI			HDMI			SDI		
Hexadecimal	44h	56h	49h	48h	44h	31h	53h	44h	31h
Character	D	V	I	H	D	1	S	D	1

■ Response (Callback)

In the period when the command can be accepted

Hexadecimal	02h	4Dh	53h	49h	3Ah	*1	*3	*5	03h
Character		M	S	I	:	*2	*4	*6	

Acceptability

SECURITY	STANDBY	ECO STANDBY	NO SIGNAL	SHUTTER	FREEZE	TEST PATTERN	REMOTE2	P IN P	LENS HOME
			✓	✓		✓	✓	✓	

■ Note:

- Parameter [SDI] is only DZ780(FDZ88C).
- If the combination with the SUB WINDOW is not possible, return ER402.

3.201. P IN P - MAIN WINDOW SIZE - INTERLOCKED [MSL]

Hexadecimal	02h	41h	44h	5Ah	5Ah	3Bh	4Dh	53h	4Ch	3Ah
Character		A	D	Z	Z	;	M	S	L	:
Hexadecimal	*1	03h								
Character	*2									

■ Parameters (*1, *2)

	OFF	ON
Hexadecimal	30h	31h
Character	0	1

■ Response (Callback)

In the period when the command can be accepted

Hexadecimal	02h	4Dh	53h	4Ch	3Ah	*1	03h
Character		M	S	L	:	*2	

Acceptability

SECURITY	STANDBY	ECO STANDBY	NO SIGNAL	SHUTTER	FREEZE	TEST PATTERN	REMOTE2	P IN P	LENS HOME
			✓	✓		✓	✓	✓	

3.202. P IN P - MAIN WINDOW SIZE - VERTICAL [MSV]

Hexadecimal	02h	41h	44h	5Ah	5Ah	3Bh	4Dh	53h	56h	3Ah
Character		A	D	Z	Z	;	M	S	V	:
Hexadecimal	*1	*3	*5	03h						
Character	*2	*4	*6							

■ Parameters (*1, *2, *3, *4, *5, *6)

	10		11		12		13		
Hexadecimal	31h	30h	31h	31h	31h	32h	31h	33h	
Character	1	0	1	1	1	2	1	3	
	97		98		99		100		
Hexadecimal	39h	37h	39h	38h	39h	39h	31h	30h	30h
Character	9	7	9	8	9	9	1	0	0

■ Response (Callback)

In the period when the command can be accepted

Hexadecimal	02h	4Dh	53h	56h	3Ah	*1	*3	*5	03h
Character		M	S	V	:	*2	*4	*6	

Acceptability

SECURITY	STANDBY	ECO STANDBY	NO SIGNAL	SHUTTER	FREEZE	TEST PATTERN	REMOTE2	P IN P	LENS HOME
			✓	✓		✓	✓	✓	

3.203. P IN P - MAIN WINDOW SIZE - HORIZONTAL [MSH]

Hexadecimal	02h	41h	44h	5Ah	5Ah	3Bh	4Dh	53h	48h	3Ah
Character		A	D	Z	Z	;	M	S	H	:
Hexadecimal	*1	*3	*5	03h						
Character	*2	*4	*6							

■ Parameters (*1, *2, *3, *4, *5, *6)

	10		11		12		13		
Hexadecimal	31h	30h	31h	31h	31h	32h	31h	33h	
Character	1	0	1	1	1	2	1	3	
	97		98		99		100		
Hexadecimal	39h	37h	39h	38h	39h	39h	31h	30h	30h
Character	9	7	9	8	9	9	1	0	0

■ Response (Callback)

In the period when the command can be accepted

Hexadecimal	02h	4Dh	53h	48h	3Ah	*1	*3	*5	03h
Character		M	S	H	:	*2	*4	*6	

Acceptability

SECURITY	STANDBY	ECO STANDBY	NO SIGNAL	SHUTTER	FREEZE	TEST PATTERN	REMOTE2	P IN P	LENS HOME
			✓	✓		✓	✓	✓	

3.204. P IN P - MAIN WINDOW SIZE - BOTH [MSZ]

Hexadecimal	02h	41h	44h	5Ah	5Ah	3Bh	4Dh	53h	5Ah	3Ah
Character		A	D	Z	Z	;	M	S	Z	:
Hexadecimal	*1	*3	*5	03h						
Character	*2	*4	*6							

■ Parameters (*1, *2, *3, *4, *5, *6)

	10		11		12		13		
Hexadecimal	31h	30h	31h	31h	31h	32h	31h	33h	
Character	1	0	1	1	1	2	1	3	
	97		98		99		100		
Hexadecimal	39h	37h	39h	38h	39h	39h	31h	30h	30h
Character	9	7	9	8	9	9	1	0	0

■ Response (Callback)

In the period when the command can be accepted

Hexadecimal	02h	4Dh	53h	5Ah	3Ah	*1	*3	*5	03h
Character		M	S	Z	:	*2	*4	*6	

Acceptability

SECURITY	STANDBY	ECO STANDBY	NO SIGNAL	SHUTTER	FREEZE	TEST PATTERN	REMOTE2	P IN P	LENS HOME
			✓	✓		✓	✓	✓	

3.205. P IN P - MAIN WINDOW POSITION - VERTICAL [MPV]

Hexadecimal	02h	41h	44h	5Ah	5Ah	3Bh	4Dh	50h	56h	3Ah
Character		A	D	Z	Z	;	M	P	V	:
Hexadecimal	*1	*3	*5	*7	03h					
Character	*2	*4	*6	*8						

■ Parameters (*1, *2, *3, *4, *5, *6, *7, *8)

	-364				-363				-362			
Hexadecimal	2Dh	33h	36h	34h	2Dh	33h	36h	33h	2Dh	33h	36h	32h
Character	-	3	6	4	-	3	6	3	-	3	6	2
	+362				+363				+364			
Hexadecimal	2Bh	33h	36h	32h	2Bh	33h	36h	33h	2Bh	33h	36h	34h
Character	+	3	6	2	+	3	6	3	+	3	6	4

■ Response (Callback)

In the period when the command can be accepted

Hexadecimal	02h	4Dh	50h	56h	3Ah	*1	*3	*5	*7	03h
Character		M	P	V	:	*2	*4	*6	*8	

Acceptability

SECURITY	STANDBY	ECO STANDBY	NO SIGNAL	SHUTTER	FREEZE	TEST PATTERN	REMOTE2	P IN P	LENS HOME
			✓	✓		✓	✓	✓	

■ Note:

· Maximum value and minimum value are different depending by model or input signal, menu setting conditions.

3.206. P IN P - MAIN WINDOW POSITION - HORIZONTAL [MPH]

Hexadecimal	02h	41h	44h	5Ah	5Ah	3Bh	4Dh	50h	48h	3Ah
Character		A	D	Z	Z	;	M	P	H	:
Hexadecimal	*1	*3	*5	*7	03h					
Character	*2	*4	*6	*8						

■ Parameters (*1, *2, *3, *4, *5, *6, *7, *8)

	-651				-650				-649			
Hexadecimal	2Dh	36h	35h	31h	2Dh	36h	35h	30h	2Dh	36h	34h	39h
Character	-	6	5	1	-	6	5	0	-	6	4	9
	+649				+650				+651			
Hexadecimal	2Bh	36h	34h	39h	2Bh	36h	35h	30h	2Bh	36h	35h	31h
Character	+	6	4	9	+	6	5	0	+	6	5	1

■ Response (Callback)

In the period when the command can be accepted

Hexadecimal	02h	4Dh	50h	48h	3Ah	*1	*3	*5	*7	03h
Character		M	P	H	:	*2	*4	*6	*8	

Acceptability

SECURITY	STANDBY	ECO STANDBY	NO SIGNAL	SHUTTER	FREEZE	TEST PATTERN	REMOTE2	P IN P	LENS HOME
			✓	✓		✓	✓	✓	

■ Note:

· Maximum value and minimum value are different depending by model or input signal, menu setting conditions.

3.207. P IN P - SUB WINDOW [SIS]

Hexadecimal	02h	41h	44h	5Ah	5Ah	3Bh	53h	49h	53h	3Ah
Character		A	D	Z	Z	;	S	I	S	:
Hexadecimal	*1	*3	*5	03h						
Character	*2	*4	*6							

■ Parameters (*1, *2, *3, *4, *5, *6)

	RGB1			RGB2			DIGITAL LINK		
Hexadecimal	52h	47h	44h	4Ch	31h	32h	44h	4Ch	31h
Character	R	G	D	L	1	2	D	L	1
	DVI			HDMI			SDI		
Hexadecimal	44h	56h	49h	48h	44h	31h	53h	44h	31h
Character	D	V	I	H	D	1	S	D	1

■ Response (Callback)

In the period when the command can be accepted

Hexadecimal	02h	53h	49h	53h	3Ah	*1	*3	*5	03h
Character		S	I	S	:	*2	*4	*6	

Acceptability

SECURITY	STANDBY	ECO STANDBY	NO SIGNAL	SHUTTER	FREEZE	TEST PATTERN	REMOTE2	P IN P	LENS HOME
			✓	✓		✓	✓	✓	

■ Note:

· Parameter [SDI] is only DZ780(FDZ88C).
· If the combination with the MAIN WINDOW is not possible, return ER402.

3.208. P IN P - SUB WINDOW SIZE - INTERLOCKED [SSL]

Hexadecimal	02h	41h	44h	5Ah	5Ah	3Bh	53h	53h	4Ch	3Ah
Character		A	D	Z	Z	;	S	S	L	:
Hexadecimal	*1	03h								
Character	*2									

■ Parameters (*1, *2)

	OFF	ON
Hexadecimal	30h	31h
Character	0	1

■ Response (Callback)

In the period when the command can be accepted

Hexadecimal	02h	53h	53h	4Ch	3Ah	*1	03h
Character		S	S	L	:	*2	

Acceptability

SECURITY	STANDBY	ECO STANDBY	NO SIGNAL	SHUTTER	FREEZE	TEST PATTERN	REMOTE2	P IN P	LENS HOME
			✓	✓		✓	✓	✓	

3.209. P IN P - SUB WINDOW SIZE - VERTICAL [SSV]

Hexadecimal	02h	41h	44h	5Ah	5Ah	3Bh	53h	53h	56h	3Ah
Character		A	D	Z	Z	;	S	S	V	:
Hexadecimal	*1	*3	*5	03h						
Character	*2	*4	*6							

■ Parameters (*1,*2,*3,*4,*5,*6)

	10		11		12		13		
Hexadecimal	31h	30h	31h	31h	31h	32h	31h	33h	
Character	1	0	1	1	1	2	1	3	
	97		98		99		100		
Hexadecimal	39h	37h	39h	38h	39h	39h	31h	30h	30h
Character	9	7	9	8	9	9	1	0	0

■ Response (Callback)

In the period when the command can be accepted

Hexadecimal	02h	53h	53h	56h	3Ah	*1	*3	*5	03h
Character		S	S	V	:	*2	*4	*6	

Acceptability

SECURITY	STANDBY	ECO STANDBY	NO SIGNAL	SHUTTER	FREEZE	TEST PATTERN	REMOTE2	P IN P	LENS HOME
			✓	✓		✓	✓	✓	

3.210. P IN P - SUB WINDOW SIZE - HORIZONTAL [SSH]

Hexadecimal	02h	41h	44h	5Ah	5Ah	3Bh	53h	53h	48h	3Ah
Character		A	D	Z	Z	;	S	S	H	:
Hexadecimal	*1	*3	*5	03h						
Character	*2	*4	*6							

■ Parameters (*1,*2,*3,*4,*5,*6)

	10		11		12		13		
Hexadecimal	31h	30h	31h	31h	31h	32h	31h	33h	
Character	1	0	1	1	1	2	1	3	
	97		98		99		100		
Hexadecimal	39h	37h	39h	38h	39h	39h	31h	30h	30h
Character	9	7	9	8	9	9	1	0	0

■ Response (Callback)

In the period when the command can be accepted

Hexadecimal	02h	53h	53h	48h	3Ah	*1	*3	*5	03h
Character		S	S	H	:	*2	*4	*6	

Acceptability

SECURITY	STANDBY	ECO STANDBY	NO SIGNAL	SHUTTER	FREEZE	TEST PATTERN	REMOTE2	P IN P	LENS HOME
			✓	✓		✓	✓	✓	

3.211. P IN P - SUB WINDOW SIZE - BOTH [SSZ]

Hexadecimal	02h	41h	44h	5Ah	5Ah	3Bh	53h	53h	5Ah	3Ah
Character		A	D	Z	Z	;	S	S	Z	:
Hexadecimal	*1	*3	*5	03h						
Character	*2	*4	*6							

■ Parameters (*1,*2,*3,*4,*5,*6)

	10		11		12		13		
Hexadecimal	31h	30h	31h	31h	31h	32h	31h	33h	
Character	1	0	1	1	1	2	1	3	
	97		98		99		100		
Hexadecimal	39h	37h	39h	38h	39h	39h	31h	30h	30h
Character	9	7	9	8	9	9	1	0	0

■ Response (Callback)

In the period when the command can be accepted

Hexadecimal	02h	53h	53h	5Ah	3Ah	*1	*3	*5	03h
Character		S	S	Z	:	*2	*4	*6	

Acceptability

SECURITY	STANDBY	ECO STANDBY	NO SIGNAL	SHUTTER	FREEZE	TEST PATTERN	REMOTE2	P IN P	LENS HOME
			✓	✓		✓	✓	✓	

3.212. P IN P - SUB WINDOW POSITION - VERTICAL [SPV]

Hexadecimal	02h	41h	44h	5Ah	5Ah	3Bh	53h	50h	56h	3Ah
Character		A	D	Z	Z	;	S	P	V	:
Hexadecimal	*1	*3	*5	*7	03h					
Character	*2	*4	*6	*8						

■ Parameters (*1,*2,*3,*4,*5,*6,*7,*8)

	-364				-363				-362			
Hexadecimal	2Dh	33h	36h	34h	2Dh	33h	36h	33h	2Dh	33h	36h	32h
Character	-	3	6	4	-	3	6	3	-	3	6	2
	+362				+363				+364			
Hexadecimal	2Bh	33h	36h	32h	2Bh	33h	36h	33h	2Bh	33h	36h	34h
Character	+	3	6	2	+	3	6	3	+	3	6	4

■ Response (Callback)

In the period when the command can be accepted

Hexadecimal	02h	53h	50h	56h	3Ah	*1	*3	*5	*7	03h
Character		S	P	V	:	*2	*4	*6	*8	

Acceptability

SECURITY	STANDBY	ECO STANDBY	NO SIGNAL	SHUTTER	FREEZE	TEST PATTERN	REMOTE2	P IN P	LENS HOME
			✓	✓		✓	✓	✓	

■ Note:

· Maximum value and minimum value are different depending by model or input signal, menu setting conditions.

3.213. P IN P - SUB WINDOW POSITION - HORIZONTAL [SPH]

Hexadecimal	02h	41h	44h	5Ah	5Ah	3Bh	53h	50h	48h	3Ah
Character		A	D	Z	Z	;	S	P	H	:
Hexadecimal	*1	*3	*5	*7	03h					
Character	*2	*4	*6	*8						

■ Parameters (*1,*2,*3,*4,*5,*6,*7,*8)

	-651				-650				-649			
Hexadecimal	2Dh	36h	35h	31h	2Dh	36h	35h	30h	2Dh	36h	34h	39h
Character	-	6	5	1	-	6	5	0	-	6	4	9
	+649				+650				+651			
Hexadecimal	2Bh	36h	34h	39h	2Bh	36h	35h	30h	2Bh	36h	35h	31h
Character	+	6	4	9	+	6	5	0	+	6	5	1

■ Response (Callback)

In the period when the command can be accepted

Hexadecimal	02h	53h	50h	48h	3Ah	*1	*3	*5	*7	03h
Character		S	P	H	:	*2	*4	*6	*8	

Acceptability

SECURITY	STANDBY	ECO STANDBY	NO SIGNAL	SHUTTER	FREEZE	TEST PATTERN	REMOTE2	P IN P	LENS HOME
			✓	✓		✓	✓	✓	

■ Note:

· Maximum value and minimum value are different depending by model or input signal, menu setting conditions.

3.214. P IN P - SUB WINDOW - CLOCK PHASE [VXX:SCPI0]

Hexadecimal	02h	41h	44h	5Ah	5Ah	3Bh	56h	58h	58h	3Ah	
Character		A	D	Z	Z	;	V	X	X	:	
Hexadecimal	53h	43h	50h	49h	30h	3Dh	2Bh	*1	*3	*5	
Character	S	C	P	I	0	=	+	*2	*4	*6	
Hexadecimal	*7	*9	03h								
Character	*8	*10									

■ Parameters (*1,*2,*3,*4,*5,*6,*7,*8,*9,*10)

	0					1				
Hexadecimal	30h	30h	30h	30h	30h	30h	30h	30h	30h	31h
Character	0	0	0	0	0	0	0	0	0	1
	30					31				
Hexadecimal	30h	30h	30h	30h	30h	30h	30h	30h	33h	31h
Character	0	0	0	3	0	0	0	0	3	1

■ Response (Callback)

In the period when the command can be accepted

Hexadecimal	02h	56h	58h	58h	3Ah	53h	43h	50h	49h	30h
Character		V	X	X	:	S	C	P	I	0
Hexadecimal	3Dh	2Bh	*1	*3	*5	*7	*9	03h		
Character	=	+	*2	*4	*6	*8	*10			

Acceptability

SECURITY	STANDBY	ECO STANDBY	NO SIGNAL	SHUTTER	FREEZE	TEST PATTERN	REMOTE2	P IN P	LENS HOME
			✓	✓		✓	✓	✓	

- Note:
 - ER401 is returned when there is no input signal of a SUB WINDOW.
 - SUB CLOCK PHASE of the 3D SETTINGS can also be set.

3.215. P IN P - FRAME LOCK [PFL]

Hexadecimal	02h	41h	44h	5Ah	5Ah	3Bh	50h	46h	4Ch	3Ah
Character		A	D	Z	Z	;	P	F	L	:
Hexadecimal	*1	03h								
Character	*2									

■ Parameters (*1,*2)

	Main Window	Sub Window
Hexadecimal	30h	31h
Character	0	1

■ Response (Callback)

In the period when the command can be accepted

Hexadecimal	02h	50h	46h	4Ch	3Ah	*1	03h
Character		P	F	L	:	*2	

Acceptability

SECURITY	STANDBY	ECO STANDBY	NO SIGNAL	SHUTTER	FREEZE	TEST PATTERN	REMOTE2	P IN P	LENS HOME
			✓	✓		✓	✓	✓	

3.216. P IN P - TYPE [PTP]

Hexadecimal	02h	41h	44h	5Ah	5Ah	3Bh	50h	54h	50h	3Ah
Character		A	D	Z	Z	;	P	T	P	:
Hexadecimal	*1	03h								
Character	*2									

■ Parameters (*1,*2)

	Main Window	Sub Window
Hexadecimal	30h	31h
Character	0	1

■ Response (Callback)

In the period when the command can be accepted

Hexadecimal	02h	50h	54h	50h	3Ah	*1	03h
Character		P	T	P	:	*2	

Acceptability

SECURITY	STANDBY	ECO STANDBY	NO SIGNAL	SHUTTER	FREEZE	TEST PATTERN	REMOTE2	P IN P	LENS HOME
			✓	✓		✓	✓	✓	

3.217. PROJECTOR ID [RIS]

Hexadecimal	02h	41h	44h	5Ah	5Ah	3Bh	52h	49h	53h	3Ah
Character		A	D	Z	Z	;	R	I	S	:
Hexadecimal	*1	*3	03h							
Character	*2	*4								

Parameters (*1,*2,*3,*4)

	ALL	1	2	62	63	64						
Hexadecimal	30h	30h	30h	31h	30h	32h	36h	32h	36h	33h	36h	34h
Character	0	0	0	1	0	2	6	2	6	3	6	4

■ Response (Callback)

In the period when the command can be accepted

Hexadecimal	02h	52h	49h	53h	3Ah	*1	*3	03h
Character		R	I	S	:	*2	*4	

Acceptability

SECURITY	STANDBY	ECO STANDBY	NO SIGNAL	SHUTTER	FREEZE	TEST PATTERN	REMOTE2	P IN P	LENS HOME
	✓		✓	✓		✓	✓	✓	

3.218. PROJECTION METHOD [OIL]

Hexadecimal	02h	41h	44h	5Ah	5Ah	3Bh	4Fh	49h	4Ch	3Ah	*1	03h
Character		A	D	Z	Z	;	O	I	L	:	*2	

■ Parameters (*1,*2)

	FRONT/FLOOR	REAR/FLOOR	FRONT/CEILING	REAR/CEILING
Hexadecimal	30h	31h	32h	33h
Character	0	1	2	3

■ Response (Callback)

In the period when the command can be accepted

Hexadecimal	02h	4Fh	49h	4Ch	3Ah	*1	03h
Character		O	I	L	:	*2	

Acceptability

SECURITY	STANDBY	ECO STANDBY	NO SIGNAL	SHUTTER	FREEZE	TEST PATTERN	REMOTE2	P IN P	LENS HOME
	✓		✓	✓		✓	✓	✓	

3.219. COOLING CONDITION [ODR]

Hexadecimal	02h	41h	44h	5Ah	5Ah	3Bh	4Fh	44h	52h	3Ah	*1	03h
Character		A	D	Z	Z	;	O	D	R	:	*2	

■ Parameters (*1,*2)

	FLOOR	CEILING	VERTICAL UP	VERTICAL DOWN	AUTO
Hexadecimal	30h	31h	32h	33h	39h
Character	0	1	2	3	9

■ Response (Callback)

In the period when the command can be accepted

Hexadecimal	02h	4Fh	44h	52h	3Ah	*1	03h
Character		O	D	R	:	*2	

Acceptability

SECURITY	STANDBY	ECO STANDBY	NO SIGNAL	SHUTTER	FREEZE	TEST PATTERN	REMOTE2	P IN P	LENS HOME
	✓		✓	✓		✓	✓	✓	

■ Note:

· When using a lamp for portrait mode, ER401 is returned.

3.220. HIGH ALTITUDE MODE [OFM]

Hexadecimal	02h	41h	44h	5Ah	5Ah	3Bh	4Fh	46h	4Dh	3Ah	*1	03h
Character		A	D	Z	Z	;	O	F	M	:	*2	

Parameters (*1,*2)

	OFF	ON
Hexadecimal	30h	31h
Character	0	1

■ Response (Callback)

In the period when the command can be accepted

Hexadecimal	02h	4Fh	46h	4Dh	3Ah	*1	03h
Character		O	F	M	:	*2	

Acceptability

SECURITY	STANDBY	ECO STANDBY	NO SIGNAL	SHUTTER	FREEZE	TEST PATTERN	REMOTE2	P IN P	LENS HOME
	✓	✓	✓	✓		✓	✓	✓	

3.221. LAMP SELECT [LPM]

Hexadecimal	02h	41h	44h	5Ah	5Ah	3Bh	4Ch	50h	4Dh	3Ah	*1	03h
Character		A	D	Z	Z	;	L	P	M	:	*2	

■ Parameters (*1,*2,*3,*4)

	DUAL	Single	LAMP 1	LAMP 2
Hexadecimal	30h	31h	32h	33h
Character	0	1	2	3

■ Response (Callback)

In the period when the command can be accepted

Hexadecimal	02h	4Ch	50h	4Dh	3Ah	*1	*3	03h
Character		L	P	M	:	*2	*4	

Acceptability

SECURITY	STANDBY	ECO STANDBY	NO SIGNAL	SHUTTER	FREEZE	TEST PATTERN	REMOTE2	P IN P	LENS HOME
	✓		✓	✓		✓	✓	✓	

■ Note:

· ER401 is returned during lamp select operation.
· [SINGLE] is short usage time lamps will automatically selected.

3.222. LAMP RELAY [VXX:LRY10]

Hexadecimal	02h	41h	44h	5Ah	5Ah	3Bh	56h	58h	58h	3Ah
Character		A	D	Z	Z	;	V	X	X	:
Hexadecimal	4Ch	52h	59h	49h	30h	3Dh	2Bh	*1	*3	*5
Character	L	R	Y	I	0	=	+	*2	*4	*6
Hexadecimal	*7	*9	03h							
Character	*8	*10								

■ Parameters (*1,*2,*3,*4,*5,*6,*7,*8,*9,*10)

	OFF					00:01					00:02				
Hexadecimal	30h	30h	30h	30h	30h	30h	30h	30h	30h	31h	30h	30h	30h	30h	32h
Character	0	0	0	0	0	0	0	0	0	1	0	0	0	0	2
	23:58					23:59					00:00				
Hexadecimal	30h	32h	33h	35h	38h	30h	32h	33h	35h	39h	30h	32h	34h	30h	30h
Character	0	2	3	5	8	0	2	3	5	9	0	2	4	0	0

■ Response (Callback)

In the period when the command can be accepted

Hexadecimal	02h	56h	58h	58h	3Ah	4Ch	52h	59h	49h	30h
Character		V	X	X	:	L	R	Y	I	0
Hexadecimal	3Dh	2Bh	*1	*3	*5	*7	*9	03h		
Character	=	+	*2	*4	*6	*8	*10			

Acceptability

SECURITY	STANDBY	ECO STANDBY	NO SIGNAL	SHUTTER	FREEZE	TEST PATTERN	REMOTE2	P IN P	LENS HOME
	✓		✓	✓		✓	✓	✓	

3.223. LAMP RELAY WEEK [VXX:LRYI2]

Hexadecimal	02h	41h	44h	5Ah	5Ah	3Bh	56h	58h	58h	3Ah
Character		A	D	Z	Z	;	V	X	X	:
Hexadecimal	4Ch	52h	59h	49h	32h	3Dh	2Bh	*1	*3	*5
Character	L	R	Y	I	2	=	+	*2	*4	*6
Hexadecimal	*7	*9	03h							
Character	*8	*10								

■ Parameters (*1,*2,*3,*4,*5,*6,*7,*8,*9,*10)

	OFF					EVERY DAY					SUN				
Hexadecimal	30h	30h	30h	30h	30h	30h	30h	30h	30h	31h	30h	30h	30h	30h	32h
Character	0	0	0	0	0	0	0	0	0	1	0	0	0	0	2
	MON					TUE					WED				
Hexadecimal	30h	30h	30h	30h	33h	30h	30h	30h	30h	34h	30h	30h	30h	30h	35h
Character	0	0	0	0	3	0	0	0	0	4	0	0	0	0	5
	THU					FRI					SAT				
Hexadecimal	30h	30h	30h	30h	36h	30h	30h	30h	30h	37h	30h	30h	30h	30h	38h
Character	0	0	0	0	6	0	0	0	0	7	0	0	0	0	8

■ Response (Callback)

In the period when the command can be accepted

Hexadecimal	02h	56h	58h	58h	3Ah	4Ch	52h	59h	49h	32h
Character		V	X	X	:	L	R	Y	I	2
Hexadecimal	3Dh	2Bh	*1	*3	*5	*7	*9	03h		
Character	=	+	*2	*4	*6	*8	*10			

Acceptability

SECURITY	STANDBY	ECO STANDBY	NO SIGNAL	SHUTTER	FREEZE	TEST PATTERN	REMOTE2	P IN P	LENS HOME
	✓		✓	✓		✓	✓	✓	

3.224. LAMP POWER [VXX:LPWI1]

Hexadecimal	02h	41h	44h	5Ah	5Ah	3Bh	56h	58h	58h	3Ah
Character		A	D	Z	Z	;	V	X	X	:
Hexadecimal	4Ch	50h	57h	49h	31h	3Dh	2Bh	*1	*3	*5
Character	L	P	W	I	1	=	+	*2	*4	*6
Hexadecimal	*7	*9	03h							
Character	*8	*10								

■ Parameters (*1,*2,*3,*4,*5,*6,*7,*8,*9,*10)

	ECO					Normal				
Hexadecimal	30h	30h	30h	30h	30h	30h	30h	30h	30h	31h
Character	0	0	0	0	0	0	0	0	0	1

■ Response (Callback)

In the period when the command can be accepted

Hexadecimal	02h	56h	58h	58h	3Ah	4Ch	50h	57h	49h	31h
Character		V	X	X	:	L	P	W	I	1
Hexadecimal	3Dh	2Bh	*1	*3	*5	*7	*9	03h		
Character	=	+	*2	*4	*6	*8	*10			

Acceptability

SECURITY	STANDBY	ECO STANDBY	NO SIGNAL	SHUTTER	FREEZE	TEST PATTERN	REMOTE2	P IN P	LENS HOME
	✓		✓	✓		✓	✓	✓	

3.225. BRIGHTNESS CONTROL - GAIN [VXX:TGA10]

Hexadecimal	02h	41h	44h	5Ah	5Ah	3Bh	56h	58h	58h	3Ah
Character		A	D	Z	Z	;	V	X	X	:
Hexadecimal	54h	47h	41h	49h	30h	3Dh	2Bh	*1	*3	*5
Character	T	G	A	I	0	=	+	*2	*4	*6
Hexadecimal	*7	*9	03h							
Character	*8	*10								

■ Parameters (*1,*2,*3,*4,*5,*6,*7,*8,*9,*10)

	20%					21%				
Hexadecimal	30h	30h	30h	32h	30h	30h	30h	30h	32h	31h
Character	0	0	0	2	0	0	0	0	2	1
	99%					100%				
Hexadecimal	30h	30h	30h	39h	39h	30h	30h	31h	30h	30h
Character	0	0	0	9	9	0	0	1	0	0

■ Response (Callback)

In the period when the command can be accepted

Hexadecimal	02h	56h	58h	58h	3Ah	54h	47h	41h	49h	30h
Character		V	X	X	:	T	G	A	I	0
Hexadecimal	3Dh	2Bh	*1	*3	*5	*7	*9	03h		
Character	=	+	*2	*4	*6	*8	*10			

Acceptability

SECURITY	STANDBY	ECO STANDBY	NO SIGNAL	SHUTTER	FREEZE	TEST PATTERN	REMOTE2	P IN P	LENS HOME
	✓		✓	✓	✓	✓	✓	✓	

3.226. BRIGHTNESS CONTROL - MODE [VXX:BCMI0]

Hexadecimal	02h	41h	44h	5Ah	5Ah	3Bh	56h	58h	58h	3Ah
Character		A	D	Z	Z	;	V	X	X	:
Hexadecimal	42h	43h	4Dh	49h	30h	3Dh	2Bh	*1	*3	*5
Character	B	C	M	I	0	=	+	*2	*4	*6
Hexadecimal	*7	*9	03h							
Character	*8	*10								

■ Parameters (*1,*2,*3,*4,*5,*6,*7,*8,*9,*10)

	OFF					AUTO				
Hexadecimal	30h	30h	30h	30h	30h	30h	30h	30h	30h	31h
Character	0	0	0	0	0	0	0	0	0	1
	PC									
Hexadecimal	30h	30h	30h	30h	32h					
Character	0	0	0	0	2					

■ Response (Callback)

In the period when the command can be accepted

Hexadecimal	02h	56h	58h	58h	3Ah	42h	43h	4Dh	49h	30h
Character		V	X	X	:	B	C	M	I	0
Hexadecimal	3Dh	2Bh	*1	*3	*5	*7	*9	03h		
Character	=	+	*2	*4	*6	*8	*10			

Acceptability

SECURITY	STANDBY	ECO STANDBY	NO SIGNAL	SHUTTER	FREEZE	TEST PATTERN	REMOTE2	P IN P	LENS HOME
			✓	✓	✓	✓	✓	✓	

3.227. BRIGHTNESS CONTROL - LINK [VXX:BCLI0]

Hexadecimal	02h	41h	44h	5Ah	5Ah	3Bh	56h	58h	58h	3Ah
Character		A	D	Z	Z	;	V	X	X	:
Hexadecimal	42h	43h	4Ch	49h	30h	3Dh	2Bh	*1	*3	*5
Character	B	C	L	I	0	=	+	*2	*4	*6
Hexadecimal	*7	*9	03h							
Character	*8	*10								

■ Parameters (*1,*2,*3,*4,*5,*6,*7,*8,*9,*10)

	OFF					GROUP A				
Hexadecimal	30h	30h	30h	30h	30h	30h	30h	30h	30h	31h
Character	0	0	0	0	0	0	0	0	0	1
	GROUP B					GROUP C				
Hexadecimal	30h	30h	30h	30h	32h	30h	30h	30h	30h	33h
Character	0	0	0	0	2	0	0	0	0	3
	GROUP D									
Hexadecimal	30h	30h	30h	30h	34h					
Character	0	0	0	0	4					

■ Response (Callback)

In the period when the command can be accepted

Hexadecimal	02h	56h	58h	58h	3Ah	42h	43h	4Ch	49h	30h
Character		V	X	X	:	B	C	L	l	0
Hexadecimal	3Dh	2Bh	*1	*3	*5	*7	*9	03h		
Character	=	+	*2	*4	*6	*8	*10			

Acceptability

SECURITY	STANDBY	ECO STANDBY	NO SIGNAL	SHUTTER	FREEZE	TEST PATTERN	REMOTE2	P IN P	LENS HOME
			✓	✓	✓	✓	✓	✓	

3.228. BRIGHTNESS CONTROL - CALIBRATION TIME [VXX:BTM1]

Hexadecimal	02h	41h	44h	5Ah	5Ah	3Bh	56h	58h	58h	3Ah
Character		A	D	Z	Z	;	V	X	X	:
Hexadecimal	42h	54h	4Dh	49h	31h	3Dh	2Bh	*1	*3	*5
Character	B	T	M	l	1	=	+	*2	*4	*6
Hexadecimal	*7	*9	03h							
Character	*8	*10								

■ Parameters (*1,*2,*3,*4,*5,*6,*7,*8,*9,*10)

	OFF					00:01				
Hexadecimal	30h	30h	30h	30h	30h	30h	30h	30h	30h	31h
Character	0	0	0	0	0	0	0	0	0	1
	23:59					00:00				
Hexadecimal	30h	32h	33h	35h	39h	30h	32h	34h	30h	30h
Character	0	2	3	5	9	0	2	4	0	0

■ Response (Callback)

In the period when the command can be accepted

Hexadecimal	02h	56h	58h	58h	3Ah	42h	54h	4Dh	49h	31h
Character		V	X	X	:	B	T	M	l	1
Hexadecimal	3Dh	2Bh	*1	*3	*5	*7	*9	03h		
Character	=	+	*2	*4	*6	*8	*10			

受 Acceptability

SECURITY	STANDBY	ECO STANDBY	NO SIGNAL	SHUTTER	FREEZE	TEST PATTERN	REMOTE2	P IN P	LENS HOME
			✓	✓	✓	✓	✓	✓	

3.229. BRIGHTNESS CONTROL - CALIBRATION MESSAGE [VXX:BMGI1]

Hexadecimal	02h	41h	44h	5Ah	5Ah	3Bh	56h	58h	58h	3Ah
Character		A	D	Z	Z	;	V	X	X	:
Hexadecimal	42h	4Dh	47h	49h	31h	3Dh	2Bh	*1	*3	*5
Character	B	M	G	l	1	=	+	*2	*4	*6
Hexadecimal	*7	*9	03h							
Character	*8	*10								

■ Parameters (*1,*2,*3,*4,*5,*6,*7,*8,*9,*10)

	OFF					ON				
Hexadecimal	30h	30h	30h	30h	30h	30h	30h	30h	30h	31h
Character	0	0	0	0	0	0	0	0	0	1

■ Response (Callback)

In the period when the command can be accepted

Hexadecimal	02h	56h	58h	58h	3Ah	42h	4Dh	47h	49h	31h
Character		V	X	X	:	B	M	G	l	1
Hexadecimal	3Dh	2Bh	*1	*3	*5	*7	*9	03h		
Character	=	+	*2	*4	*6	*8	*10			

Acceptability

SECURITY	STANDBY	ECO STANDBY	NO SIGNAL	SHUTTER	FREEZE	TEST PATTERN	REMOTE2	P IN P	LENS HOME
			✓	✓	✓	✓	✓	✓	

3.230. BRIGHTNESS CONTROL - START [VXX:BCSI0]

Hexadecimal	02h	41h	44h	5Ah	5Ah	3Bh	56h	58h	58h	3Ah
Character		A	D	Z	Z	;	V	X	X	:
Hexadecimal	42h	43h	53h	49h	30h	3Dh	2Bh	*1	*3	*5
Character	B	C	S	l	0	=	+	*2	*4	*6
Hexadecimal	*7	*9	03h							
Character	*8	*10								

■ Parameters (*1,*2,*3,*4,*5,*6,*7,*8,*9,*10)

	START				
Hexadecimal	30h	30h	30h	30h	31h
Character	0	0	0	0	1

■ Response (Callback)

In the period when the command can be accepted

Hexadecimal	02h	56h	58h	58h	3Ah	42h	43h	53h	49h	30h
Character		V	X	X	:	B	C	S	I	0
Hexadecimal	3Dh	2Bh	*1	*3	*5	*7	*9	03h		
Character	=	+	*2	*4	*6	*8	*10			

Acceptability

SECURITY	STANDBY	ECO STANDBY	NO SIGNAL	SHUTTER	FREEZE	TEST PATTERN	REMOTE2	P IN P	LENS HOME
			✓	✓	✓	✓	✓	✓	

3.231. STANDBY MODE [VXX:STMI0]

Hexadecimal	02h	41h	44h	5Ah	5Ah	3Bh	56h	58h	58h	3Ah
Character		A	D	Z	Z	;	V	X	X	:
Hexadecimal	53h	54h	4Dh	49h	30h	3Dh	2Bh	*1	*3	*5
Character	S	T	M	I	0	=	+	*2	*4	*6
Hexadecimal	*7	*9	03h							
Character	*8	*10								

■ Parameters (*1,*2,*3,*4,*5,*6,*7,*8,*9,*10)

	NOMAL					ECO				
Hexadecimal	30h	30h	30h	30h	30h	30h	30h	30h	30h	33h
Character	0	0	0	0	0	0	0	0	0	3

■ Response (Callback)

In the period when the command can be accepted

Hexadecimal	02h	56h	58h	58h	3Ah	53h	54h	4Dh	49h	30h
Character		V	X	X	:	S	T	M	I	0
Hexadecimal	3Dh	2Bh	*1	*3	*5	*7	*9	03h		
Character	=	+	*2	*4	*6	*8	*10			

Acceptability

SECURITY	STANDBY	ECO STANDBY	NO SIGNAL	SHUTTER	FREEZE	TEST PATTERN	REMOTE2	P IN P	LENS HOME
	✓	✓	✓	✓	✓	✓	✓	✓	

3.232. SCHEDULE [VXX:SCH10]

Hexadecimal	02h	41h	44h	5Ah	5Ah	3Bh	56h	58h	58h	3Ah
Character		A	D	Z	Z	;	V	X	X	:
Hexadecimal	53h	43h	48h	49h	30h	3Dh	2Bh	*1	*3	*5
Character	S	C	H	I	0	=	+	*2	*4	*6
Hexadecimal	*7	*9	03h							
Character	*8	*10								

■ Parameters (*1,*2,*3,*4,*5,*6,*7,*8,*9,*10)

	OFF					ON				
Hexadecimal	30h	30h	30h	30h	30h	30h	30h	30h	30h	31h
Character	0	0	0	0	0	0	0	0	0	1

■ Response (Callback)

In the period when the command can be accepted

Hexadecimal	02h	56h	58h	58h	3Ah	53h	43h	48h	49h	30h
Character		V	X	X	:	S	C	H	I	0
Hexadecimal	3Dh	2Bh	*1	*3	*5	*7	*9	03h		
Character	=	+	*2	*4	*6	*8	*10			

Acceptability

SECURITY	STANDBY	ECO STANDBY	NO SIGNAL	SHUTTER	FREEZE	TEST PATTERN	REMOTE2	P IN P	LENS HOME
	✓		✓	✓		✓	✓	✓	

3.233. SCHEDULE - PROGRAM ASSIGN [VXX:SPGI]

Hexadecimal	02h	41h	44h	5Ah	5Ah	3Bh	56h	58h	58h	3Ah
Character		A	D	Z	Z	;	V	X	X	:
Hexadecimal	53h	50h	47h	49h	*1	3Dh	2Bh	*3	*5	*7
Character	S	P	G	I	*2	=	+	*4	*6	*8
Hexadecimal	*9	*11	03h							
Character	*10	*12								

■ Parameters (*1,*2)

	Sun	Mon	Tue	Wed	Thu	Fri	Sat
Hexadecimal	30h	31h	32h	33h	34h	35h	36h
Character	0	1	2	3	4	5	6

■ Parameters (*3, *4, *5, *6, *7, *8, *9, *10, *11, *12)

	OFF					PROGRAM 1					PROGRAM 2				
Hexadecimal	30h	30h	30h	30h	30h	30h	30h	30h	30h	31h	30h	30h	30h	30h	32h
Character	0	0	0	0	0	0	0	0	0	1	0	0	0	0	2
	PROGRAM 3				PROGRAM 4				PROGRAM 5						
Hexadecimal	30h	30h	30h	30h	33h	30h	30h	30h	30h	34h	30h	30h	30h	30h	35h
Character	0	0	0	0	3	0	0	0	0	4	0	0	0	0	5
	PROGRAM 6				PROGRAM 7										
Hexadecimal	30h	30h	30h	30h	36h	30h	30h	30h	30h	37h					
Character	0	0	0	0	6	0	0	0	0	7					

■ Response (Callback)

In the period when the command can be accepted

Hexadecimal	02h	56h	58h	58h	3Ah	53h	50h	47h	49h	*1
Character		V	X	X	:	S	P	G	I	*2
Hexadecimal	3Dh	2Bh	*3	*5	*7	*9	*11	03h		
Character	=	+	*4	*6	*8	*10	*12			

Acceptability

SECURITY	STANDBY	ECO STANDBY	NO SIGNAL	SHUTTER	FREEZE	TEST PATTERN	REMOTE2	P IN P	LENS HOME
	✓		✓	✓		✓	✓	✓	

3.234. SCHEDULE - SET COMMAND [VXX:SCCS]

Hexadecimal	02h	41h	44h	5Ah	5Ah	3Bh	56h	58h	58h	3Ah
Character		A	D	Z	Z	;	V	X	X	:
Hexadecimal	53h	43h	43h	53h	*1	3Dh	*3	*5	*7	*9
Character	S	C	C	S	*2	=	*4	*6	*8	*10
Hexadecimal	*11	*13	*15	*17	03h					
Character	*12	*14	*16	*18						

■ Parameters (*1, *2)

	PROGRAM 1	PROGRAM 2	PROGRAM 3	PROGRAM 4
Hexadecimal	31h	32h	33h	34h
Character	1	2	3	4
	PROGRAM 5	PROGRAM 6	PROGRAM 7	
Hexadecimal	35h	36h	37h	
Character	5	6	7	

■ Parameters (*3, *4, *5, *6)

	COMMAND 1	COMMAND 2	COMMAND 3	COMMAND 4
Hexadecimal	30h	31h	30h	32h
Character	0	1	0	2
	COMMAND 13	COMMAND 14	COMMAND 15	COMMAND 16
Hexadecimal	31h	33h	31h	34h
Character	1	3	1	4
Hexadecimal	31h	35h	31h	36h
Character	1	5	1	6

■ Parameters (*7, *8, *9, *10)

	Command Deleting		STANBY		PPOWER ON		SHUTTER Open		SHUTTER Colosed	
Hexadecimal	30h	30h	31h	30h	31h	31h	32h	30h	32h	31h
Character	0	0	1	0	1	1	2	0	2	1
	RGB1 INPUT		RGB2 INPUT		DVI INPUT		SDI INPUT		HDMI INPUT	
Hexadecimal	33h	31h	33h	32h	35h	31h	35h	32h	35h	33h
Character	3	1	3	2	5	1	5	2	5	3
	LAMP POWER NORMAL		LAMP POWER ECO		SINGLE LAMP		DUAL LAMP		DIGITAL LINK INPUT	
Hexadecimal	37h	30h	37h	31h	38h	31h	38h	33h	42h	30h
Character	7	0	7	1	8	1	8	2	B	0
	INPUT 1		INPUT 2		INPUT 3		INPUT 4		INPUT 5	
Hexadecimal	42h	31h	42h	32h	42h	33h	42h	34h	42h	35h
Character	B	1	B	2	B	3	B	4	B	5
	INPUT 6		INPUT 7		INPUT 8		INPUT 9		INPUT 10	
Hexadecimal	42h	36h	42h	37h	42h	38h	42h	39h	42h	3Ah
Character	B	6	B	7	B	8	B	9	B	A
	P IN P OFF		P IN P USER1		P IN P USER2		P IN P USER3			
Hexadecimal	39h	30h	39h	31h	39h	32h	39h	33h		
Character	9	0	9	1	9	2	9	3		

■ Parameters (*11, *12, *13, *14, *15, *16, *17, *18)

	00:00				00:01				00:02			
Hexadecimal	30h	30h	30h	30h	30h	30h	30h	31h	30h	30h	30h	32h
Character	0	0	0	0	0	0	0	1	0	0	0	2
	23:57				23:58				23:59			
Hexadecimal	32h	33h	35h	37h	32h	33h	35h	38h	32h	33h	35h	39h
Character	2	3	5	7	2	3	5	8	2	3	5	9

■ Response (Callback)

In the period when the command can be accepted

Hexadecimal	02h	56h	58h	58h	3Ah	53h	43h	43h	53h	*1	
Character		V	X	X	:	S	C	C	S	*2	
Hexadecimal	3Dh	2Bh	*3	*5	*7	*9	*11	*13	*15	*17	03h
Character	=	+	*4	*6	*8	*10	*12	*14	*16	*18	

Acceptability

SECURITY	STANDBY	ECO STANDBY	NO SIGNAL	SHUTTER	FREEZE	TEST PATTERN	REMOTE2	P IN P	LENS HOME
	✓		✓	✓		✓	✓	✓	

3.235. INITIAL STARTUP [OPY]

Hexadecimal	02h	41h	44h	5Ah	5Ah	3Bh	4Fh	50h	59h	3Ah	*1	03h
Character		A	D	Z	Z	;	O	P	Y	:	*2	

Parameters (*1,*2)

	STANDBY	ON	LAST MEMORY
Hexadecimal	30h	31h	32h
Character	0	1	2

■ Response (Callback)

In the period when the command can be accepted

Hexadecimal	02h	4Fh	50h	59h	3Ah	*1	03h
Character		O	P	Y	:	*2	

Acceptability

SECURITY	STANDBY	ECO STANDBY	NO SIGNAL	SHUTTER	FREEZE	TEST PATTERN	REMOTE2	P IN P	LENS HOME
	✓		✓	✓	✓	✓	✓	✓	

3.236. STARTUP INPUT SELECT [VXX:SISS1]

Hexadecimal	02h	41h	44h	5Ah	5Ah	3Bh	56h	58h	58h	3Ah
Character		A	D	Z	Z	;	V	X	X	:
Hexadecimal	53h	49h	53h	53h	31h	3Dh	*1	*3	*5	03h
Character	S	I	S	S	1	=	*2	*4	*6	

Parameters (*1,*2,*3,*4,*5,*6,*7,*8,*9,*10)

	RGB1			RGB2			DVI-D					
Hexadecimal	52h	47h	31h	52h	47h	32h	44h	56h	49h			
Character	R	G	1	R	G	2	D	V	I			
	HDMI			DIGITAL LINK			SDI			LAST USED		
Hexadecimal	48h	44h	31h	44h	4Ch	31h	53h	44h	31h	4Ch	53h	55h
Character	H	D	1	D	L	1	S	D	1	L	S	U

■ Response (Callback)

In the period when the command can be accepted

Hexadecimal	02h	56h	58h	58h	3Ah	53h	49h	53h	53h	31h
Character		V	X	X	:	S	I	S	S	1
Hexadecimal	3Dh	*1	*3	*5	03h					
Character	=	*2	*4	*6						

Acceptability

SECURITY	STANDBY	ECO STANDBY	NO SIGNAL	SHUTTER	FREEZE	TEST PATTERN	REMOTE2	P IN P	LENS HOME
	✓		✓	✓	✓	✓	✓	✓	

3.237. STARTUP INPUT SELECT (DIGITAL LINK) [VXX:SISI2]

Hexadecimal	02h	41h	44h	5Ah	5Ah	3Bh	56h	58h	58h	3Ah
Character		A	D	Z	Z	;	V	X	X	:
Hexadecimal	53h	49h	53h	53h	32h	3Dh	2Bh	*1	*3	*5
Character	S	I	S	S	2	=	+	*2	*4	*6
Hexadecimal	*7	*9	03h							
Character	*8	*10								

Parameters (*1,*2,*3,*4,*5,*6,*7,*8,*9,*10)

	LAST USED					INPUT 1				
Hexadecimal	30h	30h	30h	30h	30h	30h	30h	30h	30h	31h
Character	0	0	0	0	0	0	0	0	0	1
	INPUT 2					INPUT 3				
Hexadecimal	30h	30h	30h	30h	32h	30h	30h	30h	30h	33h
Character	0	0	0	0	2	0	0	0	0	3
	INPUT 4					INPUT 5				
Hexadecimal	30h	30h	30h	30h	34h	30h	30h	30h	30h	35h
Character	0	0	0	0	4	0	0	0	0	5
	INPUT 6					INPUT 7				
Hexadecimal	30h	30h	30h	30h	36h	30h	30h	30h	30h	37h
Character	0	0	0	0	6	0	0	0	0	7

		INPUT 8					INPUT 9				
Hexadecimal		30h	30h	30h	30h	38h	30h	30h	30h	30h	39h
Character		0	0	0	0	8	0	0	0	0	9
		INPUT 10									
Hexadecimal		30h	30h	30h	31h	30h					
Character		0	0	0	1	0					

■ Response (Callback)

In the period when the command can be accepted

Hexadecimal	02h	56h	58h	58h	3Ah	53h	49h	53h	53h	32h
Character		V	X	X	:	S	I	S	S	2
Hexadecimal	3Dh	2Bh	*1	*3	*5	*7	*9	03h		
Character	=	+	*2	*4	*6	*8	*10			

Acceptability

SECURITY	STANDBY	ECO STANDBY	NO SIGNAL	SHUTTER	FREEZE	TEST PATTERN	REMOTE2	P IN P	LENS HOME
✓	✓		✓	✓	✓	✓	✓	✓	✓

3.238. NO SIGNAL SHUT - OFF [OAF]

Hexadecimal	02h	41h	44h	5Ah	5Ah	3Bh	4Fh	41h	46h	3Ah
Character		A	D	Z	Z	:	O	A	F	:
Hexadecimal	*1	*3	03h							
Character	*2	*4								

■ Parameters (*1,*2,*3,*4)

		DISABLE		10MIN		20MIN		30MIN		40MIN	
Hexadecimal		30h	30h	31h	30h	32h	30h	33h	30h	34h	30h
Character		0	0	1	0	2	0	3	0	4	0
		50MIN		60MIN		70MIN		80MIN		90MIN	
Hexadecimal		35h	30h	36h	30h	37h	30h	38h	30h	39h	30h
Character		5	0	6	0	7	0	8	0	9	0

■ Response (Callback)

In the period when the command can be accepted

Hexadecimal	02h	44h	41h	46h	3Ah	*1	*3	03h
Character		O	A	F	:	*2	*4	

Acceptability

SECURITY	STANDBY	ECO STANDBY	NO SIGNAL	SHUTTER	FREEZE	TEST PATTERN	REMOTE2	P IN P	LENS HOME
	✓		✓	✓	✓	✓	✓	✓	

3.239. FUNCTION [OFC]

Hexadecimal	02h	41h	44h	5Ah	5Ah	3Bh	4Fh	46h	43h	3Ah	*1	03h
Character		A	D	Z	Z	:	O	F	C	:	*2	

Parameters (*1,*2)

		DISABLE		SYSTEM SELECTOR		SYSTEM DAYLIGHT VIEW		SUB MEMORY	
Hexadecimal		30h		31h		32h		33h	
Character		0		1		2		3	
		FREEZE		P IN P		WAVEFORM MONITOR		ASPECT	
Hexadecimal		34h		35h		36h		39h	
Character		4		5		6		9	

■ Response (Callback)

In the period when the command can be accepted

Hexadecimal	02h	4Fh	46h	43h	3Ah	*1	03h
Character		O	F	C	:	*2	

Acceptability

SECURITY	STANDBY	ECO STANDBY	NO SIGNAL	SHUTTER	FREEZE	TEST PATTERN	REMOTE2	P IN P	LENS HOME
	✓		✓	✓	✓	✓	✓	✓	

3.240. DATE AND TIME - ADJUST CLOCK DATE [TSD]

Hexadecimal	02h	41h	44h	5Ah	5Ah	3Bh	54h	53h	44h	3Ah
Character		A	D	Z	Z	:	T	S	D	:
Hexadecimal	*y1	*y2	*y3	*y4	*m1	*m2	*d1	*d2	*w	03h
Character										

■ Parameters

*y1~*y4 : Year (4 digits),

*m1~*m2 : Month (2 digits)

*d1~*d2 : Day (2 digits)

*w : Day of the week (Mon=1, Tue=2, Wed=3, Thu=4, Fri=5, Sat=6, Sun=7)

Set it by UTC (Coordinated Universal Time)

Example: Thursday, August 17, 2010

	*y1	*y2	*y3	*y4	*m1	*m2	*d1	*d2	*w
Hexadecimal	32h	30h	31h	30h	30h	38h	31h	37h	32h
Character	2	0	1	0	0	8	1	7	2

■ Response (Callback)

In the period when the command can be accepted

Hexadecimal	02h	54h	53h	44h	3Ah	*y1	*y2		
Character		T	S	D	:				
Hexadecimal	*y3	*y4	*m1	*m2	*d1	*d2	*w	03h	
Character									

Acceptability

SECURITY	STANDBY	ECO STANDBY	NO SIGNAL	SHUTTER	FREEZE	TEST PATTERN	REMOTE2	P IN P	LENS HOME
	✓		✓	✓		✓	✓	✓	

3.241. DATE AND TIME - ADJUST CLOCK TIME [TST]

Hexadecimal	02h	41h	44h	5Ah	5Ah	3Bh	54h	53h	54h	3Ah
Character		A	D	Z	Z	:	T	S	T	:
Hexadecimal	*h1	*h2	*m1	*m2	*s1	*s2	03h			
Character										

■ Parameters

*h1~*h2 : Hour (2 digits)

*m1~*m2 : Minute (2 digits)

*s1~*s2 : Second (2 digits)

Set it by UTC (Coordinated Universal Time)

Example: 3 seconds at 3:45 p.m

	*h1	*h2	*m1	*m2	*s1	*s2
Hexadecimal	31h	35h	34h	35h	30h	33h
Character	1	5	4	5	0	3

■ Response (Callback)

In the period when the command can be accepted

Hexadecimal	02h	54h	53h	54h	3Ah			
Character		T	S	T	:			
Hexadecimal	*h1	*h2	*m1	*m2	*s1	*s2	03h	
Character								

Acceptability

SECURITY	STANDBY	ECO STANDBY	NO SIGNAL	SHUTTER	FREEZE	TEST PATTERN	REMOTE2	P IN P	LENS HOME
	✓		✓	✓		✓	✓	✓	

3.242. DATE AND TIME - NTP SYNCHRONIZATION [VXX:NTPIO]

Hexadecimal	02h	41h	44h	5Ah	5Ah	3Bh	56h	58h	58h	3Ah
Character		A	D	Z	Z	:	V	X	X	:
Hexadecimal	4Eh	54h	50h	49h	30h	3Dh	2Bh	*1	*3	*5
Character	N	T	P	l	0	=	+	*2	*4	*6
Hexadecimal	*7	*9	03h							
Character	*8	*10								

■ Parameters (*1,*2,*3,*4,*5,*6,*7,*8,*9,*10)

	OFF					ON				
Hexadecimal	30h	30h	30h	30h	30h	30h	30h	30h	30h	31h
Character	0	0	0	0	0	0	0	0	0	1

■ Response (Callback)

In the period when the command can be accepted

Hexadecimal	02h	56h	58h	58h	3Ah	4Eh	54h	50h	49h	30h
Character		V	X	X	:	N	T	P	l	0
Hexadecimal	3Dh	2Bh	*1	*3	*5	*7	*9	03h		
Character	=	+	*2	*4	*6	*8	*10			

Acceptability

SECURITY	STANDBY	ECO STANDBY	NO SIGNAL	SHUTTER	FREEZE	TEST PATTERN	REMOTE2	P IN P	LENS HOME
	✓		✓	✓		✓	✓	✓	

3.243. LENS CALIBRATION [VXX:LNSIO]

Hexadecimal	02h	41h	44h	5Ah	5Ah	3Bh	56h	58h	58h	3Ah
Character		A	D	Z	Z	:	V	X	X	:
Hexadecimal	4Ch	4Eh	53h	49h	30h	3Dh	2Bh	*1	*3	*5
Character	L	N	S	l	0	=	+	*2	*4	*6
Hexadecimal	*7	*9	03h							
Character	*8	*10								

■ Parameters (*1,*2,*3,*4,*5,*6,*7,*8,*9,*10)

	Execution				
Hexadecimal	30h	30h	30h	30h	31h
Character	0	0	0	0	1

■ Response (Callback)

In the period when the command can be accepted

Hexadecimal	02h	56h	58h	58h	3Ah	4Ch	4Eh	53h	49h	30h
Character		V	X	X	:	L	N	S	I	0
Hexadecimal	3Dh	2Bh	*1	*3	*5	*7	*9	03h		
Character	=	+	*2	*4	*6	*8	*10			

Acceptability

SECURITY	STANDBY	ECO STANDBY	NO SIGNAL	SHUTTER	FREEZE	TEST PATTERN	REMOTE2	P IN P	LENS HOME
			✓		✓	✓	✓	✓	

3.244. LENS HOME POSITION [VXX:LNS11]

Hexadecimal	02h	41h	44h	5Ah	5Ah	3Bh	56h	58h	58h	3Ah
Character		A	D	Z	Z	;	V	X	X	:
Hexadecimal	4Ch	4Eh	53h	49h	31h	3Dh	2Dh	*1	*3	*5
Character	L	N	S	I	1	=	+	*2	*4	*6
Hexadecimal	*7	*9	03h							
Character	*8	*10								

■ Parameters (*1,*2,*3,*4,*5,*6,*7,*8,*9,*10)

	Execution				
Hexadecimal	30h	30h	30h	30h	31h
Character	0	0	0	0	1

■ Response (Callback)

In the period when the command can be accepted

Hexadecimal	02h	56h	58h	58h	3Ah	4Ch	4Eh	53h	49h	31h
Character		V	X	X	:	L	N	S	I	1
Hexadecimal	3Dh	2Bh	*1	*3	*5	*7	*9	03h		
Character	=	+	*2	*4	*6	*8	*10			

Acceptability

SECURITY	STANDBY	ECO STANDBY	NO SIGNAL	SHUTTER	FREEZE	TEST PATTERN	REMOTE2	P IN P	LENS HOME
			✓		✓	✓	✓	✓	

3.245. LENS SHIFT - HORIZONTAL [VXX:LNSI2]

Hexadecimal	02h	41h	44h	5Ah	5Ah	3Bh	56h	58h	58h	3Ah
Character		A	D	Z	Z	;	V	X	X	:
Hexadecimal	4Ch	4Eh	53h	49h	32h	3Dh	2Bh	*1	*3	*5
Character	L	N	S	I	2	=	+	*2	*4	*6
Hexadecimal	*7	*9	03h							
Character	*8	*10								

■ Parameters (*1,*2,*3,*4,*5,*6,*7,*8,*9,*10)

	Slow : +					Slow : -				
Hexadecimal	30h	30h	30h	30h	30h	30h	30h	30h	30h	31h
Character	0	0	0	0	0	0	0	0	0	1
	Normal : +					Normal : -				
Hexadecimal	30h	30h	31h	30h	30h	30h	30h	31h	30h	31h
Character	0	0	1	0	0	0	0	1	0	1
	Fast : +					Fast : -				
Hexadecimal	30h	30h	32h	30h	30h	30h	30h	32h	30h	31h
Character	0	0	2	0	0	0	0	2	0	1

■ Response (Callback)

In the period when the command can be accepted

Hexadecimal	02h	56h	58h	58h	3Ah	4Ch	4Eh	53h	49h	32h
Character		V	X	X	:	L	N	S	I	2
Hexadecimal	3Dh	2Bh	*1	*3	*5	*7	*9	03h		
Character	=	+	*2	*4	*6	*8	*10			

Acceptability

SECURITY	STANDBY	ECO STANDBY	NO SIGNAL	SHUTTER	FREEZE	TEST PATTERN	REMOTE2	P IN P	LENS HOME
			✓		✓	✓	✓	✓	

3.246. LENS SHIFT - VERTICAL [VXX:LNSI3]

Hexadecimal	02h	41h	44h	5Ah	5Ah	3Bh	56h	58h	58h	3Ah
Character		A	D	Z	Z	;	V	X	X	:
Hexadecimal	4Ch	4Eh	53h	49h	33h	3Dh	2Bh	*1	*3	*5
Character	L	N	S	I	3	=	+	*2	*4	*6
Hexadecimal	*7	*9	03h							
Character	*8	*10								

■ Parameters (*1,*2,*3,*4,*5,*6,*7,*8,*9,*10)

	Slow : +					Slow : -				
Hexadecimal	30h	30h	30h	30h	30h	30h	30h	30h	30h	31h
Character	0	0	0	0	0	0	0	0	0	1
	Normal : +					Normal : -				
Hexadecimal	30h	30h	31h	30h	30h	30h	30h	31h	30h	31h
Character	0	0	1	0	0	0	0	1	0	1
	Fast : +					Fast : -				
Hexadecimal	30h	30h	32h	30h	30h	30h	30h	32h	30h	31h
Character	0	0	2	0	0	0	0	2	0	1

■ Response (Callback)

In the period when the command can be accepted

Hexadecimal	02h	56h	58h	58h	3Ah	4Ch	4Eh	53h	49h	33h
Character		V	X	X	:	L	N	S	I	3
Hexadecimal	3Dh	2Bh	*1	*3	*5	*7	*9	03h		
Character	=	+	*2	*4	*6	*8	*10			

Acceptability

SECURITY	STANDBY	ECO STANDBY	NO SIGNAL	SHUTTER	FREEZE	TEST PATTERN	REMOTE2	P IN P	LENS HOME
			✓		✓	✓	✓	✓	

3.247. LENS FOCUS [VXX:LNSI4]

Hexadecimal	02h	41h	44h	5Ah	5Ah	3Bh	56h	58h	58h	3Ah
Character		A	D	Z	Z	;	V	X	X	:
Hexadecimal	4Ch	4Eh	53h	49h	34h	3Dh	2Bh	*1	*3	*5
Character	L	N	S	I	4	=	+	*2	*4	*6
Hexadecimal	*7	*9	03h							
Character	*8	*10								

■ Parameters (*1,*2,*3,*4,*5,*6,*7,*8,*9,*10)

	Slow : +					Slow : -				
Hexadecimal	30h	30h	30h	30h	30h	30h	30h	30h	30h	31h
Character	0	0	0	0	0	0	0	0	0	1
	Normal : +					Normal : -				
Hexadecimal	30h	30h	31h	30h	30h	30h	30h	31h	30h	31h
Character	0	0	1	0	0	0	0	1	0	1
	Fast : +					Fast : -				
Hexadecimal	30h	30h	32h	30h	30h	30h	30h	32h	30h	31h
Character	0	0	2	0	0	0	0	2	0	1

■ Response (Callback)

In the period when the command can be accepted

Hexadecimal	02h	56h	58h	58h	3Ah	4Ch	4Eh	53h	49h	34h
Character		V	X	X	:	L	N	S	I	4
Hexadecimal	3Dh	2Bh	*1	*3	*5	*7	*9	03h		
Character	=	+	*2	*4	*6	*8	*10			

Acceptability

SECURITY	STANDBY	ECO STANDBY	NO SIGNAL	SHUTTER	FREEZE	TEST PATTERN	REMOTE2	P IN P	LENS HOME
			✓		✓	✓	✓	✓	

3.248. LENS ZOOM [VXX:LNSI5]

Hexadecimal	02h	41h	44h	5Ah	5Ah	3Bh	56h	58h	58h	3Ah
Character		A	D	Z	Z	;	V	X	X	:
Hexadecimal	4Ch	4Eh	53h	49h	35h	3Dh	2Bh	*1	*3	*5
Character	L	N	S	I	5	=	+	*2	*4	*6
Hexadecimal	*7	*9	03h							
Character	*8	*10								

■ Parameters (*1,*2,*3,*4,*5,*6,*7,*8,*9,*10)

	Slow : +					Slow : -				
Hexadecimal	30h	30h	30h	30h	30h	30h	30h	30h	30h	31h
Character	0	0	0	0	0	0	0	0	0	1
	Normal : +					Normal : -				
Hexadecimal	30h	30h	31h	30h	30h	30h	30h	31h	30h	31h
Character	0	0	1	0	0	0	0	1	0	1

	Fast : +					Fast : -				
Hexadecimal	30h	30h	32h	30h	30h	30h	30h	32h	30h	31h
Character	0	0	2	0	0	0	0	2	0	1

■ Response (Callback)

In the period when the command can be accepted

Hexadecimal	02h	56h	58h	58h	3Ah	4Ch	4Eh	53h	49h	35h
Character		V	X	X	:	L	N	S	I	5
Hexadecimal	3Dh	2Bh	*1	*3	*5	*7	*9	03h		
Character	=	+	*2	*4	*6	*8	*10			

Acceptability

SECURITY	STANDBY	ECO STANDBY	NO SIGNAL	SHUTTER	FREEZE	TEST PATTERN	REMOTE2	P IN P	LENS HOME
			✓		✓	✓	✓	✓	

3.249. LENS TYPE [VXX:LNSI6]

Hexadecimal	02h	41h	44h	5Ah	5Ah	3Bh	56h	58h	58h	3Ah
Character		A	D	Z	Z	;	V	X	X	:
Hexadecimal	4Ch	4Eh	53h	49h	36h	3Dh	2Dh	*1	*3	*5
Character	L	N	S	I	6	=	+	*2	*4	*6
Hexadecimal	*7	*9	03h							
Character	*8	*10								

■ Parameters (*1,*2,*3,*4,*5,*6,*7,*8,*9,*10)

	NORMAL					DLE030				
Hexadecimal	30h	30h	30h	30h	31h	30h	30h	30h	30h	31h
Character	0	0	0	0	1	0	0	0	0	1

■ Response (Callback)

In the period when the command can be accepted

Hexadecimal	02h	56h	58h	58h	3Ah	4Ch	4Eh	53h	49h	36h
Character		V	X	X	:	L	N	S	I	6
Hexadecimal	3Dh	2Bh	*1	*3	*5	*7	*9	03h		
Character	=	+	*2	*4	*6	*8	*10			

Acceptability

SECURITY	STANDBY	ECO STANDBY	NO SIGNAL	SHUTTER	FREEZE	TEST PATTERN	REMOTE2	P IN P	LENS HOME
			✓		✓	✓	✓	✓	

3.250. INITIALIZE - ALL USER DATA [VXX:RSTS1]

Hexadecimal	02h	41h	44h	5Ah	5Ah	3Bh	56h	58h	58h	3Ah
Character		A	D	Z	Z	;	V	X	X	:
Hexadecimal	52h	53h	54h	53h	31h	3Dh	*1	*3	...	*5
Character	R	S	T	S	1	=	*2	*4	...	*6
Hexadecimal	03h									
Character										

■ Parameters (*1,*2)

	INITIALIZE USER DATA	LOAD USER DATA
Hexadecimal	30h	31h
Character	0	1

■ Parameters (*3,*4,*5,*6)

	SECURITY PASSWORD		
Hexadecimal	X1h	...	Xnh
Character		...	

■ Response (Callback)

In the period when the command can be accepted

Hexadecimal	02h	56h	58h	58h	3Ah	52h	53h	54h	53h	31h
Character		V	X	X	:	R	S	T	S	1
Hexadecimal	3Dh	X1h	...	Xnh						
Character	=		...							

Acceptability

SECURITY	STANDBY	ECO STANDBY	NO SIGNAL	SHUTTER	FREEZE	TEST PATTERN	REMOTE2	P IN P	LENS HOME
✓	✓		✓	✓	✓	✓	✓	✓	

■ Note:

- The projector will go into the standby status to reflect the setting values.

3.251. NETWORK SETUP - PROJECTOR NAME [VXX:NCGS8]

Hexadecimal	02h	41h	44h	5Ah	5Ah	3Bh	56h	58h	58h	3Ah
Character		A	D	Z	Z	;	V	X	X	:
Hexadecimal	4Eh	43h	47h	53h	38h	3Dh	*1	*3	*5	*7
Character	N	C	G	S	8	=	*2	*4	*6	*8
Hexadecimal	*9	*11	*13	*15	*17	*19	*21	*23	03h	
Character	*10	*12	*14	*16	*18	*20	*22	*24		

■ Parameters (*1,*2,...,*23,*24)

	Name					
Hexadecimal	n1h	n2h	n3h	...	n11h	n12h
Character	p1	p2	p3	...	p11	p12

■ Response (Callback)

In the period when the command can be accepted

Hexadecimal	02h	56h	58h	58h	3Ah	4Eh	43h	47h	53h	38h
Character		V	X	X	:	N	C	G	S	8
Hexadecimal	3Dh	*1	*3	*5	*7	*9	*11	*13	*15	*17
Character	=	*2	*4	*6	*8	*10	*12	*14	*16	*18
Hexadecimal	*19	*21	*23	03h						
Character	*20	*22	*24							

Acceptability

SECURITY	STANDBY	ECO STANDBY	NO SIGNAL	SHUTTER	FREEZE	TEST PATTERN	REMOTE2	P IN P	LENS HOME
	✓		✓	✓	✓	✓	✓	✓	

■ Note:

· Name is set by the undefined length. (It is necessary more than one character)

3.252. DIGITAL LINK MODE [VXX:DKMI1]

Hexadecimal	02h	41h	44h	5Ah	5Ah	3Bh	56h	58h	58h	3Ah
Character		A	D	Z	Z	;	V	X	X	:
Hexadecimal	44h	4Bh	4Dh	49h	31h	3Dh	2Bh	*1	*3	*5
Character	D	K	M	l	1	=	+	*2	*4	*6
Hexadecimal	*7	*9	03h							
Character	*8	*10								

■ Parameters (*1,*2,*3,*4,*5,*6,*7,*8,*9,*10)

	AUTO					DIGITAL LINK				
Hexadecimal	30h	30h	30h	30h	31h	30h	30h	30h	30h	32h
Character	0	0	0	0	1	0	0	0	0	2
	ETHERNET					LONG REACH				
Hexadecimal	30h	30h	30h	30h	33h	30h	30h	30h	30h	34h
Character	0	0	0	0	3	0	0	0	0	4

■ Response (Callback)

In the period when the command can be accepted

Hexadecimal	02h	56h	58h	58h	3Ah	44h	4Bh	4Dh	49h	31h
Character		V	X	X	:	D	K	M	l	1
Hexadecimal	3Dh	2Bh	*1	*3	*5	*7	*9	03h		
Character	=	+	*2	*4	*6	*8	*10			

Acceptability

SECURITY	STANDBY	ECO STANDBY	NO SIGNAL	SHUTTER	FREEZE	TEST PATTERN	REMOTE2	P IN P	LENS HOME
	✓		✓	✓	✓	✓	✓	✓	

3.253. DIGITAL LINK SETUP - DUPLEX (ETHERNET) [VXX:DKDI1]

Hexadecimal	02h	41h	44h	5Ah	5Ah	3Bh	56h	58h	58h	3Ah
Character		A	D	Z	Z	;	V	X	X	:
Hexadecimal	44h	4Bh	44h	49h	31h	3Dh	2Bh	*1	*3	*5
Character	D	K	D	l	1	=	+	*2	*4	*6
Hexadecimal	*7	*9	03h							
Character	*8	*10								

■ Parameters (*1,*2,*3,*4,*5,*6,*7,*8,*9,*10)

	AUTO NEGOTIATION					100BaseTX-Full				
Hexadecimal	30h	30h	30h	30h	30h	30h	30h	30h	30h	31h
Character	0	0	0	0	0	0	0	0	0	1
	100BaseTX-Half									
Hexadecimal	30h	30h	30h	30h	32h					
Character	0	0	0	0	2					

■ Response (Callback)

In the period when the command can be accepted

Hexadecimal	02h	56h	58h	58h	3Ah	44h	4Bh	44h	49h	31h
Character		V	X	X	:	D	K	D	I	1
Hexadecimal	3Dh	2Bh	*1	*3	*5	*7	*9	03h		
Character	=	+	*2	*4	*6	*8	*10			

Acceptability

SECURITY	STANDBY	ECO STANDBY	NO SIGNAL	SHUTTER	FREEZE	TEST PATTERN	REMOTE2	P IN P	LENS HOME
	✓		✓	✓	✓	✓	✓	✓	

3.254. DIGITAL LINK SETUP - DUPLEX (DIGITAL LINK) [VXX:DKD12]

Hexadecimal	02h	41h	44h	5Ah	5Ah	3Bh	56h	58h	58h	3Ah
Character		A	D	Z	Z	;	V	X	X	:
Hexadecimal	44h	4Bh	44h	49h	32h	3Dh	2Bh	*1	*3	*5
Character	D	K	D	I	2	=	+	*2	*4	*6
Hexadecimal	*7	*9	03h							
Character	*8	*10								

■ Parameters (*1,*2,*3,*4,*5,*6,*7,*8,*9,*10)

	AUTO NEGOTIATION					100BaseTX-Full				
Hexadecimal	30h	30h	30h	30h	30h	30h	30h	30h	30h	31h
Character	0	0	0	0	0	0	0	0	0	1
	100BaseTX-Half									
Hexadecimal	30h	30h	30h	30h	32h					
Character	0	0	0	0	2					

■ Response (Callback)

In the period when the command can be accepted

Hexadecimal	02h	56h	58h	58h	3Ah	44h	4Bh	44h	49h	32h
Character		V	X	X	:	D	K	D	I	2
Hexadecimal	3Dh	2Bh	*1	*3	*5	*7	*9	03h		
Character	=	+	*2	*4	*6	*8	*10			

Acceptability

SECURITY	STANDBY	ECO STANDBY	NO SIGNAL	SHUTTER	FREEZE	TEST PATTERN	REMOTE2	P IN P	LENS HOME
	✓		✓	✓	✓	✓	✓	✓	

3.255. Art-Net SETUP [VXX:DANI1]

Hexadecimal	02h	41h	44h	5Ah	5Ah	3Bh	56h	58h	58h	3Ah
Character		A	D	Z	Z	;	V	X	X	:
Hexadecimal	44h	41h	4Eh	49h	31h	3Dh	2Bh	*1	*3	*5
Character	D	A	N	I	1	=	+	*2	*4	*6
Hexadecimal	*7	*9	03h							
Character	*8	*10								

■ Parameters (*1,*2,*3,*4,*5,*6,*7,*8,*9,*10)

	OFF					ON (2.X.X.X)				
Hexadecimal	30h	30h	30h	30h	30h	30h	30h	30h	30h	32h
Character	0	0	0	0	0	0	0	0	0	2
	ON (10.X.X.X)					ON (MANUAL)				
Hexadecimal	30h	30h	30h	30h	33h	30h	30h	30h	30h	34h
Character	0	0	0	0	3	0	0	0	0	4

■ Response (Callback)

In the period when the command can be accepted

Hexadecimal	02h	56h	58h	58h	3Ah	44h	41h	4Eh	49h	31h
Character		V	X	X	:	D	A	N	I	1
Hexadecimal	3Dh	2Bh	*1	*3	*5	*7	*9	03h		
Character	=	+	*2	*4	*6	*8	*10			

Acceptability

SECURITY	STANDBY	ECO STANDBY	NO SIGNAL	SHUTTER	FREEZE	TEST PATTERN	REMOTE2	P IN P	LENS HOME
	✓		✓	✓	✓	✓	✓	✓	

3.256. Art-Net SETUP - START ADDRESS [VXX:DANI3]

Hexadecimal	02h	41h	44h	5Ah	5Ah	3Bh	56h	58h	58h	3Ah
Character		A	D	Z	Z	;	V	X	X	:
Hexadecimal	44h	41h	4Eh	49h	33h	3Dh	2Bh	*1	*3	*5
Character	D	A	N	I	3	=	+	*2	*4	*6
Hexadecimal	*7	*9	03h							
Character	*8	*10								

■ Parameters (*1,*2,*3,*4,*5,*6,*7,*8,*9,*10)

	0					501				
Hexadecimal	30h	30h	30h	30h	30h	30h	30h	35h	30h	31h
Character	0	0	0	0	0	0	0	5	0	1

■ Response (Callback)

In the period when the command can be accepted

Hexadecimal	02h	56h	58h	58h	3Ah	44h	41h	4Eh	49h	33h
Character		V	X	X	:	D	A	N	I	3
Hexadecimal	3Dh	2Bh	*1	*3	*5	*7	*9	03h		
Character	=	+	*2	*4	*6	*8	*10			

Acceptability

SECURITY	STANDBY	ECO STANDBY	NO SIGNAL	SHUTTER	FREEZE	TEST PATTERN	REMOTE2	P IN P	LENS HOME
	✓		✓	✓	✓	✓	✓	✓	

3.257. Art-Net SETUP - NET [VXX:DANI4]

Hexadecimal	02h	41h	44h	5Ah	5Ah	3Bh	56h	58h	58h	3Ah
Character		A	D	Z	Z	;	V	X	X	:
Hexadecimal	44h	41h	4Eh	49h	34h	3Dh	2Bh	*1	*3	*5
Character	D	A	N	I	4	=	+	*2	*4	*6
Hexadecimal	*7	*9	03h							
Character	*8	*10								

■ Parameters (*1,*2,*3,*4,*5,*6,*7,*8,*9,*10)

	0					127				
Hexadecimal	30h	30h	30h	30h	30h	30h	30h	31h	32h	37h
Character	0	0	0	0	0	0	0	1	2	7

■ Response (Callback)

In the period when the command can be accepted

Hexadecimal	02h	56h	58h	58h	3Ah	44h	41h	4Eh	49h	34h
Character		V	X	X	:	D	A	N	I	4
Hexadecimal	3Dh	2Bh	*1	*3	*5	*7	*9	03h		
Character	=	+	*2	*4	*6	*8	*10			

Acceptability

SECURITY	STANDBY	ECO STANDBY	NO SIGNAL	SHUTTER	FREEZE	TEST PATTERN	REMOTE2	P IN P	LENS HOME
	✓		✓	✓	✓	✓	✓	✓	

3.258. Art-Net SETUP - SUB NET [VXX:DANI5]

Hexadecimal	02h	41h	44h	5Ah	5Ah	3Bh	56h	58h	58h	3Ah
Character		A	D	Z	Z	;	V	X	X	:
Hexadecimal	44h	41h	4Eh	49h	35h	3Dh	2Bh	*1	*3	*5
Character	D	A	N	I	5	=	+	*2	*4	*6
Hexadecimal	*7	*9	03h							
Character	*8	*10								

■ Parameters (*1,*2,*3,*4,*5,*6,*7,*8,*9,*10)

	0					15				
Hexadecimal	30h	30h	30h	30h	30h	30h	30h	30h	31h	35h
Character	0	0	0	0	0	0	0	0	1	5

■ Response (Callback)

In the period when the command can be accepted

Hexadecimal	02h	56h	58h	58h	3Ah	44h	41h	4Eh	49h	35h
Character		V	X	X	:	D	A	N	I	5
Hexadecimal	3Dh	2Bh	*1	*3	*5	*7	*9	03h		
Character	=	+	*2	*4	*6	*8	*10			

Acceptability

SECURITY	STANDBY	ECO STANDBY	NO SIGNAL	SHUTTER	FREEZE	TEST PATTERN	REMOTE2	P IN P	LENS HOME
	✓		✓	✓	✓	✓	✓	✓	

3.259. Art-Net SETUP - UNIVERSE [VXX:DANI6]

Hexadecimal	02h	41h	44h	5Ah	5Ah	3Bh	56h	58h	58h	3Ah
Character		A	D	Z	Z	;	V	X	X	:
Hexadecimal	44h	41h	4Eh	49h	36h	3Dh	2Bh	*1	*3	*5
Character	D	A	N	I	6	=	+	*2	*4	*6
Hexadecimal	*7	*9	03h							
Character	*8	*10								

■ Parameters (*1,*2,*3,*4,*5,*6,*7,*8,*9,*10)

	0					15				
Hexadecimal	30h	30h	30h	30h	30h	30h	30h	30h	31h	35h
Character	0	0	0	0	0	0	0	0	1	5

■ Response (Callback)

In the period when the command can be accepted

Hexadecimal	02h	56h	58h	58h	3Ah	44h	41h	4Eh	49h	36h
Character		V	X	X	:	D	A	N	I	6
Hexadecimal	3Dh	2Bh	*1	*3	*5	*7	*9	03h		
Character	=	+	*2	*4	*6	*8	*10			

Acceptability

SECURITY	STANDBY	ECO STANDBY	NO SIGNAL	SHUTTER	FREEZE	TEST PATTERN	REMOTE2	P IN P	LENS HOME
	✓		✓	✓	✓	✓	✓	✓	

3.260. Art-Net SETUP - CHANNEL SETUP [VXX:DANI8]

Hexadecimal	02h	41h	44h	5Ah	5Ah	3Bh	56h	58h	58h	3Ah
Character		A	D	Z	Z	;	V	X	X	:
Hexadecimal	44h	41h	4Eh	49h	38h	3Dh	2Bh	*1	*3	*5
Character	D	A	N	I	8	=	+	*2	*4	*6
Hexadecimal	*7	*9	03h							
Character	*8	*10								

■ Parameters (*1,*2,*3,*4,*5,*6,*7,*8,*9,*10)

	DEFAULT					DZ870/DZ21K				
Hexadecimal	30h	30h	30h	30h	30h	30h	30h	30h	30h	31h
Character	0	0	0	0	0	0	0	0	0	1
	USER									
Hexadecimal	30h	30h	31h	30h	30h					
Character	0	0	1	0	0					

■ Response (Callback)

In the period when the command can be accepted

Hexadecimal	02h	56h	58h	58h	3Ah	44h	41h	4Eh	49h	38h
Character		V	X	X	:	D	A	N	I	8
Hexadecimal	3Dh	2Bh	*1	*3	*5	*7	*9	03h		
Character	=	+	*2	*4	*6	*8	*10			

Acceptability

SECURITY	STANDBY	ECO STANDBY	NO SIGNAL	SHUTTER	FREEZE	TEST PATTERN	REMOTE2	P IN P	LENS HOME
	✓		✓	✓	✓	✓	✓	✓	

3.261. COLOR WHEEL INDEX [VXX:CWII0]

Hexadecimal	02h	41h	44h	5Ah	5Ah	3Bh	56h	58h	58h	3Ah
Character		A	D	Z	Z	;	V	X	X	:
Hexadecimal	43h	57h	49h	49h	30h	3Dh	2Bh	*1	*3	*5
Character	C	W	I	I	0	=	+	*2	*4	*6
Hexadecimal	*7	*9	03h							
Character	*8	*10								

■ Parameters (*1,*2,*3,*4,*5,*6,*7,*8,*9,*10)

	0					511				
Hexadecimal	30h	30h	30h	30h	30h	30h	30h	35h	31h	31h
Character	0	0	0	0	0	0	0	5	1	1

■ Response (Callback)

In the period when the command can be accepted

Hexadecimal	02h	56h	58h	58h	3Ah	43h	57h	49h	49h	30h
Character		V	X	X	:	C	W	I	I	0
Hexadecimal	3Dh	2Bh	*1	*3	*5	*7	*9	03h		
Character	=	+	*2	*4	*6	*8	*10			

Acceptability

SECURITY	STANDBY	ECO STANDBY	NO SIGNAL	SHUTTER	FREEZE	TEST PATTERN	REMOTE2	P IN P	LENS HOME
			✓	✓	✓	✓	✓	✓	

3.262. QUERY POWER [QPW]

Hexadecimal	02h	41h	44h	5Ah	5Ah	3Bh	51h	50h	57h	03h
Character		A	D	Z	Z	;	Q	P	W	

■ Response (Callback)

	OFF					ON				
Hexadecimal	02h	30h	30h	30h	03h	02h	30h	30h	31h	03h
Character		0	0	0			0	0	1	

Acceptability

SECURITY	STANDBY	ECO STANDBY	NO SIGNAL	SHUTTER	FREEZE	TEST PATTERN	REMOTE2	P IN P	LENS HOME
✓	✓	✓	✓	✓	✓	✓	✓	✓	✓

3.263. QUERY FREEZE [QFZ]

Hexadecimal	02h	41h	44h	5Ah	5Ah	3Bh	51h	46h	5Ah	03h
Character		A	D	Z	Z	;	Q	F	Z	

■ Response (Callback)

	OFF			ON		
Hexadecimal	02h	30h	03h	02h	31h	03h
Character		0			1	

Acceptability

SECURITY	STANDBY	ECO STANDBY	NO SIGNAL	SHUTTER	FREEZE	TEST PATTERN	REMOTE2	P IN P	LENS HOME
✓	✓		✓	✓	✓	✓	✓	✓	✓

3.264. QUERY SHUTTER [QSH]

Hexadecimal	02h	41h	44h	5Ah	5Ah	3Bh	51h	53h	48h	03h
Character		A	D	Z	Z	;	Q	S	H	

■ Response (Callback)

	OFF			ON		
Hexadecimal	02h	30h	03h	02h	31h	03h
Character		0			1	

Acceptability

SECURITY	STANDBY	ECO STANDBY	NO SIGNAL	SHUTTER	FREEZE	TEST PATTERN	REMOTE2	P IN P	LENS HOME
✓	✓		✓	✓	✓	✓	✓	✓	✓

3.265. QUERY INPUT SELECT [QIN]

Hexadecimal	02h	41h	44h	5Ah	5Ah	3Bh	51h	49h	4Eh	03h
Character		A	D	Z	Z	;	Q	I	N	

■ Response (Callback)

RGB1

Hexadecimal	02h	52h	47h	31h	03h
Character		R	G	1	

RGB2

Hexadecimal	02h	52h	47h	32h	03h
Character		R	G	2	

VIDEO

Hexadecimal	02h	56h	49h	44h	03h
Character		V	I	D	

DVI-D

Hexadecimal	02h	44h	56h	49h	03h
Character		D	V	I	

HDMI

Hexadecimal	02h	48h	44h	31h	03h
Character		H	D	1	

SDI (DZ780,FDZ88C only)

Hexadecimal	02h	53	44	31h	03h
Character		S	D	1	

DIGITAL LINK (unconnected)

Hexadecimal	02h	44	4C	31h	03h
Character		D	L	1	

DIGITAL LINK (HDMI1)

Hexadecimal	02h	44	4C	31h	3Ah	48h	44h	31h	03h
Character		D	L	1	:	H	D	1	

DIGITAL LINK (HDMI2)

Hexadecimal	02h	44	4C	31h	3Ah	48h	44h	32h	03h
Character		D	L	1	:	H	D	2	

DIGITAL LINK (COMPUTER1)

Hexadecimal	02h	44	4C	31h	3Ah	50h	43h	31h	03h
Character		D	L	1	:	P	C	1	

DIGITAL LINK (COMPUTER2)

Hexadecimal	02h	44	4C	31h	3Ah	50h	43h	32h	03h
Character		D	L	1	:	P	C	2	

DIGITAL LINK (S-VIDEO)

Hexadecimal	02h	44	4C	31h	3Ah	53h	56h	44h	03h
Character		D	L	1	:	S	V	D	

DIGITAL LINK (VIDEO)

Hexadecimal	02h	44	4C	31h	3Ah	56h	49h	44h	03h
Character		D	L	1	:	V	I	D	

Acceptability

SECURITY	STANDBY	ECO STANDBY	NO SIGNAL	SHUTTER	FREEZE	TEST PATTERN	REMOTE2	P IN P	LENS HOME
✓	✓		✓	✓	✓	✓	✓	✓	✓

3.266. QUERY TEST PATTERN [QTS]

Hexadecimal	02h	41h	44h	5Ah	5Ah	3Bh	51h	54h	53h	03h
Character		A	D	Z	Z	;	Q	T	S	

■ Response (Callback)

In the period when the command can be accepted

Hexadecimal	02h	*1	*3	03h
Character		*2	*4	

■ Parameters (*1,*2,*3,*4)

	OFF		White		Black		Flag		Reversed Flag	
Hexadecimal	30h	30h	30h	31h	30h	32h	30h	33h	30h	34h
Character	0	0	0	1	0	2	0	3	0	4
	Window		Reversed Window		Focus (White)		Color bar (vertical)		Convergence	
Hexadecimal	30h	35h	30h	36h	31h	31h	30h	38h	31h	31h
Character	0	5	0	6	1	1	0	8	1	1
	Red		Green		Blue		Cyan		Magenta	
Hexadecimal	32h	32h	32h	33h	32h	34h	32h	38h	32h	39h
Character	2	2	2	3	2	4	2	8	2	9
	Yellow		CW INDEX		Color bar (horizontal)		16:9/4:3		Lamp (vertical)	
Hexadecimal	33h	30h	34h	31h	35h	31h	35h	39h	36h	37h
Character	3	0	4	1	5	1	5	9	6	7
	Focus (Green)		Focus (Blue)		Focus (Cyan)		Focus (Magenta)		Focus (Yellow)	
Hexadecimal	37h	31h	37h	32h	37h	33h	37h	34h	37h	35h
Character	7	1	7	2	7	3	7	4	7	5

Acceptability

SECURITY	STANDBY	ECO STANDBY	NO SIGNAL	SHUTTER	FREEZE	TEST PATTERN	REMOTE2	P IN P	LENS HOME
✓			✓	✓	✓	✓	✓	✓	✓

3.267. QUERY ON-SCREEN DISPLAY [QOS]

Hexadecimal	02h	41h	44h	5Ah	5Ah	3Bh	51h	4Fh	53h	03h
Character		A	D	Z	Z	;	Q	O	S	

■ Response (Callback)

	OFF			ON		
Hexadecimal	02h	30h	03h	02h	31h	03h
Character		0			1	

Acceptability

SECURITY	STANDBY	ECO STANDBY	NO SIGNAL	SHUTTER	FREEZE	TEST PATTERN	REMOTE2	P IN P	LENS HOME
✓			✓	✓	✓	✓	✓	✓	✓

3.268. QUERY PROJECTOR ID - ALL [QVY]

Hexadecimal	02h	41h	44h	5Ah	5Ah	3Bh	51h	56h	59h	03h
Character		A	D	Z	Z	;	Q	V	Y	

3.268. ■ Response (Callback)

	OFF			ON		
Hexadecimal	02h	30h	03h	02h	31h	03h
Character		0			1	

3.268. Acceptability

SECURITY	STANDBY	ECO STANDBY	NO SIGNAL	SHUTTER	FREEZE	TEST PATTERN	REMOTE2	P IN P	LENS HOME
✓	✓		✓	✓	✓	✓	✓	✓	✓

3.268.

3.268.

3.268.

3.268.

3.268.

3.269. QUERY SUB MEMORY USAGE STATE [QSB]

Hexadecimal	02h	41h	44h	5Ah	5Ah	3Bh	51h	53h	42h	03h
Character		A	D	Z	Z	;	Q	S	B	

■ Response (Callback)

In the period when the command can be accepted

Hexadecimal	02h	*1	*3	03h
Character		*2	*4	

Acceptability

SECURITY	STANDBY	ECO STANDBY	NO SIGNAL	SHUTTER	FREEZE	TEST PATTERN	REMOTE2	P IN P	LENS HOME
✓				✓	✓	✓	✓	✓	✓

■ Parameters (*1,*2,*3,*4)

	01		02		03		04	
Hexadecimal	30h	31h	30h	32h	30h	33h	30h	34h
Character	0	1	0	2	0	3	0	4
	93		94		95		96	
Hexadecimal	39h	33h	39h	34h	39h	35h	39h	36h
Character	9	3	9	4	9	5	9	6

■ Note:

- ER401 is returned when the sub memory is not being used.

3.270. QUERY PICTURE MODE [QPM]

Hexadecimal	02h	41h	44h	5Ah	5Ah	3Bh	51h	50h	4Dh	03h
Character		A	D	Z	Z	;	Q	P	M	

■ Response (Callback)

In the period when the command can be accepted

Hexadecimal	02h	*1	*3	*5	03h
Character		*2	*4	*6	

Acceptability

SECURITY	STANDBY	ECO STANDBY	NO SIGNAL	SHUTTER	FREEZE	TEST PATTERN	REMOTE2	P IN P	LENS HOME
✓			✓	✓	✓	✓	✓	✓	✓

■ Parameters (*1,*2,*3,*4,*5,*6)

	NATURAL			STANDARD			DYNAMIC		
Hexadecimal	4Eh	41h	54h	53h	54h	44h	44h	59h	4Eh
Character	N	A	T	S	T	D	D	Y	N
	CINEMA			GRAPHIC			EASY DICOM		
Hexadecimal	43h	49h	4Eh	47h	52h	41h	44h	49h	43h
Character	C	I	N	G	R	A	D	I	C
	REC709								
Hexadecimal	37h	30h	39h						
Character	7	0	9						

3.271. QUERY Ye MODULATE [QVX:YEMIO]

Hexadecimal	02h	41h	44h	5Ah	5Ah	3Bh	51h	56h	58h	3Ah
Character		A	D	Z	Z	;	Q	V	X	:
Hexadecimal	59h	45h	4Dh	49h	30h	03h				
Character	Y	E	M	I	0					

■ Response (Callback)

In the period when the command can be accepted

Hexadecimal	02h	59h	45h	4Dh	49h	30h	3Dh	2Bh	*1	*3
Character		Y	E	M	I	0	=	+	*2	*4
Hexadecimal	*5	*7	*9	03h						
Character	*6	*8	*10							

Acceptability

SECURITY	STANDBY	ECO STANDBY	NO SIGNAL	SHUTTER	FREEZE	TEST PATTERN	REMOTE2	P IN P	LENS HOME
✓			✓	✓	✓	✓	✓	✓	✓

■ Parameters (*1,*2,*3,*4,*5,*6,*7,*8,*9,*10)

	OFF					ON				
Hexadecimal	30h	30h	30h	30h	30h	30h	30h	30h	30h	31h
Character	0	0	0	0	0	0	0	0	0	1

3.272. QUERY DYNAMIC RGB BOOSTER [QVX:DRBI1]

Hexadecimal	02h	41h	44h	5Ah	5Ah	3Bh	51h	56h	88h	3Ah
Character		A	D	Z	Z	;	Q	V	X	:
Hexadecimal	44h	52h	42h	49h	31h	03h				
Character	D	R	B	I	1					

■ Response (Callback)

In the period when the command can be accepted

Hexadecimal	02h	44h	52h	42h	49h	31h	3Dh	2Bh
Character		D	R	B	I	1	=	+
Hexadecimal	*1	*3	*5	*7	*9	03h		
Character	*2	*4	*6	*8	*10			

Acceptability

SECURITY	STANDBY	ECO STANDBY	NO SIGNAL	SHUTTER	FREEZE	TEST PATTERN	REMOTE2	P IN P	LENS HOME
✓			✓	✓	✓	✓	✓	✓	✓

■ Parameters (*1,*2,*3,*4,*5,*6,*7,*8,*9,*10)

	OFF					1					2				
Hexadecimal	30h	30h	30h	30h	30h	30h	30h	30h	30h	31h	30h	30h	30h	30h	32h
Character	0	0	0	0	0	0	0	0	0	1	0	0	0	0	2
	7														
Hexadecimal	30h	30h	30h	30h	37h										
Character	0	0	0	0	7										

3.273. QUERY COLOR [QVC]

Hexadecimal	02h	41h	44h	5Ah	5Ah	3Bh	51h	56h	43h	03h
Character		A	D	Z	Z	;	Q	V	C	

■ Response (Callback)

In the period when the command can be accepted

Hexadecimal	02h	*1	*3	*5	03h
Character		*2	*4	*6	

Acceptability

SECURITY	STANDBY	ECO STANDBY	NO SIGNAL	SHUTTER	FREEZE	TEST PATTERN	REMOTE2	P IN P	LENS HOME
✓				✓	✓	✓	✓	✓	✓

■ Parameters (*1,*2,*3,*4,*5,*6)

	-31			-30			-29		
Hexadecimal	30h	30h	31h	30h	30h	32h	30h	30h	33h
Character	0	0	1	0	0	2	0	0	3
	+29			+30			+31		
Hexadecimal	30h	36h	31h	30h	36h	32h	30h	36h	33h
Character	0	6	1	0	6	2	0	6	3

3.274. QUERY TINT [QVT]

Hexadecimal	02h	41h	44h	5Ah	5Ah	3Bh	51h	56h	54h	03h
Character		A	D	Z	Z	;	Q	V	T	

■ Response (Callback)

In the period when the command can be accepted

Hexadecimal	02h	*1	*3	*5	03h
Character		*2	*4	*6	

Acceptability

SECURITY	STANDBY	ECO STANDBY	NO SIGNAL	SHUTTER	FREEZE	TEST PATTERN	REMOTE2	P IN P	LENS HOME
✓				✓	✓	✓	✓	✓	✓

■ Parameters (*1,*2,*3,*4,*5,*6)

	-31			-30			-29		
Hexadecimal	30h	30h	31h	30h	30h	32h	30h	30h	33h
Character	0	0	1	0	0	2	0	0	3
	+29			+30			+31		
Hexadecimal	30h	36h	31h	30h	36h	32h	30h	36h	33h
Character	0	6	1	0	6	2	0	6	3

3.275. QUERY CONTRAST [QVR]

Hexadecimal	02h	41h	44h	5Ah	5Ah	3Bh	51h	56h	52h	03h
Character		A	D	Z	Z	;	Q	V	R	

■ Response (Callback)

In the period when the command can be accepted

Hexadecimal	02h	*1	*3	*5	03h
Character		*2	*4	*6	

Acceptability

SECURITY	STANDBY	ECO STANDBY	NO SIGNAL	SHUTTER	FREEZE	TEST PATTERN	REMOTE2	P IN P	LENS HOME
✓				✓	✓	✓	✓	✓	✓

■ Parameters (*1,*2,*3,*4,*5,*6)

	-31			-30			-29		
Hexadecimal	30h	30h	31h	30h	30h	32h	30h	30h	33h
Character	0	0	1	0	0	2	0	0	3
	+29			+30			+31		
Hexadecimal	30h	36h	31h	30h	36h	32h	30h	36h	33h
Character	0	6	1	0	6	2	0	6	3

3.276. QUERY BRIGHTNESS [QVB]

Hexadecimal	02h	41h	44h	5Ah	5Ah	3Bh	51h	56h	42h	03h
Character		A	D	Z	Z	;	Q	V	B	

■ Response (Callback)

In the period when the command can be accepted

Hexadecimal	02h	*1	*3	*5	03h
Character		*2	*4	*6	

Acceptability

SECURITY	STANDBY	ECO STANDBY	NO SIGNAL	SHUTTER	FREEZE	TEST PATTERN	REMOTE2	P IN P	LENS HOME
✓				✓	✓	✓	✓	✓	✓

■ Parameters (*1,*2,*3,*4,*5,*6)

	-31			-30			-29		
Hexadecimal	30h	30h	31h	30h	30h	32h	30h	30h	33h
Character	0	0	1	0	0	2	0	0	3
	+29			+30			+31		
Hexadecimal	30h	36h	31h	30h	36h	32h	30h	36h	33h
Character	0	6	1	0	6	2	0	6	3

3.277. QUERY COLOR TEMPERATURE [QTE]

Hexadecimal	02h	41h	44h	5Ah	5Ah	3Bh	51h	54h	45h	03h
Character		A	D	Z	Z	;	Q	T	E	

■ Response (Callback)

DEFAULT

Hexadecimal	02h	31h	30h	03h
Character		1	0	

USER1

Hexadecimal	02h	34h	03h
Character		4	

USER2

Hexadecimal	02h	39h	03h
Character		9	

When the color temperature is set up

Hexadecimal	02h	*1	*3	*5	*7	03h
Character		*2	*4	*6	*8	

Acceptability

SECURITY	STANDBY	ECO STANDBY	NO SIGNAL	SHUTTER	FREEZE	TEST PATTERN	REMOTE2	P IN P	LENS HOME
✓			✓	✓	✓	✓	✓	✓	✓

■ Parameters (*1,*2,*3,*4,*5,*6,*7,*8)

	3200K				3300K			
Hexadecimal	33h	32h	30h	30h	33h	33h	30h	30h
Character	3	2	0	0	3	3	0	0
	9200K				9300K			
Hexadecimal	39h	32h	30h	30h	39h	33h	30h	30h
Character	9	2	0	0	9	3	0	0

3.278. QUERY WHITE BALANCE LOW - RED [QOR]

Hexadecimal	02h	41h	44h	5Ah	5Ah	3Bh	51h	4Fh	52h	03h
Character		A	D	Z	Z	;	Q	O	R	

■ Response (Callback)

In the period when the command can be accepted

Hexadecimal	02h	*1	*3	*5	03h
Character		*2	*4	*6	

Acceptability

SECURITY	STANDBY	ECO STANDBY	NO SIGNAL	SHUTTER	FREEZE	TEST PATTERN	REMOTE2	P IN P	LENS HOME
✓			✓	✓	✓	✓	✓	✓	✓

■ Parameters (*1,*2,*3,*4,*5,*6)

	-127			-126			-125		
Hexadecimal	30h	30h	31h	30h	30h	32h	30h	30h	33h
Character	0	0	1	0	0	2	0	0	3
	124			125			126		
Hexadecimal	32h	35h	33h	32h	35h	34h	32h	35h	35h
Character	2	5	3	2	5	4	2	5	5

3.279. QUERY WHITE BALANCE LOW - GREEN [QOG]

Hexadecimal	02h	41h	44h	5Ah	5Ah	3Bh	51h	4Fh	47h	03h
Character		A	D	Z	Z	;	Q	O	G	

■ Response (Callback)

In the period when the command can be accepted

Hexadecimal	02h	*1	*3	*5	03h
Character		*2	*4	*6	

Acceptability

SECURITY	STANDBY	ECO STANDBY	NO SIGNAL	SHUTTER	FREEZE	TEST PATTERN	REMOTE2	P IN P	LENS HOME
✓			✓	✓	✓	✓	✓	✓	✓

■ Parameters (*1,*2,*3,*4,*5,*6)

	-127			-126			-125		
Hexadecimal	30h	30h	31h	30h	30h	32h	30h	30h	33h
Character	0	0	1	0	0	2	0	0	3
	124			125			126		
Hexadecimal	32h	35h	33h	32h	35h	34h	32h	35h	35h
Character	2	5	3	2	5	4	2	5	5

3.280. QUERY WHITE BALANCE LOW - BLUE [QOB]

Hexadecimal	02h	41h	44h	5Ah	5Ah	3Bh	51h	4Fh	42h	03h
Character		A	D	Z	Z	;	Q	O	B	

■ Response (Callback)

In the period when the command can be accepted

Hexadecimal	02h	*1	*3	*5	03h
Character		*2	*4	*6	

Acceptability

SECURITY	STANDBY	ECO STANDBY	NO SIGNAL	SHUTTER	FREEZE	TEST PATTERN	REMOTE2	P IN P	LENS HOME
✓			✓	✓	✓	✓	✓	✓	✓

■ Parameters (*1,*2,*3,*4,*5,*6)

	-127			-126			-125		
Hexadecimal	30h	30h	31h	30h	30h	32h	30h	30h	33h
Character	0	0	1	0	0	2	0	0	3
	124			125			126		
Hexadecimal	32h	35h	33h	32h	35h	34h	32h	35h	35h
Character	2	5	3	2	5	4	2	5	5

3.281. QUERY WHITE BALANCE HIGH - RED [QHR]

Hexadecimal	02h	41h	44h	5Ah	5Ah	3Bh	51h	48h	52h	03h
Character		A	D	Z	Z	;	Q	H	R	

■ Response (Callback)

In the period when the command can be accepted

Hexadecimal	02h	*1	*3	*5	03h
Character		*2	*4	*6	

Acceptability

SECURITY	STANDBY	ECO STANDBY	NO SIGNAL	SHUTTER	FREEZE	TEST PATTERN	REMOTE2	P IN P	LENS HOME
✓			✓	✓	✓	✓	✓	✓	✓

■ Parameters (*1,*2,*3,*4,*5,*6)

	0			1			2		
Hexadecimal	30h	30h	30h	30h	30h	31h	30h	30h	32h
Character	0	0	0	0	0	1	0	0	2
	253			254			255		
Hexadecimal	32h	35h	33h	32h	35h	34h	32h	35h	35h
Character	2	5	3	2	5	4	2	5	5

3.282. QUERY WHITE BALANCE HIGH - GREEN [QHJ]

Hexadecimal	02h	41h	44h	5Ah	5Ah	3Bh	51h	48h	47h	03h
Character		A	D	Z	Z	;	Q	H	G	

■ Response (Callback)

In the period when the command can be accepted

Hexadecimal	02h	*1	*3	*5	03h
Character		*2	*4	*6	

Acceptability

SECURITY	STANDBY	ECO STANDBY	NO SIGNAL	SHUTTER	FREEZE	TEST PATTERN	REMOTE2	P IN P	LENS HOME
✓			✓	✓	✓	✓	✓	✓	✓

■ Parameters (*1,*2,*3,*4,*5,*6)

	0			1			2		
Hexadecimal	30h	30h	30h	30h	30h	31h	30h	30h	32h
Character	0	0	0	0	0	1	0	0	2
	253			254			255		
Hexadecimal	32h	35h	33h	32h	35h	34h	32h	35h	35h
Character	2	5	3	2	5	4	2	5	5

3.283. QUERY WHITE BALANCE HIGH - BLUE [QHB]

Hexadecimal	02h	41h	44h	5Ah	5Ah	3Bh	51h	48h	42h	03h
Character		A	D	Z	Z	;	Q	H	B	

■ Response (Callback)

In the period when the command can be accepted

Hexadecimal	02h	*1	*3	*5	03h
Character		*2	*4	*6	

Acceptability

SECURITY	STANDBY	ECO STANDBY	NO SIGNAL	SHUTTER	FREEZE	TEST PATTERN	REMOTE2	P IN P	LENS HOME
✓			✓	✓	✓	✓	✓	✓	✓

■ Parameters (*1,*2,*3,*4,*5,*6)

	0			1			2		
Hexadecimal	30h	30h	30h	30h	30h	31h	30h	30h	32h
Character	0	0	0	0	0	1	0	0	2
	253			254			255		
Hexadecimal	32h	35h	33h	32h	35h	34h	32h	35h	35h
Character	2	5	3	2	5	4	2	5	5

3.284. QUERY NAME - COLOR TEMPERATURE USER1 [QVX:NCGS1]

Hexadecimal	02h	41h	44h	5Ah	5Ah	3Bh	51h	56h	58h	3Ah
Character		A	D	Z	Z	;	Q	V	X	:
Hexadecimal	4Eh	43h	47h	53h	31h	03h				
Character	N	C	G	S	1					

■ Response (Callback)

In the period when the command can be accepted

Hexadecimal	02h	4Eh	43h	47h	53h	31h	3Dh	*1	*3	*5
Character		N	C	G	S	1	=	*2	*4	*6
Hexadecimal	*7	*9	*11	*13	*15	17	*19	*21	*23	*25
Character	*8	*10	*12	*14	*16	*18	*20	*22	*24	*26
Hexadecimal	*27	*29	03h							
Character	*28	*30								

Acceptability

SECURITY	STANDBY	ECO STANDBY	NO SIGNAL	SHUTTER	FREEZE	TEST PATTERN	REMOTE2	P IN P	LENS HOME
✓			✓	✓		✓	✓	✓	

■ Parameters (*1,*2,...,*29,*30)

Example : COLORTEMP1

	COLORTEMP1									
Hexadecimal	43h	4Fh	4Ch	4Fh	52h	54h	45h	4Dh	50h	31h
Character	C	O	L	O	R	T	E	M	P	1

■ Note:

· Responds with a undefined length name.

3.285. QUERY NAME - COLOR TEMPERATURE USER2 [QVX:NCGS3]

Hexadecimal	02h	41h	44h	5Ah	5Ah	3Bh	51h	56h	58h	3Ah
Character		A	D	Z	Z	;	Q	V	X	:
Hexadecimal	4Eh	43h	47h	53h	33h	03h				
Character	N	C	G	S	3					

■ Response (Callback)

In the period when the command can be accepted

Hexadecimal	02h	4Eh	43h	47h	53h	33h	3Dh	*1	*3	*5
Character		N	C	G	S	3	=	*2	*4	*6
Hexadecimal	*7	*9	*11	*13	*15	17	*19	*21	*23	*25
Character	*8	*10	*12	*14	*16	*18	*20	*22	*24	*26
Hexadecimal	*27	*29	03h							
Character	*28	*30								

Acceptability

SECURITY	STANDBY	ECO STANDBY	NO SIGNAL	SHUTTER	FREEZE	TEST PATTERN	REMOTE2	P IN P	LENS HOME
✓			✓	✓		✓	✓	✓	

■ Parameters (*1,*2,...,*29,*30)

Example : COLORTEMP2

	COLORTEMP2									
Hexadecimal	43h	4Fh	4Ch	4Fh	52h	54h	45h	4Dh	50h	32h
Character	C	O	L	O	R	T	E	M	P	2

■ Note:

· Responds with a undefined length name.

3.286. QUERY WHITE GAIN [QWH]

Hexadecimal	02h	41h	44h	5Ah	5Ah	3Bh	51h	57h	48h	03h
Character		A	D	Z	Z	;	Q	W	H	

■ Response (Callback)

In the period when the command can be accepted

Hexadecimal	02h	*1	*3	*5	03h
Character		*2	*4	*6	

Acceptability

SECURITY	STANDBY	ECO STANDBY	NO SIGNAL	SHUTTER	FREEZE	TEST PATTERN	REMOTE2	P IN P	LENS HOME
✓			✓	✓	✓	✓	✓	✓	✓

■ Parameters (*1,*2,*3,*4,*5,*6)

	0		1		9		10	
Hexadecimal	30h	30h	30h	31h	30h	39h	31h	30h
Character	0	0	0	1	0	9	1	0

3.287. QUERY GAMMA [QGA]

Hexadecimal	02h	41h	44h	5Ah	5Ah	3Bh	51h	47h	42h	03h
Character		A	D	Z	Z	;	Q	G	A	

■ Response (Callback)

In the period when the command can be accepted

Hexadecimal	02h	*1	*3	*5	03h
Character		*2	*4	*6	

Acceptability

SECURITY	STANDBY	ECO STANDBY	NO SIGNAL	SHUTTER	FREEZE	TEST PATTERN	REMOTE2	P IN P	LENS HOME
✓			✓	✓	✓	✓	✓	✓	✓

■ Parameters (*1,*2,*3,*4,*5,*6)

	1.8			2.0			2.2		
Hexadecimal	31h	2Eh	38h	32h	2Eh	30h	32h	2Eh	32h
Character	1	.	8	2	.	0	2	.	2

3.288. QUERY SYSTEM DAYLIGHT VIEW [QVX:DLV10]

Hexadecimal	02h	41h	44h	5Ah	5Ah	3Bh	51h	56h	88h	3Ah
Character		A	D	Z	Z	;	Q	V	X	:
Hexadecimal	44h	4Ch	56h	49h	30h	03h				
Character	D	L	V	I	0					

■ Response (Callback)

In the period when the command can be accepted

Hexadecimal	02h	44h	4Ch	56h	49h	30h	3Dh	2Bh
Character		D	L	V	I	0	=	+
Hexadecimal	*1	*3	*5	*7	*9	03h		
Character	*2	*4	*6	*8	*10			

Acceptability

SECURITY	STANDBY	ECO STANDBY	NO SIGNAL	SHUTTER	FREEZE	TEST PATTERN	REMOTE2	P IN P	LENS HOME
✓			✓	✓	✓	✓	✓	✓	✓

■ Parameters (*1,*2,*3,*4,*5,*6,*7,*8,*9,*10)

	OFF					1					2				
Hexadecimal	30h	30h	30h	30h	30h	30h	30h	30h	30h	31h	30h	30h	30h	30h	32h
Character	0	0	0	0	0	0	0	0	0	1	0	0	0	0	2
	3														
Hexadecimal	30h	30h	30h	30h	33h										
Character	0	0	0	0	3										

3.289. QUERY SHARPNESS [QVS]

Hexadecimal	02h	41h	44h	5Ah	5Ah	3Bh	51h	56h	53h	03h
Character		A	D	Z	Z	;	Q	V	S	

■ Response (Callback)

In the period when the command can be accepted

Hexadecimal	02h	*1	*3	*5	03h
Character		*2	*4	*6	

Acceptability

SECURITY	STANDBY	ECO STANDBY	NO SIGNAL	SHUTTER	FREEZE	TEST PATTERN	REMOTE2	P IN P	LENS HOME
✓				✓	✓	✓	✓	✓	✓

■ Parameters (*1,*2,*3,*4,*5,*6)

	0			1			2		
Hexadecimal	30h	30h	30h	30h	30h	31h	30h	30h	32h
Character	0	0	0	0	0	1	0	0	2
	13			14			15		
Hexadecimal	30h	31h	33h	30h	31h	34h	30h	31h	35h
Character	0	1	3	0	1	4	0	1	5

3.290. QUERY NOISE REDUCTION [QNS]

Hexadecimal	02h	41h	44h	5Ah	5Ah	3Bh	51h	4Eh	53h	03h
Character		A	D	Z	Z	;	Q	N	S	

■ Response (Callback)

In the period when the command can be accepted

Hexadecimal	02h	*1	03h
Character		*2	

Acceptability

SECURITY	STANDBY	ECO STANDBY	NO SIGNAL	SHUTTER	FREEZE	TEST PATTERN	REMOTE2	P IN P	LENS HOME
✓				✓	✓	✓	✓	✓	✓

■ Parameters (*1,*2)

	OFF	1	2	3
Hexadecimal	30h	31h	32h	33h
Character	0	1	2	3

3.291. QUERY AI [QAI]

Hexadecimal	02h	41h	44h	5Ah	5Ah	3Bh	51h	41h	49h	03h
Character		A	D	Z	Z	;	Q	A	I	

■ Response (Callback)

In the period when the command can be accepted

Hexadecimal	02h	*1	03h
Character		*2	

Acceptability

SECURITY	STANDBY	ECO STANDBY	NO SIGNAL	SHUTTER	FREEZE	TEST PATTERN	REMOTE2	P IN P	LENS HOME
✓			✓	✓	✓	✓	✓	✓	✓

■ Parameters (*1,*2)

	OFF	ON
Hexadecimal	30h	31h
Character	0	1

3.292. SYSTEM SELECTOR (VIDEO / Y/C) [QSG]

Hexadecimal	02h	41h	44h	5Ah	5Ah	3Bh	51h	53h	47h	03h
Character		A	D	Z	Z	;	Q	S	G	

■ Response (Callback)

In the period when the command can be accepted

Hexadecimal	02h	*1	*3	*5	03h
Character		*2	*4	*6	

Acceptability

SECURITY	STANDBY	ECO STANDBY	NO SIGNAL	SHUTTER	FREEZE	TEST PATTERN	REMOTE2	P IN P	LENS HOME
✓			✓	✓	✓	✓	✓	✓	✓

■ Parameters (*1,*2,*3,*4,*5,*6)

	AUTO			NTSC					
Hexadecimal	41h	54h	31h	4Eh	54h	53h			
Character	A	T	1	N	T	S			
	NTSC4.43			PAL			PAL-M		
Hexadecimal	4Eh	34h	34h	50h	41h	4Ch	50h	41h	4Dh
Character	N	4	4	P	A	L	P	A	M
	PAL-N			SECAM			PAL60		
Hexadecimal	50h	41h	4Eh	53h	45h	43h	50h	36h	30h
Character	P	A	N	S	E	C	P	6	0

3.293. SYSTEM SELECTOR (RGB/DVI-D/HDMI/DIGITAL LINK) [QRF]

Hexadecimal	02h	41h	44h	5Ah	5Ah	3Bh	51h	52h	46h	03h
Character		A	D	Z	Z	;	Q	R	F	

■ Response (Callback)

	VGA60			YPBPR/YCBCR			AUTO			480pRGB		
Hexadecimal	02h	30h	03h	02h	31h	03h	02h	32h	03h	02h	33h	03h
Character		0			1			2			3	

Acceptability

SECURITY	STANDBY	ECO STANDBY	NO SIGNAL	SHUTTER	FREEZE	TEST PATTERN	REMOTE2	P IN P	LENS HOME
✓				✓	✓	✓	✓	✓	✓

3.294. SYSTEM SELECTOR (SDI) [QSD]

Hexadecimal	02h	41h	44h	5Ah	5Ah	3Bh	51h	53h	44h	03h
Character		A	D	Z	Z	;	Q	S	D	

■ Response (Callback)

SDI (Only for DZ780,FDZ88C)

	AUTO			480i YCBCR			576i YCBCR					
Hexadecimal	02h	30h	03h	02h	31h	03h	02h	33h	03h			
Character		0			1			3				
	1080/60i YPBPR			1035/60i YPBPR			720/60p YPBPR					
Hexadecimal	02h	34h	03h	02h	35h	03h	02h	36h	03h			
Character		4			5			6				
	1080/24p YPBPR			1080/50i YPBPR			1080/30p YPBPR					
Hexadecimal	02h	37h	03h	02h	38h	03h	02h	39h	03h			
Character		7			8			9				
	1080/25p			1080/24sF			720/50p					
Hexadecimal	02h	31h	30h	03h	02h	31h	31h	03h	02h	31h	32h	03h
Character		1	0			1	1			1	2	
	1080/50p YPBPR			1080/60p YPBPR			1080/24p RGB					
Hexadecimal	02h	31h	35h	03h	02h	31h	36h	03h	02h	32h	31h	03h
Character		1	5			1	6			2	1	
	1080/24sF RGB			1080/25p RGB			1080/30p RGB					
Hexadecimal	02h	32h	32h	03h	02h	32h	33h	03h	02h	32h	34h	03h
Character		2	2			2	3			2	4	
	1080/50i RGB			1080/60i RGB								
Hexadecimal	02h	32h	35h	03h	02h	32h	36h	03h				
Character		2	5			2	6					

Acceptability

SECURITY	STANDBY	ECO STANDBY	NO SIGNAL	SHUTTER	FREEZE	TEST PATTERN	REMOTE2	P IN P	LENS HOME
✓			✓	✓	✓	✓	✓	✓	✓

3.295. QUERY SHIFT - HORIZONTAL [QTH]

Hexadecimal	02h	41h	44h	5Ah	5Ah	3Bh	51h	54h	48h	03h
Character		A	D	Z	Z	;	Q	T	H	

■ Response (Callback)

In the period when the command can be accepted

Hexadecimal	02h	*1	*3	*5	*7	03h
Character		*2	*4	*6	*8	

Acceptability

SECURITY	STANDBY	ECO STANDBY	NO SIGNAL	SHUTTER	FREEZE	TEST PATTERN	REMOTE2	P IN P	LENS HOME
✓				✓	✓	✓	✓	✓	✓

■ Parameters (*1,*2,*3,*4,*5,*6,*7,*8)

	0				1				2			
Hexadecimal	30h	30h	30h	30h	30h	30h	30h	31h	30h	30h	30h	32h
Character	0	0	0	0	0	0	0	1	0	0	0	2
	4093				4094				4095			
Hexadecimal	34h	30h	39h	33h	34h	30h	39h	34h	34h	30h	39h	35h
Character	4	0	9	3	4	0	9	4	4	0	9	5

3.296. QUERY SHIFT - VERTICAL [QTV]

Hexadecimal	02h	41h	44h	5Ah	5Ah	3Bh	51h	54h	56h	03h
Character		A	D	Z	Z	;	Q	T	V	

■ Response (Callback)

In the period when the command can be accepted

Hexadecimal	02h	*1	*3	*5	*7	03h
Character		*2	*4	*6	*8	

Acceptability

SECURITY	STANDBY	ECO STANDBY	NO SIGNAL	SHUTTER	FREEZE	TEST PATTERN	REMOTE2	P IN P	LENS HOME
✓				✓	✓	✓	✓	✓	✓

■ Parameters (*1,*2,*3,*4,*5,*6,*7,*8)

	0				1				2			
Hexadecimal	30h	30h	30h	30h	30h	30h	30h	31h	30h	30h	30h	32h
Character	0	0	0	0	0	0	0	1	0	0	0	2
	4093				4094				4095			
Hexadecimal	34h	30h	39h	33h	34h	30h	39h	34h	34h	30h	39h	35h
Character	4	0	9	3	4	0	9	4	4	0	9	5

3.297. QUERY ASPECT [QSE]

Hexadecimal	02h	41h	44h	5Ah	5Ah	3Bh	51h	53h	45h	03h
Character		A	D	Z	Z	;	Q	S	E	

■ Response (Callback)

In the period when the command can be accepted

Hexadecimal	02h	*1	*3	03h
Character		*2	*4	

Acceptability

SECURITY	STANDBY	ECO STANDBY	NO SIGNAL	SHUTTER	FREEZE	TEST PATTERN	REMOTE2	P IN P	LENS HOME
✓				✓	✓	✓	✓	✓	✓

■ Parameters (*1,*2,*3,*4)

· Input terminal : VIDEO/RGB1(Y/C), Input signal: NTSC

	VIDAUTO		4:3		16:9		THROUGH		HV FIT		
Hexadecimal	30h		31h		32h		35h		36h		
Character	0		1		2		5		6		
	H FIT		V FIT								
Hexadecimal	39h		31h		30h						
Character	9		1		0						

· Input terminal / signal : RGB1(RGB/YpbPr)/RGB2(480i,480p)

	AUTO		4:3		16:9		THROUGH		HV FIT		
Hexadecimal	30h		31h		32h		35h		36h		
Character	0		1		2		5		6		
	H FIT		V FIT								
Hexadecimal	39h		31h		30h						
Character	9		1		0						

· Input terminal / signal : Other than those above

	DEFAULT		4:3		16:9		THROUGH		HV FIT		
Hexadecimal	30h		31h		32h		35h		36h		
Character	0		1		2		5		6		
	H FIT		V FIT								
Hexadecimal	39h		31h		30h						
Character	9		1		0						

3.298. QUERY ZOOM - HORIZONTAL [QZH]

Hexadecimal	02h	41h	44h	5Ah	5Ah	3Bh	51h	5Ah	48h	03h
Character		A	D	Z	Z	;	Q	Z	H	

■ Response (Callback)

In the period when the command can be accepted

Hexadecimal	02h	*1	*3	*5	03h
Character		*2	*4	*6	

Acceptability

SECURITY	STANDBY	ECO STANDBY	NO SIGNAL	SHUTTER	FREEZE	TEST PATTERN	REMOTE2	P IN P	LENS HOME
✓				✓	✓		✓	✓	✓

■ Parameters (*1,*2,*3,*4,*5,*6)

	50			51			52		
Hexadecimal	30h	35h	30h	30h	35h	31h	30h	35h	32h
Character	0	5	0	0	5	1	0	5	2
	997			998			999		
Hexadecimal	39h	39h	37h	39h	39h	38h	39h	39h	39h
Character	9	9	7	9	9	8	9	9	9

3.299. QUERY ZOOM - VERTICAL [QZV]

Hexadecimal	02h	41h	44h	5Ah	5Ah	3Bh	51h	5Ah	56h	03h
Character		A	D	Z	Z	;	Q	Z	V	

■ Response (Callback)

In the period when the command can be accepted

Hexadecimal	02h	*1	*3	*5	03h
Character		*2	*4	*6	

Acceptability

SECURITY	STANDBY	ECO STANDBY	NO SIGNAL	SHUTTER	FREEZE	TEST PATTERN	REMOTE2	P IN P	LENS HOME
✓				✓	✓		✓	✓	✓

■ Parameters (*1,*2,*3,*4,*5,*6)

	50			51			52		
Hexadecimal	30h	35h	30h	30h	35h	31h	30h	35h	32h
Character	0	5	0	0	5	1	0	5	2
	997			998			999		
Hexadecimal	39h	39h	37h	39h	39h	38h	39h	39h	39h
Character	9	9	7	9	9	8	9	9	9

3.300. QUERY ZOOM HORIZONTAL / VERTICAL [QZO]

Hexadecimal	02h	41h	44h	5Ah	5Ah	3Bh	51h	5Ah	4Fh	03h
Character		A	D	Z	Z	;	Q	Z	O	

■ Response (Callback)

In the period when the command can be accepted

Hexadecimal	02h	*1	*3	*5	03h
Character		*2	*4	*6	

Acceptability

SECURITY	STANDBY	ECO STANDBY	NO SIGNAL	SHUTTER	FREEZE	TEST PATTERN	REMOTE2	P IN P	LENS HOME
✓				✓	✓		✓	✓	✓

■ Parameters (*1,*2,*3,*4,*5,*6)

	50			51			52		
Hexadecimal	30h	35h	30h	30h	35h	31h	30h	35h	32h
Character	0	5	0	0	5	1	0	5	2
	997			998			999		
Hexadecimal	39h	39h	37h	39h	39h	38h	39h	39h	39h
Character	9	9	7	9	9	8	9	9	9

3.301. QUERY ZOOM INTERLOCKED [QZS]

Hexadecimal	02h	41h	44h	5Ah	5Ah	3Bh	51h	5Ah	53h	03h
Character		A	D	Z	Z	;	Q	Z	S	

■ Response (Callback)

In the period when the command can be accepted

Hexadecimal	02h	*1	03h
Character		*2	

Acceptability

SECURITY	STANDBY	ECO STANDBY	NO SIGNAL	SHUTTER	FREEZE	TEST PATTERN	REMOTE2	P IN P	LENS HOME
✓				✓	✓		✓	✓	✓

■ Parameters (*1,*2)

		OFF	ON
Hexadecimal		30h	31h
Character		0	1

3.302. QUERY ZOOM MODE [QZT]

Hexadecimal	02h	41h	44h	5Ah	5Ah	3Bh	51h	5Ah	54h	03h
Character		A	D	Z	Z	;	Q	Z	T	

■ Response (Callback)

In the period when the command can be accepted

Hexadecimal	02h	*1	03h
Character		*2	

Acceptability

SECURITY	STANDBY	ECO STANDBY	NO SIGNAL	SHUTTER	FREEZE	TEST PATTERN	REMOTE2	P IN P	LENS HOME
✓				✓	✓	✓	✓	✓	✓

■ Parameters (*1,*2)

		INTERNAL	FULL
Hexadecimal		30h	31h
Character		0	1

■ Note:

· It is only effective for DEFAULT setting of ASPECT.

3.303. QUERY CLOCK PHASE [QCP]

Hexadecimal	02h	41h	44h	5Ah	5Ah	3Bh	51h	43h	50h	03h
Character		A	D	Z	Z	;	Q	C	P	

■ Response (Callback)

In the period when the command can be accepted

Hexadecimal	02h	*1	*3	*5	03h
Character		*2	*4	*6	

Acceptability

SECURITY	STANDBY	ECO STANDBY	NO SIGNAL	SHUTTER	FREEZE	TEST PATTERN	REMOTE2	P IN P	LENS HOME
✓				✓	✓	✓	✓	✓	✓

■ Parameters (*1,*2,*3,*4,*5,*6)

		0			1			2		
Hexadecimal	30h	30h	30h	30h	30h	31h	30h	30h	32h	
Character	0	0	0	0	0	1	0	0	2	
		61			62			63		
Hexadecimal	30h	36h	31h	30h	36h	32h	30h	36h	33h	
Character	0	6	1	0	6	2	0	6	3	

■ Note:

· Enabled by RGB1 or RGB2 inputs.

3.304. QUERY GEOMETRY [QVX:GMMI0]

Hexadecimal	02h	41h	44h	5Ah	5Ah	3Bh	51h	56h	58h	3Ah
Character		A	D	Z	Z	;	Q	V	X	:
Hexadecimal	47h	4Dh	4Dh	49h	30h	03h				
Character	G	M	M	I	0					

■ Response (Callback)

In the period when the command can be accepted

Hexadecimal	02h	47h	4Dh	4Dh	49h	30h	3Dh	2Bh	*1	*3
Character		G	M	M	I	0	=	+	*2	*4
Hexadecimal	*5	*7	*9	03h						
Character	*6	*8	*10							

Acceptability

SECURITY	STANDBY	ECO STANDBY	NO SIGNAL	SHUTTER	FREEZE	TEST PATTERN	REMOTE2	P IN P	LENS HOME
✓	✓		✓	✓	✓	✓	✓	✓	✓

■ Parameters (*1,*2,*3,*4,*5,*6,*7,*8,*9,*10)

		OFF					KEystone				
Hexadecimal	30h	30h	30h	30h	30h	30h	30h	30h	30h	30h	31h
Character	0	0	0	0	0	0	0	0	0	0	1
		CURVED					PC-1				
Hexadecimal	30h	30h	30h	30h	32h	30h	30h	30h	30h	33h	
Character	0	0	0	0	2	0	0	0	0	3	
		PC-2					PC-3				
Hexadecimal	30h	30h	30h	30h	34h	30h	30h	30h	30h	35h	
Character	0	0	0	0	4	0	0	0	0	5	
		CORNER CORRECTION									
Hexadecimal	30h	30h	30h	31h	30h						
Character	0	0	0	1	0						

- Note:
 - PC-1, PC-2, PC-3 : Only for DZ780(FDZ88C)

3.305. QUERY GEOMETRY : KEYSTONE - LENS THROW RATIO [QVX:GMKS0]

Hexadecimal	02h	41h	44h	5Ah	5Ah	3Bh	51h	56h	58h	3Ah
Character		A	D	Z	Z	;	Q	V	X	:
Hexadecimal	47h	4Dh	4Bh	53h	30h	03h				
Character	G	M	K	S	0					

■ Response (Callback)

In the period when the command can be accepted

Hexadecimal	02h	47h	4Dh	4Bh	53h	30h	3Dh	2Bh	*1	*3
Character		G	M	K	S	0	=	+	*2	*4
Hexadecimal	*5	*7	03h							
Character	*6	*8								

Acceptability

SECURITY	STANDBY	ECO STANDBY	NO SIGNAL	SHUTTER	FREEZE	TEST PATTERN	REMOTE2	P IN P	LENS HOME
✓	✓		✓	✓	✓	✓	✓	✓	✓

■ Parameters (*1,*2,*3,*4,*5,*6,*7,*8)

	0.7					0.8				
Hexadecimal	30h	30h	2Eh	37h		30h	30h	2Eh	38h	
Character	0	0	.	7		0	0	.	8	
	16.4					16.5				
Hexadecimal	31h	36h	2Eh	35h		31h	36h	2Eh	35h	
Character	1	6	.	4		1	6	.	5	

■ Note:

- It is only effective for DZ780(FDZ88C), other models return ER401.

3.306. QUERY GEOMETRY : KEYSTONE - VERTICAL BALANCE [QVX:GMKI4]

Hexadecimal	02h	41h	44h	5Ah	5Ah	3Bh	51h	56h	58h	3Ah
Character		A	D	Z	Z	;	Q	V	X	:
Hexadecimal	47h	4Dh	4Bh	49h	34h	03h				
Character	G	M	K	I	4					

■ Response (Callback)

In the period when the command can be accepted

Hexadecimal	02h	47h	4Dh	4Bh	49h	34h	3Dh	*1	*3	*5
Character		G	M	K	I	4	=	*2	*4	*6
Hexadecimal	*7	*9	*11	03h						
Character	*8	*10	*12							

Acceptability

SECURITY	STANDBY	ECO STANDBY	NO SIGNAL	SHUTTER	FREEZE	TEST PATTERN	REMOTE2	P IN P	LENS HOME
✓	✓		✓	✓	✓	✓	✓	✓	✓

■ Parameters (*1,*2,*3,*4,*5,*6,*7,*8,*9,*10,*11,*12)

	-60						-59					
Hexadecimal	2Dh	30h	30h	30h	36h	30h	2Dh	30h	30h	30h	35h	39h
Character	—	0	0	0	6	0	—	0	0	0	5	9
	+59						+60					
Hexadecimal	2Bh	30h	30h	30h	35h	39h	2Bh	30h	30h	30h	36h	30h
Character	+	0	0	0	5	9	+	0	0	0	6	0

■ Note:

- It is only effective for DZ780(FDZ88C), other models return ER401.

3.307. QUERY GEOMETRY : KEYSTONE - HORIZONTAL BALANCE [QVX:GMKI7]

Hexadecimal	02h	41h	44h	5Ah	5Ah	3Bh	51h	56h	58h	3Ah
Character		A	D	Z	Z	;	Q	V	X	:
Hexadecimal	47h	4Dh	4Bh	49h	37h	03h				
Character	G	M	K	I	7					

■ Response (Callback)

In the period when the command can be accepted

Hexadecimal	02h	47h	4Dh	4Bh	49h	37h	3Dh	*1	*3	*5
Character		G	M	K	I	7	=	*2	*4	*6
Hexadecimal	*7	*9	*11	03h						
Character	*8	*10	*12							

Acceptability

SECURITY	STANDBY	ECO STANDBY	NO SIGNAL	SHUTTER	FREEZE	TEST PATTERN	REMOTE2	P IN P	LENS HOME
✓	✓		✓	✓	✓	✓	✓	✓	✓

■ Parameters (*1,*2,*3,*4,*5,*6,*7,*8,*9,*10,*11,*12)

	-30						-29					
Hexadecimal	2Dh	30h	30h	30h	33h	30h	2Dh	30h	30h	30h	32h	39h
Character	—	0	0	0	3	0	—	0	0	0	2	9
	+29						+30					
Hexadecimal	2Bh	30h	30h	30h	32h	39h	2Bh	30h	30h	30h	33h	30h
Character	+	0	0	0	2	9	+	0	0	0	3	0

■ Note:

· It is only effective for DZ780(FDZ88C), other models return ER401.

3.308. QUERY GEOMETRY : KEYSTONE - VERTICAL KEYSTONE [QVX:GMKS8]

Hexadecimal	02h	41h	44h	5Ah	5Ah	3Bh	51h	56h	58h	3Ah
Character		A	D	Z	Z	;	Q	V	X	:
Hexadecimal	47h	4Dh	4Bh	53h	38h	03h				
Character	G	M	K	S	8					

■ Response (Callback)

In the period when the command can be accepted

Hexadecimal	02h	47h	4Dh	4Bh	53h	38h	3Dh	*1	*3	*5
Character		G	M	K	S	8	=	*2	*4	*6
Hexadecimal	*7	*9	03h							
Character	*8	*10								

Acceptability

SECURITY	STANDBY	ECO STANDBY	NO SIGNAL	SHUTTER	FREEZE	TEST PATTERN	REMOTE2	P IN P	LENS HOME
✓	✓		✓	✓	✓	✓	✓	✓	✓

■ Parameters (*1,*2,*3,*4,*5,*6,*7,*8,*9,*10)

	-40.0					-38.8				
Hexadecimal	2Dh	34h	30h	2Eh	30h	2Dh	33h	38h	2Eh	38h
Character	-	4	0	.	0	-	3	8	.	8
	-9.8					+00.0				
Hexadecimal	2Dh	30h	39h	2Eh	38h	2Bh	30h	30h	2Eh	30h
Character	-	0	9	.	8	+	0	0	.	0
	+38.8					+40.0				
Hexadecimal	2Bh	33h	38h	2Eh	38h	2Bh	34h	30h	2Eh	30h
Character	+	3	8	.	8	+	4	0	.	0

■ Note:

· It is only effective for DZ780(FDZ88C), other models return ER401.

3.309. QUERY GEOMETRY : KEYSTONE - HORIZONTAL KEYSTONE [QVX:GMKS9]

Hexadecimal	02h	41h	44h	5Ah	5Ah	3Bh	51h	56h	58h	3Ah
Character		A	D	Z	Z	;	Q	V	X	:
Hexadecimal	47h	4Dh	4Bh	53h	39h	03h				
Character	G	M	K	S	9					

■ Response (Callback)

In the period when the command can be accepted

Hexadecimal	02h	47h	4Dh	4Bh	53h	39h	3Dh	*1	*3	*5
Character		G	M	K	S	9	=	*2	*4	*6
Hexadecimal	*7	*9	03h							
Character	*8	*10								

Acceptability

SECURITY	STANDBY	ECO STANDBY	NO SIGNAL	SHUTTER	FREEZE	TEST PATTERN	REMOTE2	P IN P	LENS HOME
✓	✓		✓	✓	✓	✓	✓	✓	✓

■ Parameters (*1,*2,*3,*4,*5,*6,*7,*8,*9,*10)

	-15.0					-14.8				
Hexadecimal	2Dh	31h	35h	2Eh	30h	2Dh	31h	34h	2Eh	38h
Character	-	1	5	.	0	-	1	4	.	8
	-9.8					+0.0				
Hexadecimal	2Dh	30h	39h	2Eh	38h	2Bh	30h	30h	2Eh	30h
Character	-	0	9	.	8	+	0	0	.	0
	+14.8					+15.0				
Hexadecimal	2Bh	31h	34h	2Eh	38h	2Bh	31H	35H	2Eh	30h
Character	+	1	4	.	8	+	1	5	.	0

■ Note:

· It is only effective for DZ780(FDZ88C), other models return ER401.

3.310. QUERY GEOMETRY : CURVED - LENS THROW RATIO [QVX:GMCS0]

Hexadecimal	02h	41h	44h	5Ah	5Ah	3Bh	51h	56h	58h	3Ah
Character		A	D	Z	Z	;	Q	V	X	:
Hexadecimal	47h	4Dh	43h	53h	30h	03h				
Character	G	M	C	S	0					

■ Response (Callback)

In the period when the command can be accepted

Hexadecimal	02h	47h	4Dh	43h	53h	30h	3Dh	2Bh	*1	*3
Character		G	M	C	S	0	=	+	*2	*4
Hexadecimal	*5	*7	03h							
Character	*6	*8								

Acceptability

SECURITY	STANDBY	ECO STANDBY	NO SIGNAL	SHUTTER	FREEZE	TEST PATTERN	REMOTE2	P IN P	LENS HOME
✓	✓		✓	✓	✓	✓	✓	✓	✓

■ Parameters (*1,*2,*3,*4,*5,*6,*7,*8,)

	0.7					0.8				
Hexadecimal	30h	30h	2Eh	37h	30h	30h	2Eh	38h		
Character	0	0	.	7	0	0	.	8		
	16.4					16.5				
Hexadecimal	31h	36h	2Eh	34h	31h	36h	2Eh	35h		
Character	1	6	.	4	1	6	.	5		

■ Note:

· It is only effective for DZ780(FDZ88C), other models return ER401.

3.311. QUERY GEOMETRY : CURVED - VERTICAL ARC [QVX:GMCI3]

Hexadecimal	02h	41h	44h	5Ah	5Ah	3Bh	51h	56h	58h	3Ah
Character		A	D	Z	Z	;	Q	V	X	:
Hexadecimal	47h	4Dh	43h	49h	33h	03h				
Character	G	M	C	I	3					

■ Response (Callback)

In the period when the command can be accepted

Hexadecimal	02h	47h	4Dh	43h	49h	33h	3Dh	*1	*3	*5
Character		G	M	C	I	3	=	*2	*4	*6
Hexadecimal	*7	*9	*11	03h						
Character	*8	*10	*12							

Acceptability

SECURITY	STANDBY	ECO STANDBY	NO SIGNAL	SHUTTER	FREEZE	TEST PATTERN	REMOTE2	P IN P	LENS HOME
✓	✓		✓	✓	✓	✓	✓	✓	✓

■ Parameters (*1,*2,*3,*4,*5,*6,*7,*8,*9,*10,*11,*12)

	-50						-49					
Hexadecimal	2Dh	30h	30h	30h	35h	30h	2Dh	30h	30h	30h	34h	39h
Character	—	0	0	0	5	0	—	0	0	0	4	9
	+49						+50					
Hexadecimal	2Bh	30h	30h	30h	34h	39h	2Bh	30h	30h	30h	35h	30h
Character	+	0	0	0	4	9	+	0	0	0	5	0

■ Note:

· It is only effective for DZ780(FDZ88C), other models return ER401.

3.312. QUERY GEOMETRY : CURVED - HORIZONTAL ARC [QVX:GMCI7]

Hexadecimal	02h	41h	44h	5Ah	5Ah	3Bh	51h	56h	58h	3Ah
Character		A	D	Z	Z	;	Q	V	X	:
Hexadecimal	47h	4Dh	43h	49h	37h	03h				
Character	G	M	C	I	7					

■ Response (Callback)

In the period when the command can be accepted

Hexadecimal	02h	47h	4Dh	43h	49h	37h	3Dh	*1	*3	*5
Character		G	M	C	I	7	=	*2	*4	*6
Hexadecimal	*7	*9	*11	03h						
Character	*8	*10	*12							

Acceptability

SECURITY	STANDBY	ECO STANDBY	NO SIGNAL	SHUTTER	FREEZE	TEST PATTERN	REMOTE2	P IN P	LENS HOME
✓	✓		✓	✓	✓	✓	✓	✓	✓

■ Parameters (*1,*2,*3,*4,*5,*6,*7,*8,*9,*10,*11,*12)

	-50						-49					
Hexadecimal	2Dh	30h	30h	30h	35h	30h	2Dh	30h	30h	30h	34h	39h
Character	—	0	0	0	5	0	—	0	0	0	4	9
	+49						+50					
Hexadecimal	2Bh	30h	30h	30h	34h	39h	2Bh	30h	30h	30h	35h	30h
Character	+	0	0	0	4	9	+	0	0	0	5	0

■ Note:

· It is only effective for DZ780(FDZ88C), other models return ER401.

3.313. QUERY GEOMETRY : CURVED - VERTICAL BALANCE [QVX:GMCI2]

Hexadecimal	02h	41h	44h	5Ah	5Ah	3Bh	51h	56h	58h	3Ah
Character		A	D	Z	Z	;	Q	V	X	:
Hexadecimal	47h	4Dh	43h	49h	32h	03h				
Character	G	M	C	I	2					

■ Response (Callback)

In the period when the command can be accepted

Hexadecimal	02h	47h	4Dh	43h	49h	32h	3Dh	*1	*3	*5
Character		G	M	C	I	2	=	*2	*4	*6
Hexadecimal	*7	*9	*11	03h						
Character	*8	*10	*12							

Acceptability

SECURITY	STANDBY	ECO STANDBY	NO SIGNAL	SHUTTER	FREEZE	TEST PATTERN	REMOTE2	P IN P	LENS HOME
✓	✓		✓	✓	✓	✓	✓	✓	✓

■ Parameters (*1,*2,*3,*4,*5,*6,*7,*8,*9,*10,*11,*12)

	-60						-59					
Hexadecimal	2Dh	30h	30h	30h	36h	30h	2Dh	30h	30h	30h	35h	39h
Character	—	0	0	0	6	0	—	0	0	0	5	9
	+59						+60					
Hexadecimal	2Bh	30h	30h	30h	35h	39h	2Bh	30h	30h	30h	36h	30h
Character	+	0	0	0	5	9	+	0	0	0	6	0

■ Note:

· It is only effective for DZ780(FDZ88C), other models return ER401.

3.314. QUERY GEOMETRY : CURVED - HORIZONTAL BALANCE [QVX:GMCI6]

Hexadecimal	02h	41h	44h	5Ah	5Ah	3Bh	51h	56h	58h	3Ah
Character		A	D	Z	Z	;	Q	V	X	:
Hexadecimal	47h	4Dh	43h	49h	36h	03h				
Character	G	M	C	I	6					

■ Response (Callback)

In the period when the command can be accepted

Hexadecimal	02h	47h	4Dh	43h	49h	36h	3Dh	*1	*3	*5
Character		G	M	C	I	6	=	*2	*4	*6
Hexadecimal	*7	*9	*11	03h						
Character	*8	*10	*12							

Acceptability

SECURITY	STANDBY	ECO STANDBY	NO SIGNAL	SHUTTER	FREEZE	TEST PATTERN	REMOTE2	P IN P	LENS HOME
✓	✓		✓	✓	✓	✓	✓	✓	✓

■ Parameters (*1,*2,*3,*4,*5,*6,*7,*8,*9,*10,*11,*12)

	-30						-29					
Hexadecimal	2Dh	30h	30h	30h	33h	30h	2Dh	30h	30h	30h	32h	39h
Character	—	0	0	0	3	0	—	0	0	0	2	9
	+29						+30					
Hexadecimal	2Bh	30h	30h	30h	32h	39h	2Bh	30h	30h	30h	33h	30h
Character	+	0	0	0	2	9	+	0	0	0	3	0

■ Note:

· It is only effective for DZ780(FDZ88C), other models return ER401.

3.315. QUERY GEOMETRY : CURVED - VERTICAL KEYSTONE [QVX:GMCS8]

Hexadecimal	02h	41h	44h	5Ah	5Ah	3Bh	51h	56h	58h	3Ah
Character		A	D	Z	Z	;	Q	V	X	:
Hexadecimal	47h	4Dh	43h	53h	38h	03h				
Character	G	M	C	S	8					

■ Response (Callback)

In the period when the command can be accepted

Hexadecimal	02h	47h	4Dh	43h	53h	38h	3Dh	*1	*3	*5
Character		G	M	C	S	8	=	*2	*4	*6
Hexadecimal	*7	*9	03h							
Character	*8	*10								

Acceptability

SECURITY	STANDBY	ECO STANDBY	NO SIGNAL	SHUTTER	FREEZE	TEST PATTERN	REMOTE2	P IN P	LENS HOME
✓	✓		✓	✓	✓	✓	✓	✓	✓

■ Parameters (*1,*2,*3,*4,*5,*6,*7,*8,*9,*10)

	-40.0					-38.8				
Hexadecimal	2Dh	34h	30h	2Eh	30h	2Dh	33h	38h	2Eh	38h
Character	-	4	0	.	0	-	3	8	.	8
	-9.8					+00.0				
Hexadecimal	2Dh	30h	39h	2Eh	38h	2Bh	30h	30h	2Eh	30h
Character	-	0	9	.	8	+	0	0	.	0
	+38.8					+40.0				
Hexadecimal	2Bh	33h	38h	2Eh	38h	2Bh	34h	30h	2Eh	30h
Character	+	3	8	.	8	+	4	0	.	0

■ Note:

· It is only effective for DZ780(FDZ88C), other models return ER401.

3.316. QUERY GEOMETRY : CURVED - VERTICAL KEYSTONE [QVX:GMCS9]

Hexadecimal	02h	41h	44h	5Ah	5Ah	3Bh	51h	56h	58h	3Ah
Character		A	D	Z	Z	;	Q	V	X	:
Hexadecimal	47h	4Dh	43h	53h	39h	03h				
Character	G	M	C	S	9					

■ Response (Callback)

In the period when the command can be accepted

Hexadecimal	02h	47h	4Dh	43h	53h	39h	3Dh	*1	*3	*5
Character		G	M	C	S	9	=	*2	*4	*6
Hexadecimal	*7	*9	03h							
Character	*8	*10								

Acceptability

SECURITY	STANDBY	ECO STANDBY	NO SIGNAL	SHUTTER	FREEZE	TEST PATTERN	REMOTE2	P IN P	LENS HOME
✓	✓		✓	✓	✓	✓	✓	✓	✓

■ Parameters (*1,*2,*3,*4,*5,*6,*7,*8,*9,*10)

	-15.0					-14.8				
Hexadecimal	2Dh	31h	35h	2Eh	30h	2Dh	31h	34h	2Eh	38h
Character	-	1	5	.	0	-	1	4	.	8
	-9.8					+0.0				
Hexadecimal	2Dh	30h	39h	2Eh	38h	2Bh	30h	30h	2Eh	30h
Character	-	0	9	.	8	+	0	0	.	0
	+14.8					+15.0				
Hexadecimal	2Bh	31h	34h	2Eh	38h	2Bh	31h	35h	2Eh	30h
Character	+	1	4	.	8	+	1	5	.	0

■ Note:

· It is only effective for DZ780(FDZ88C), other models return ER401.

3.317. QUERY GEOMETRY : CURVED - MAINTAIN ASPECT RATIO [QVX:GMCIA]

Hexadecimal	02h	41h	44h	5Ah	5Ah	3Bh	51h	56h	58h	3Ah
Character		A	D	Z	Z	;	Q	V	X	:
Hexadecimal	47h	4Dh	43h	49h	41h	3Dh	2Bh	*1	*3	*5
Character	G	M	C	l	A	=	+	*2	*4	*6
Hexadecimal	*7	*9	03h							
Character	*8	*10								

■ Response (Callback)

In the period when the command can be accepted

Hexadecimal	02h	47h	4Dh	43h	49h	41h	3Dh	*1	*3	*5
Character		G	M	C	l	A	=	*2	*4	*6
Hexadecimal	*7	*9	03h							
Character	*8	*10								

Acceptability

SECURITY	STANDBY	ECO STANDBY	NO SIGNAL	SHUTTER	FREEZE	TEST PATTERN	REMOTE2	P IN P	LENS HOME
✓	✓		✓	✓	✓	✓	✓	✓	✓

■ Parameters (*1,*2,*3,*4,*5,*6,*7,*8,*9,*10)

	OFF					ON				
Hexadecimal	30h	30h	30h	30h	30h	30h	30h	30h	30h	31h
Character	0	0	0	0	0	0	0	0	0	1

■ Note:

· It is only effective for DZ780(FDZ88C), other models return ER401.

3.318. QUERY GEOMETRY : CORNER CORRECTION - UPPER LEFT - VERTICAL [QVX:GMFI1]

Hexadecimal	02h	41h	44h	5Ah	5Ah	3Bh	51h	56h	58h	3Ah
Character		A	D	Z	Z	;	Q	V	X	:
Hexadecimal	47h	4Dh	46h	49h	31h	3Dh	*1	*3	*5	*7
Character	G	M	F	l	1	=	*2	*4	*6	*8
Hexadecimal	*9	*11	03h							
Character	*10	*12								

■ Response (Callback)

In the period when the command can be accepted

Hexadecimal	02h	47h	4Dh	46h	49h	31h	3Dh	*1	*3	*5
Character		G	M	F	l	1	=	*2	*4	*6
Hexadecimal	*7	*9	*11	03h						
Character	*8	*10	*12							

Acceptability

SECURITY	STANDBY	ECO STANDBY	NO SIGNAL	SHUTTER	FREEZE	TEST PATTERN	REMOTE2	P IN P	LENS HOME
✓	✓		✓	✓	✓	✓	✓	✓	✓

■ Parameters (*1,*2,*3,*4,*5,*6,*7,*8,*9,*10,*11,*12)

	+0						+300					
Hexadecimal	2Bh	30h	30h	30h	30h	30h	2Bh	30h	30h	33h	30h	30h
Character	+	0	0	0	0	0	+	0	0	3	0	0

■ Note:

· It is only effective for DZ780(FDZ88C), other models return ER401.

3.319. QUERY GEOMETRY : CORNER CORRECTION - UPPER RIGHT - VERTICAL [QVX:GMFI2]

Hexadecimal	02h	41h	44h	5Ah	5Ah	3Bh	51h	56h	58h	3Ah
Character		A	D	Z	Z	;	Q	V	X	:
Hexadecimal	47h	4Dh	46h	49h	32h	3Dh	*1	*3	*5	*7
Character	G	M	F	l	2	=	*2	*4	*6	*8
Hexadecimal	*9	*11	03h							
Character	*10	*12								

■ Response (Callback)

In the period when the command can be accepted

Hexadecimal	02h	47h	4Dh	46h	49h	32h	3Dh	*1	*3	*5
Character		G	M	F	l	2	=	*2	*4	*6
Hexadecimal	*7	*9	*11	03h						
Character	*8	*10	*12							

Acceptability

SECURITY	STANDBY	ECO STANDBY	NO SIGNAL	SHUTTER	FREEZE	TEST PATTERN	REMOTE2	P IN P	LENS HOME
✓	✓		✓	✓	✓	✓	✓	✓	✓

■ Parameters (*1,*2,*3,*4,*5,*6,*7,*8,*9,*10,*11,*12)

	+0						+300					
Hexadecimal	2Bh	30h	30h	30h	30h	30h	2Bh	30h	30h	33h	30h	30h
Character	+	0	0	0	0	0	+	0	0	3	0	0

■ Note:

· It is only effective for DZ780(FDZ88C), other models return ER401.

3.320. QUERY GEOMETRY : CORNER CORRECTION - LOWER LEFT - VERTICAL [QVX:GMFI3]

Hexadecimal	02h	41h	44h	5Ah	5Ah	3Bh	51h	56h	58h	3Ah
Character		A	D	Z	Z	;	Q	V	X	:
Hexadecimal	47h	4Dh	46h	49h	33h	3Dh	*1	*3	*5	*7
Character	G	M	F	l	3	=	*2	*4	*6	*8
Hexadecimal	*9	*11	03h							
Character	*10	*12								

■ Response (Callback)

In the period when the command can be accepted

Hexadecimal	02h	47h	4Dh	46h	49h	33h	3Dh	*1	*3	*5
Character		G	M	F	l	3	=	*2	*4	*6
Hexadecimal	*7	*9	*11	03h						
Character	*8	*10	*12							

Acceptability

SECURITY	STANDBY	ECO STANDBY	NO SIGNAL	SHUTTER	FREEZE	TEST PATTERN	REMOTE2	P IN P	LENS HOME
✓	✓		✓	✓	✓	✓	✓	✓	✓

■ Parameters (*1,*2,*3,*4,*5,*6,*7,*8,*9,*10,*11,*12)

	-300						+0					
Hexadecimal	2Dh	30h	30h	30h	30h	30h	2Bh	30h	30h	30h	30h	30h
Character	—	0	0	0	0	0	+	0	0	0	0	0

■ Note:

· It is only effective for DZ780(FDZ88C), other models return ER401.

3.321. QUERY GEOMETRY : CORNER CORRECTION - LOWER RIGHT - VERTICAL [QVX:GMFI4]

Hexadecimal	02h	41h	44h	5Ah	5Ah	3Bh	51h	56h	58h	3Ah
Character		A	D	Z	Z	;	Q	V	X	:
Hexadecimal	47h	4Dh	46h	49h	34h	3Dh	*1	*3	*5	*7
Character	G	M	F	l	4	=	*2	*4	*6	*8
Hexadecimal	*9	*11	03h							
Character	*10	*12								

■ Response (Callback)

In the period when the command can be accepted

Hexadecimal	02h	47h	4Dh	46h	49h	34h	3Dh	*1	*3	*5
Character		G	M	F	l	4	=	*2	*4	*6
Hexadecimal	*7	*9	*11	03h						
Character	*8	*10	*12							

Acceptability

SECURITY	STANDBY	ECO STANDBY	NO SIGNAL	SHUTTER	FREEZE	TEST PATTERN	REMOTE2	P IN P	LENS HOME
✓	✓		✓	✓	✓	✓	✓	✓	✓

■ Parameters (*1,*2,*3,*4,*5,*6,*7,*8,*9,*10,*11,*12)

	-300						+0					
Hexadecimal	2Dh	30h	30h	33h	30h	30h	2Bh	30h	30h	30h	30h	30h
Character	—	0	0	3	0	0	+	0	0	0	0	0

■ Note:

· It is only effective for DZ780(FDZ88C), other models return ER401.

3.322. QUERY GEOMETRY : CORNER CORRECTION - LINEARITY - VERTICAL [QVX:GMFI5]

Hexadecimal	02h	41h	44h	5Ah	5Ah	3Bh	51h	56h	58h	3Ah
Character		A	D	Z	Z	;	Q	V	X	:
Hexadecimal	47h	4Dh	46h	49h	35h	3Dh	*1	*3	*5	*7
Character	G	M	F	l	5	=	*2	*4	*6	*8
Hexadecimal	*9	*11	03h							
Character	*10	*12								

■ Response (Callback)

In the period when the command can be accepted

Hexadecimal	02h	47h	4Dh	46h	49h	35h	3Dh	*1	*3	*5
Character		G	M	F	l	5	=	*2	*4	*6
Hexadecimal	*7	*9	*11	03h						
Character	*8	*10	*12							

Acceptability

SECURITY	STANDBY	ECO STANDBY	NO SIGNAL	SHUTTER	FREEZE	TEST PATTERN	REMOTE2	P IN P	LENS HOME
✓	✓		✓	✓	✓	✓	✓	✓	✓

■ Parameters (*1,*2,*3,*4,*5,*6,*7,*8,*9,*10,*11,*12)

	-127						+128					
Hexadecimal	2Dh	30h	30h	31h	32h	37h	2Bh	30h	30h	31h	32h	37h
Character	—	0	0	1	2	7	+	0	0	1	2	7

■ Note:

· It is only effective for DZ780(FDZ88C), other models return ER401.

3.323. QUERY GEOMETRY : CORNER CORRECTION - UPPER LEFT - HORIZONTAL [QVX:GMFI6]

Hexadecimal	02h	41h	44h	5Ah	5Ah	3Bh	51h	56h	58h	3Ah
Character		A	D	Z	Z	;	Q	V	X	:
Hexadecimal	47h	4Dh	46h	49h	36h	3Dh	*1	*3	*5	*7
Character	G	M	F	l	6	=	*2	*4	*6	*8
Hexadecimal	*9	*11	03h							
Character	*10	*12								

■ Response (Callback)

In the period when the command can be accepted

Hexadecimal	02h	47h	4Dh	46h	49h	36h	3Dh	*1	*3	*5
Character		G	M	F	l	6	=	*2	*4	*6
Hexadecimal	*7	*9	*11	03h						
Character	*8	*10	*12							

Acceptability

SECURITY	STANDBY	ECO STANDBY	NO SIGNAL	SHUTTER	FREEZE	TEST PATTERN	REMOTE2	P IN P	LENS HOME
✓	✓		✓	✓	✓	✓	✓	✓	✓

■ Parameters (*1,*2,*3,*4,*5,*6,*7,*8,*9,*10,*11,*12)

	+0						+480					
Hexadecimal	2Bh	30h	30h	30h	30h	30h	2Bh	30h	30h	34h	38h	30h
Character	+	0	0	0	0	0	+	0	0	4	8	0

■ Note:

· It is only effective for DZ780(FDZ88C), other models return ER401.

3.324. QUERY GEOMETRY : CORNER CORRECTION - UPPER RIGHT - HORIZONTAL [QVX:GMF17]

Hexadecimal	02h	41h	44h	5Ah	5Ah	3Bh	51h	56h	58h	3Ah
Character		A	D	Z	Z	;	Q	V	X	:
Hexadecimal	47h	4Dh	46h	49h	37h	3Dh	*1	*3	*5	*7
Character	G	M	F	l	7	=	*2	*4	*6	*8
Hexadecimal	*9	*11	03h							
Character	*10	*12								

■ Response (Callback)

In the period when the command can be accepted

Hexadecimal	02h	47h	4Dh	46h	49h	37h	3Dh	*1	*3	*5
Character		G	M	F	l	7	=	*2	*4	*6
Hexadecimal	*7	*9	*11	03h						
Character	*8	*10	*12							

Acceptability

SECURITY	STANDBY	ECO STANDBY	NO SIGNAL	SHUTTER	FREEZE	TEST PATTERN	REMOTE2	P IN P	LENS HOME
✓	✓		✓	✓	✓	✓	✓	✓	✓

■ Parameters (*1,*2,*3,*4,*5,*6,*7,*8,*9,*10,*11,*12)

	-480						+0					
Hexadecimal	2Dh	30h	30h	34h	38h	30h	2Bh	30h	30h	30h	30h	30h
Character	—	0	0	4	8	0	+	0	0	0	0	0

■ Note:

· It is only effective for DZ780(FDZ88C), other models return ER401.

3.325. QUERY GEOMETRY : CORNER CORRECTION - LOWER LEFT - HORIZONTAL [QVX:GMF18]

Hexadecimal	02h	41h	44h	5Ah	5Ah	3Bh	51h	56h	58h	3Ah
Character		A	D	Z	Z	;	Q	V	X	:
Hexadecimal	47h	4Dh	46h	49h	38h	3Dh	*1	*3	*5	*7
Character	G	M	F	l	8	=	*2	*4	*6	*8
Hexadecimal	*9	*11	03h							
Character	*10	*12								

■ Response (Callback)

In the period when the command can be accepted

Hexadecimal	02h	47h	4Dh	46h	49h	38h	3Dh	*1	*3	*5
Character		G	M	F	l	8	=	*2	*4	*6
Hexadecimal	*7	*9	*11	03h						
Character	*8	*10	*12							

Acceptability

SECURITY	STANDBY	ECO STANDBY	NO SIGNAL	SHUTTER	FREEZE	TEST PATTERN	REMOTE2	P IN P	LENS HOME
✓	✓		✓	✓	✓	✓	✓	✓	✓

■ Parameters (*1,*2,*3,*4,*5,*6,*7,*8,*9,*10,*11,*12)

	+0						+480					
Hexadecimal	2Bh	30h	30h	30h	30h	30h	2Bh	30h	30h	34h	38h	30h
Character	+	0	0	0	0	0	+	0	0	4	8	0

■ Note:

· It is only effective for DZ780(FDZ88C), other models return ER401.

3.326. QUERY GEOMETRY : CORNER CORRECTION - LOWER RIGHT - HORIZONTAL [QVX:GMF19]

Hexadecimal	02h	41h	44h	5Ah	5Ah	3Bh	51h	56h	58h	3Ah
Character		A	D	Z	Z	;	Q	V	X	:
Hexadecimal	47h	4Dh	46h	49h	31h	3Dh	*1	*3	*5	*7
Character	G	M	F	l	9	=	*2	*4	*6	*8
Hexadecimal	*9	*11	03h							
Character	*10	*12								

■ Response (Callback)

In the period when the command can be accepted

Hexadecimal	02h	47h	4Dh	46h	49h	39h	3Dh	*1	*3	*5
Character		G	M	F	l	9	=	*2	*4	*6
Hexadecimal	*7	*9	*11	03h						
Character	*8	*10	*12							

Acceptability

SECURITY	STANDBY	ECO STANDBY	NO SIGNAL	SHUTTER	FREEZE	TEST PATTERN	REMOTE2	P IN P	LENS HOME
✓	✓		✓	✓	✓	✓	✓	✓	✓

■ Parameters (*1,*2,*3,*4,*5,*6,*7,*8,*9,*10,*11,*12)

	-480						+0					
Hexadecimal	2Dh	30h	30h	34h	38h	30h	2Bh	30h	30h	30h	30h	30h
Character	—	0	0	4	8	0	+	0	0	0	0	0

■ Note:

· It is only effective for DZ780(FDZ88C), other models return ER401.

3.327. QUERY GEOMETRY : CORNER CORRECTION - LINEARITY - HORIZONTAL [QVX:GMFIA]

Hexadecimal	02h	41h	44h	5Ah	5Ah	3Bh	51h	56h	58h	3Ah
Character		A	D	Z	Z	;	Q	V	X	:
Hexadecimal	47h	4Dh	46h	49h	41h	3Dh	*1	*3	*5	*7
Character	G	M	F	I	A	=	*2	*4	*6	*8
Hexadecimal	*9	*11	03h							
Character	*10	*12								

■ Response (Callback)

In the period when the command can be accepted

Hexadecimal	02h	47h	4Dh	46h	49h	41h	3Dh	*1	*3	*5
Character		G	M	F	I	A	=	*2	*4	*6
Hexadecimal	*7	*9	*11	03h						
Character	*8	*10	*12							

Acceptability

SECURITY	STANDBY	ECO STANDBY	NO SIGNAL	SHUTTER	FREEZE	TEST PATTERN	REMOTE2	P IN P	LENS HOME
✓	✓		✓	✓	✓	✓	✓	✓	✓

■ Parameters (*1,*2,*3,*4,*5,*6,*7,*8,*9,*10,*11,*12)

	-127						+127					
Hexadecimal	2Dh	30h	30h	31h	32h	37h	2Bh	30h	30h	31h	32h	37h
Character	—	0	0	1	2	7	+	0	0	1	2	7

■ Note:

· It is only effective for DZ780(FDZ88C), other models return ER401.

3.328. QUERY DIGITAL CINEMA REALITY [QPD]

Hexadecimal	02h	41h	44h	5Ah	5Ah	3Bh	51h	50h	44h	03h
Character		A	D	Z	Z	;	Q	P	D	

■ Response (Callback)

In the period when the command can be accepted

Hexadecimal	02h	*1	03h
Character		*2	

Acceptability

SECURITY	STANDBY	ECO STANDBY	NO SIGNAL	SHUTTER	FREEZE	TEST PATTERN	REMOTE2	P IN P	LENS HOME
✓			✓	✓	✓	✓	✓	✓	✓

■ Parameters (*1,*2)

	AUTO	OFF	30p/25p FIXED
Hexadecimal	30h	31h	32h
Character	0	1	2

3.329. QUERY BLANKING - UPPER [QLU]

Hexadecimal	02h	41h	44h	5Ah	5Ah	3Bh	51h	4Ch	55h	03h
Character		A	D	Z	Z	;	Q	L	U	

■ Response (Callback)

In the period when the command can be accepted

Hexadecimal	02h	*1	*3	*5	03h
Character		*2	*4	*6	

Acceptability

SECURITY	STANDBY	ECO STANDBY	NO SIGNAL	SHUTTER	FREEZE	TEST PATTERN	REMOTE2	P IN P	LENS HOME
✓				✓	✓	✓	✓	✓	✓

■ Parameters (*1,*2,*3,*4,*5,*6)

	0			1			2		
Hexadecimal	30h	30h	30h	30h	30h	31h	30h	30h	32h
Character	0	0	0	0	0	1	0	0	2

DZ780(FDZ88C)

	597			598			599		
Hexadecimal	35h	39h	37h	35h	39h	38h	35h	39h	39h
Character	5	9	7	5	9	8	5	9	9

DW750(FDW85C)

	397			398			399		
Hexadecimal	33h	39h	37h	33h	39h	38h	33h	39h	39h
Character	3	9	7	3	9	8	3	9	9

DX820(FDX92C,FDG05C)

	381			382			383		
Hexadecimal	33h	38h	31h	33h	38h	32h	33h	38h	33h
Character	3	8	1	3	8	2	3	8	3

3.330. QUERY BLANKING - LOWER [QLB]

Hexadecimal	02h	41h	44h	5Ah	5Ah	3Bh	51h	4Ch	42h	03h
Character		A	D	Z	Z	;	Q	L	B	

■ Response (Callback)

In the period when the command can be accepted

Hexadecimal	02h	*1	*3	*5	03h
Character		*2	*4	*6	

Acceptability

SECURITY	STANDBY	ECO STANDBY	NO SIGNAL	SHUTTER	FREEZE	TEST PATTERN	REMOTE2	P IN P	LENS HOME
✓				✓	✓	✓	✓	✓	✓

■ Parameters (*1,*2,*3,*4,*5,*6)

	0			1			2		
Hexadecimal	30h	30h	30h	30h	30h	31h	30h	30h	32h
Character	0	0	0	0	0	1	0	0	2

DZ780(FDZ88C)

	597			598			599		
Hexadecimal	35h	39h	37h	35h	39h	38h	35h	39h	39h
Character	5	9	7	5	9	8	5	9	9

DW750(FDW85C)

	397			398			399		
Hexadecimal	33h	39h	37h	33h	39h	38h	33h	39h	39h
Character	3	9	7	3	9	8	3	9	9

DX820(FDX92C,FD605C)

	381			382			383		
Hexadecimal	33h	38h	31h	33h	38h	32h	33h	38h	33h
Character	3	8	1	3	8	2	3	8	3

3.331. QUERY BLANKING - RIGHT [QLR]

Hexadecimal	02h	41h	44h	5Ah	5Ah	3Bh	51h	4Ch	52h	03h
Character		A	D	Z	Z	;	Q	L	R	

■ Response (Callback)

In the period when the command can be accepted

Hexadecimal	02h	*1	*3	*5	03h
Character		*2	*4	*6	

Acceptability

SECURITY	STANDBY	ECO STANDBY	NO SIGNAL	SHUTTER	FREEZE	TEST PATTERN	REMOTE2	P IN P	LENS HOME
✓				✓	✓	✓	✓	✓	✓

■ Parameters (*1,*2,*3,*4,*5,*6)

	0			1			2		
Hexadecimal	30h	30h	30h	30h	30h	31h	30h	30h	32h
Character	0	0	0	0	0	1	0	0	2

DZ780(FDZ88C)

	957			958			959		
Hexadecimal	39h	35h	37h	39h	35h	38h	39h	35h	39h
Character	9	5	7	9	5	8	9	5	9

DW750(FDW85C)

	697			698			699		
Hexadecimal	36h	39h	37h	36h	39h	38h	36h	39h	39h
Character	6	9	7	6	9	8	6	9	9

DX820(FDX92C,FD605C)

	509			510			511		
Hexadecimal	35h	30h	39h	35h	31h	30h	35h	31h	31h
Character	5	0	9	5	1	0	5	1	1

3.332. QUERY BLANKING - LEFT [QLL]

Hexadecimal	02h	41h	44h	5Ah	5Ah	3Bh	51h	4Ch	4Ch	03h
Character		A	D	Z	Z	;	Q	L	L	

■ Response (Callback)

In the period when the command can be accepted

Hexadecimal	02h	*1	*3	*5	03h
Character		*2	*4	*6	

Acceptability

SECURITY	STANDBY	ECO STANDBY	NO SIGNAL	SHUTTER	FREEZE	TEST PATTERN	REMOTE2	P IN P	LENS HOME
✓				✓	✓	✓	✓	✓	✓

■ Parameters (*1,*2,*3,*4,*5,*6)

	0			1			2		
Hexadecimal	30h	30h	30h	30h	30h	31h	30h	30h	32h
Character	0	0	0	0	0	1	0	0	2
DZ780(FDZ88C)									
	957			958			959		
Hexadecimal	39h	35h	37h	39h	35h	38h	39h	35h	39h
Character	9	5	7	9	5	8	9	5	9
DW750(FDW85C)									
	697			698			699		
Hexadecimal	36h	39h	37h	36h	39h	38h	36h	39h	39h
Character	6	9	7	6	9	8	6	9	9
DX820(FDX92C,FD605C)									
	509			510			511		
Hexadecimal	35h	30h	39h	35h	31h	30h	35h	31h	31h
Character	5	0	9	5	1	0	5	1	1

3.333. QUERY CUSTOM MASKING [QVX:MSKI1]

Hexadecimal	02h	41h	44h	5Ah	5Ah	3Bh	51h	56h	58h	3Ah
Character		A	D	Z	Z	;	Q	V	X	:
Hexadecimal	4Dh	53h	4Bh	49h	31h	03h				
Character	M	S	K	I	1					

■ Response (Callback)

In the period when the command can be accepted

Hexadecimal	02h	4Dh	53h	4Bh	49h	31h	3Dh	2Bh	*1	*3
Character		M	S	K	I	1	=	+	*2	*4
Hexadecimal	*5	*7	*9	03h						
Character	*6	*8	*10							

Acceptability

SECURITY	STANDBY	ECO STANDBY	NO SIGNAL	SHUTTER	FREEZE	TEST PATTERN	REMOTE2	P IN P	LENS HOME
✓			✓	✓	✓	✓	✓	✓	✓

■ Parameters (*1,*2,*3,*4,*5,*6,*7,*8,*9,*10)

	OFF					PC-1				
Hexadecimal	30h	30h	30h	30h	30h	30h	30h	30h	30h	31h
Character	0	0	0	0	0	0	0	0	0	1
	PC-2					PC-3				
Hexadecimal	30h	30h	30h	30h	32h	30h	30h	30h	30h	33h
Character	0	0	0	0	2	0	0	0	0	3

■ Note:

· To use this function, an optional upgrade kit (activated) is required.

3.334. QUERY INPUT RESOLUTION - TOTAL DOTS [QTD]

Hexadecimal	02h	41h	44h	5Ah	5Ah	3Bh	51h	54h	44h	03h
Character		A	D	Z	Z	;	Q	T	D	

■ Response (Callback)

In the period when the command can be accepted

Hexadecimal	02h	*1	*3	*5	*7	03h
Character		*2	*4	*6	*8	

Acceptability

SECURITY	STANDBY	ECO STANDBY	NO SIGNAL	SHUTTER	FREEZE	TEST PATTERN	REMOTE2	P IN P	LENS HOME
✓				✓	✓	✓	✓	✓	✓

■ Parameters (*1,*2,*3,*4,*5,*6,*7,*8)

	330				331			
Hexadecimal	30h	33h	33h	30h	30h	33h	33h	31h
Character	0	3	3	0	0	3	3	1
	4095				4096			
Hexadecimal	34h	30h	39h	35h	34h	30h	39h	36h
Character	4	0	9	5	4	0	9	6

■ Note:

· Enabled by RGB1 or RGB2 inputs.

3.335. QUERY INPUT RESOLUTION - DISPLAY DOTS [QDD]

Hexadecimal	02h	41h	44h	5Ah	5Ah	3Bh	51h	44h	44h	03h
Character		A	D	Z	Z	;	Q	D	D	

■ Response (Callback)

In the period when the command can be accepted

Hexadecimal	02h	*1	*3	*5	*7	03h
Character		*2	*4	*6	*8	

Acceptability

SECURITY	STANDBY	ECO STANDBY	NO SIGNAL	SHUTTER	FREEZE	TEST PATTERN	REMOTE2	P IN P	LENS HOME
✓				✓	✓	✓	✓	✓	✓

■ Parameters (*1,*2,*3,*4,*5,*6,*7,*8)

	300				301			
Hexadecimal	30h	33h	30h	30h	30h	33h	30h	31h
Character	0	3	0	0	0	3	0	1
	2065				2066			
Hexadecimal	32h	30h	36h	35h	32h	30h	36h	36h
Character	2	0	6	5	2	0	6	6

■ Note:

· Enabled by RGB1 or RGB2 inputs.

3.336. QUERY INPUT RESOLUTION - TOTAL LINES [QTL]

Hexadecimal	02h	41h	44h	5Ah	5Ah	3Bh	51h	54h	4Ch	03h
Character		A	D	Z	Z	;	Q	T	L	

■ Response (Callback)

In the period when the command can be accepted

Hexadecimal	02h	*1	*3	*5	*7	03h
Character		*2	*4	*6	*8	

Acceptability

SECURITY	STANDBY	ECO STANDBY	NO SIGNAL	SHUTTER	FREEZE	TEST PATTERN	REMOTE2	P IN P	LENS HOME
✓				✓	✓	✓	✓	✓	✓

■ Parameters (*1,*2,*3,*4,*5,*6,*7,*8)

	306				307			
Hexadecimal	30h	33h	30h	36h	30h	33h	30h	37h
Character	0	3	0	6	0	3	0	7
	2046				2047			
Hexadecimal	32h	30h	34h	36h	32h	30h	34h	37h
Character	2	0	4	6	2	0	4	7

■ Note:

· Enabled by RGB1 or RGB2 inputs.

3.337. QUERY INPUT RESOLUTION - DISPLAY LINES [QDL]

Hexadecimal	02h	41h	44h	5Ah	5Ah	3Bh	51h	44h	4Ch	03h
Character		A	D	Z	Z	;	Q	D	L	

■ Response (Callback)

In the period when the command can be accepted

Hexadecimal	02h	*1	*3	*5	*7	03h
Character		*2	*4	*6	*8	

Acceptability

SECURITY	STANDBY	ECO STANDBY	NO SIGNAL	SHUTTER	FREEZE	TEST PATTERN	REMOTE2	P IN P	LENS HOME
✓				✓	✓	✓	✓	✓	✓

■ Parameters (*1,*2,*3,*4,*5,*6,*7,*8)

	300				301			
Hexadecimal	30h	33h	30h	30h	30h	33h	30h	31h
Character	0	3	0	0	0	3	0	1
	1199				1200			
Hexadecimal	31h	31h	39h	39h	31h	32h	30h	30h
Character	1	1	9	9	1	2	0	0

■ Note:

· Enabled by RGB1 or RGB2 inputs.

3.338. QUERY CLAMP POSITION [QLT]

Hexadecimal	02h	41h	44h	5Ah	5Ah	3Bh	51h	4Ch	54h	03h
Character		A	D	Z	Z	;	Q	L	T	

■ Response (Callback)

In the period when the command can be accepted

Hexadecimal	02h	*1	*3	*5	03h
Character		*2	*4	*6	

Acceptability

SECURITY	STANDBY	ECO STANDBY	NO SIGNAL	SHUTTER	FREEZE	TEST PATTERN	REMOTE2	P IN P	LENS HOME
✓			✓	✓	✓	✓	✓	✓	✓

■ Parameters (*1,*2,*3,*4,*5,*6)

	1			2		
Hexadecimal	30h	30h	31h	30h	30h	32h
Character	0	0	1	0	0	2
	254			255		
Hexadecimal	32h	35h	34h	32h	35h	35h
Character	2	5	4	2	5	5

■ Note:

· This command is available only when RGB1 or RGB2 is selected. In other case returns the ER401.

3.339. QUERY EDGE BLENDING [QVX:EDBI0]

Hexadecimal	02h	41h	44h	5Ah	5Ah	3Bh	51h	56h	58h	3Ah
Character		A	D	Z	Z	;	Q	V	X	:
Hexadecimal	45h	44h	42h	49h	30h	03h				
Character	E	D	B	l	0					

■ Response (Callback)

In the period when the command can be accepted

Hexadecimal	02h	45h	44h	42h	49h	30h	3Dh	2Bh	*1	*3
Character		E	D	B	l	0	=	+	*2	*4
Hexadecimal	*5	*7	*9	03h						
Character	*6	*8	*10							

Acceptability

SECURITY	STANDBY	ECO STANDBY	NO SIGNAL	SHUTTER	FREEZE	TEST PATTERN	REMOTE2	P IN P	LENS HOME
✓			✓	✓	✓	✓	✓	✓	✓

■ Parameters (*1,*2,*3,*4,*5,*6,*7,*8,*9,*10)

	OFF					ON					USER				
Hexadecimal	30h	30h	30h	30h	30h	30h	30h	30h	30h	31h	30h	30h	30h	30h	32h
Character	0	0	0	0	0	0	0	0	0	1	0	0	0	0	2

3.340. QUERY EDGE BLENDING - UPPER ON/OFF [QGU]

Hexadecimal	02h	41h	44h	5Ah	5Ah	3Bh	51h	47h	55h	03h
Character		A	D	Z	Z	;	Q	G	U	

■ Response (Callback)

In the period when the command can be accepted

Hexadecimal	02h	*1	03h
Character		*2	

Acceptability

SECURITY	STANDBY	ECO STANDBY	NO SIGNAL	SHUTTER	FREEZE	TEST PATTERN	REMOTE2	P IN P	LENS HOME
✓			✓	✓	✓	✓	✓	✓	✓

■ Parameters (*1,*2)

	OFF		ON	
Hexadecimal	30h		31h	
Character	0		1	

3.341. QUERY EDGE BLENDING - LOWER ON/OFF [QGB]

Hexadecimal	02h	41h	44h	5Ah	5Ah	3Bh	51h	47h	42h	03h
Character		A	D	Z	Z	;	Q	G	B	

■ Response (Callback)

In the period when the command can be accepted

Hexadecimal	02h	*1	03h
Character		*2	

Acceptability

SECURITY	STANDBY	ECO STANDBY	NO SIGNAL	SHUTTER	FREEZE	TEST PATTERN	REMOTE2	P IN P	LENS HOME
✓			✓	✓	✓	✓	✓	✓	✓

■ Parameters (*1,*2)

	OFF	ON
Hexadecimal	30h	31h
Character	0	1

3.342. QUERY EDGE BLENDING - LEFT ON/OFF [QGL]

Hexadecimal	02h	41h	44h	5Ah	5Ah	3Bh	51h	47h	4Ch	03h
Character		A	D	Z	Z	;	Q	G	L	

■ Response (Callback)

In the period when the command can be accepted

Hexadecimal	02h	*1	03h
Character		*2	

Acceptability

SECURITY	STANDBY	ECO STANDBY	NO SIGNAL	SHUTTER	FREEZE	TEST PATTERN	REMOTE2	P IN P	LENS HOME
✓			✓	✓	✓	✓	✓	✓	✓

■ Parameters (*1,*2)

	OFF	ON
Hexadecimal	30h	31h
Character	0	1

3.343. QUERY EDGE BLENDING - RIGHT ON/OFF [QGR]

Hexadecimal	02h	41h	44h	5Ah	5Ah	3Bh	51h	47h	52h	03h
Character		A	D	Z	Z	;	Q	G	R	

■ Response (Callback)

In the period when the command can be accepted

Hexadecimal	02h	*1	03h
Character		*2	

Acceptability

SECURITY	STANDBY	ECO STANDBY	NO SIGNAL	SHUTTER	FREEZE	TEST PATTERN	REMOTE2	P IN P	LENS HOME
✓			✓	✓	✓	✓	✓	✓	✓

■ Parameters (*1,*2)

	OFF	ON
Hexadecimal	30h	31h
Character	0	1

3.344. QUERY EDGE BLENDING - START - UPPER [QEU]

Hexadecimal	02h	41h	44h	5Ah	5Ah	3Bh	51h	45h	55h	03h
Character		A	D	Z	Z	;	Q	E	U	

■ Response (Callback)

In the period when the command can be accepted

Hexadecimal	02h	*1	*3	*5	*7	03h
Character		*2	*4	*6	*8	

Acceptability

SECURITY	STANDBY	ECO STANDBY	NO SIGNAL	SHUTTER	FREEZE	TEST PATTERN	REMOTE2	P IN P	LENS HOME
✓			✓	✓	✓	✓	✓	✓	✓

■ Parameters (*1,*2,*3,*4,*5,*6,*7,*8)

	0	1199			
Hexadecimal	30h	31h	31h	39h	39h
Character	0	1	1	9	9

3.345. QUERY EDGE BLENDING - START - LOWER [QEB]

Hexadecimal	02h	41h	44h	5Ah	5Ah	3Bh	51h	45h	42h	03h
Character		A	D	Z	Z	;	Q	E	B	

■ Response (Callback)

In the period when the command can be accepted

Hexadecimal	02h	*1	*3	*5	*7	03h
Character		*2	*4	*6	*8	

Acceptability

SECURITY	STANDBY	ECO STANDBY	NO SIGNAL	SHUTTER	FREEZE	TEST PATTERN	REMOTE2	P IN P	LENS HOME
✓			✓	✓	✓	✓	✓	✓	✓

■ Parameters (*1,*2,*3,*4,*5,*6,*7,*8)

	0	1199			
Hexadecimal	30h	31h	31h	39h	39h
Character	0	1	1	9	9

3.346. QUERY EDGE BLENDING - START - LEFT [QEL]

Hexadecimal	02h	41h	44h	5Ah	5Ah	3Bh	51h	45h	4Ch	03h
Character		A	D	Z	Z	;	Q	E	L	

■ Response (Callback)

In the period when the command can be accepted

Hexadecimal	02h	*1	*3	*5	*7	03h
Character		*2	*4	*6	*8	

Acceptability

SECURITY	STANDBY	ECO STANDBY	NO SIGNAL	SHUTTER	FREEZE	TEST PATTERN	REMOTE2	P IN P	LENS HOME
✓			✓	✓	✓	✓	✓	✓	✓

■ Parameters (*1,*2,*3,*4,*5,*6,*7,*8)

	0			1919			
Hexadecimal	30h			31h	39h	31h	39h
Character	0			1	9	1	9

3.347. QUERY EDGE BLENDING - START - RIGHT [QER]

Hexadecimal	02h	41h	44h	5Ah	5Ah	3Bh	51h	45h	52h	03h
Character		A	D	Z	Z	;	Q	E	R	

■ Response (Callback)

In the period when the command can be accepted

Hexadecimal	02h	*1	*3	*5	*7	03h
Character		*2	*4	*6	*8	

Acceptability

SECURITY	STANDBY	ECO STANDBY	NO SIGNAL	SHUTTER	FREEZE	TEST PATTERN	REMOTE2	P IN P	LENS HOME
✓			✓	✓	✓	✓	✓	✓	✓

■ Parameters (*1,*2,*3,*4,*5,*6,*7,*8)

	0			1919			
Hexadecimal	30h			31h	39h	31h	39h
Character	0			1	9	1	9

3.348. QUERY EDGE BLENDING - WIDTH - UPPER [QVX:EUWI0]

Hexadecimal	02h	41h	44h	5Ah	5Ah	3Bh	51h	56h	58h	3Ah
Character		A	D	Z	Z	;	Q	V	X	:
Hexadecimal	45h	55h	57h	49h	30h	03h				
Character	E	U	W	I	0					

■ Response (Callback)

In the period when the command can be accepted

Hexadecimal	02h	45h	55h	57h	49h	30h	3Dh	2Bh	*1	*3
Character		E	U	W	I	0	=	+	*2	*4
Hexadecimal	*5	*7	*9	03h						
Character	*6	*8	*10							

Acceptability

SECURITY	STANDBY	ECO STANDBY	NO SIGNAL	SHUTTER	FREEZE	TEST PATTERN	REMOTE2	P IN P	LENS HOME
✓			✓	✓	✓	✓	✓	✓	✓

■ Parameters (*1,*2,*3,*4,*5,*6,*7,*8,*9,*10)

	0					1199				
Hexadecimal	30h	30h	30h	30h	30h	30h	31h	31h	39h	39h
Character	0	0	0	0	0	0	1	1	9	9

3.349. QUERY EDGE BLENDING - WIDTH - LOWER [QVX:EBWI0]

Hexadecimal	02h	41h	44h	5Ah	5Ah	3Bh	51h	56h	58h	3Ah
Character		A	D	Z	Z	;	Q	V	X	:
Hexadecimal	45h	42h	57h	49h	30h	03h				
Character	E	B	W	I	0					

■ Response (Callback)

In the period when the command can be accepted

Hexadecimal	02h	45h	42h	57h	49h	30h	3Dh	2Bh	*1	*3
Character		E	B	W	I	0	=	+	*2	*4
Hexadecimal	*5	*7	*9	03h						
Character	*6	*8	*10							

Acceptability

SECURITY	STANDBY	ECO STANDBY	NO SIGNAL	SHUTTER	FREEZE	TEST PATTERN	REMOTE2	P IN P	LENS HOME
✓			✓	✓	✓	✓	✓	✓	✓

■ Parameters (*1,*2,*3,*4,*5,*6,*7,*8,*9,*10)

	0					1199				
Hexadecimal	30h	30h	30h	30h	30h	30h	31h	31h	39h	39h
Character	0	0	0	0	0	0	1	1	9	9

3.350. QUERY EDGE BLENDING - WIDTH - LEFT [QVX:ELWI0]

Hexadecimal	02h	41h	44h	5Ah	5Ah	3Bh	51h	56h	58h	3Ah
Character		A	D	Z	Z	;	Q	V	X	:
Hexadecimal	45h	4Ch	57h	49h	30h	03h				
Character	E	L	W	I	0					

■ Response (Callback)

In the period when the command can be accepted

Hexadecimal	02h	45h	4Ch	57h	49h	30h	3Dh	2Bh	*1	*3
Character		E	L	W	I	0	=	+	*2	*4
Hexadecimal	*5	*7	*9	03h						
Character	*6	*8	*10							

Acceptability

SECURITY	STANDBY	ECO STANDBY	NO SIGNAL	SHUTTER	FREEZE	TEST PATTERN	REMOTE2	P IN P	LENS HOME
✓			✓	✓	✓	✓	✓	✓	✓

■ Parameters (*1,*2,*3,*4,*5,*6,*7,*8,*9,*10)

	0					1919				
Hexadecimal	30h	30h	30h	30h	30h	30h	31h	39h	31h	39h
Character	0	0	0	0	0	0	1	9	1	9

3.351. QUERY EDGE BLENDING - WIDTH - RIGHT [QVX:ERWI0]

Hexadecimal	02h	41h	44h	5Ah	5Ah	3Bh	51h	56h	58h	3Ah
Character		A	D	Z	Z	;	Q	V	X	:
Hexadecimal	45h	52h	57h	49h	30h	03h				
Character	E	R	W	I	0					

■ Response (Callback)

In the period when the command can be accepted

Hexadecimal	02h	45h	52h	57h	49h	30h	3Dh	2Bh	*1	*3
Character		E	R	W	I	0	=	+	*2	*4
Hexadecimal	*5	*7	*9	03h						
Character	*6	*8	*10							

Acceptability

SECURITY	STANDBY	ECO STANDBY	NO SIGNAL	SHUTTER	FREEZE	TEST PATTERN	REMOTE2	P IN P	LENS HOME
✓			✓	✓	✓	✓	✓	✓	✓

■ Parameters (*1,*2,*3,*4,*5,*6,*7,*8,*9,*10)

	0					1919				
Hexadecimal	30h	30h	30h	30h	30h	30h	31h	39h	31h	39h
Character	0	0	0	0	0	0	1	9	1	9

3.352. QUERY EDGE BLENDING - MARKER ON/OFF [QGM]

Hexadecimal	02h	41h	44h	5Ah	5Ah	3Bh	51h	47h	4Dh	03h
Character		A	D	Z	Z	;	Q	G	M	

■ Response (Callback)

In the period when the command can be accepted

Hexadecimal	02h	*1	03h
Character		*2	

Acceptability

SECURITY	STANDBY	ECO STANDBY	NO SIGNAL	SHUTTER	FREEZE	TEST PATTERN	REMOTE2	P IN P	LENS HOME
✓			✓	✓	✓	✓	✓	✓	✓

■ Parameters (*1,*2)

	OFF	ON
Hexadecimal	30h	31h
Character	0	1

3.353. QUERY EDGE BLENDING - NON-OVERLAPPED BLACK LEVEL [QJ]

Hexadecimal	02h	41h	44h	5Ah	5Ah	3Bh	51h	4Ah	49h	03h
Character		A	D	Z	Z	;	Q	J	I	

■ Response (Callback)

In the period when the command can be accepted

Hexadecimal	02h	*1	*3	*5	2Ch	*7	*9	*11	2Ch
Character		*2	*4	*6	,	*8	*10	*12	,
Hexadecimal	*13	*15	*17	2Ch	*19	*21	*23	03h	
Character	*14	*16	*18	,	*20	*22	*24		

Acceptability

SECURITY	STANDBY	ECO STANDBY	NO SIGNAL	SHUTTER	FREEZE	TEST PATTERN	REMOTE2	P IN P	LENS HOME
✓			✓	✓	✓	✓	✓	✓	✓

■ Parameters (*1,*2,*3,*4,*5,*6) : White

	0			255		
Hexadecimal	30h	30h	30h	32h	35h	35h
Character	0	0	0	2	5	5

Parameters (*7,*8,*9,*10,*11,*12) : Red

	0			255		
Hexadecimal	30h	30h	30h	32h	35h	35h
Character	0	0	0	2	5	5

Parameters (*13,*14,*15,*16,*17,*18) : Green

	0			255		
Hexadecimal	30h	30h	30h	32h	35h	35h
Character	0	0	0	2	5	5

Parameters (*19,*20,*21,*22,*23,*24) : Blue

	0			255		
Hexadecimal	30h	30h	30h	32h	35h	35h
Character	0	0	0	2	5	5

3.354. QUERY EDGE BLENDING - NON-OVERLAPPED BLACK LEVEL - INTERLOCKED [QVX:EBII1]

Hexadecimal	02h	41h	44h	5Ah	5Ah	3Bh	51h	56h	58h	3Ah
Character		A	D	Z	Z	;	Q	V	X	:
Hexadecimal	45h	42h	42h	49h	31h	03h				
Character	E	B	B	I	1					

■ Response (Callback)

In the period when the command can be accepted

Hexadecimal	02h	45h	42h	42h	49h	31h	3Dh	2Bh	*1	*3
Character		E	B	B	I	1	=	+	*2	*4
Hexadecimal	*5	*7	*9	03h						
Character	*6	*8	*10							

Acceptability

SECURITY	STANDBY	ECO STANDBY	NO SIGNAL	SHUTTER	FREEZE	TEST PATTERN	REMOTE2	P IN P	LENS HOME
✓			✓	✓	✓	✓	✓	✓	✓

■ Parameters (*1,*2,*3,*4,*5,*6,*7,*8,*9,*10)

	OFF					ON				
Hexadecimal	30h	30h	30h	30h	30h	30h	30h	30h	30h	31h
Character	0	0	0	0	0	0	0	0	0	1

3.355. QUERY EDGE BLENDING - BLACK BORDER LEVEL [QJO]

Hexadecimal	02h	41h	44h	5Ah	5Ah	3Bh	51h	4Ah	4Fh	03h
Character		A	D	Z	Z	;	Q	J	O	

■ Response (Callback)

In the period when the command can be accepted

Hexadecimal	02h	*1	*3	*5	2Ch	*7	*9	*11	2Ch
Character		*2	*4	*6	,	*8	*10	*12	,
Hexadecimal	*13	*15	*17	2Ch	*19	*21	*23	03h	
Character	*14	*16	*18	,	*20	*22	*24		

Acceptability

SECURITY	STANDBY	ECO STANDBY	NO SIGNAL	SHUTTER	FREEZE	TEST PATTERN	REMOTE2	P IN P	LENS HOME
✓			✓	✓	✓	✓	✓	✓	✓

■ Parameters (*1,*2,*3,*4,*5,*6) : White

	0			255		
Hexadecimal	30h	30h	30h	32h	35h	35h
Character	0	0	0	2	5	5

Parameters (*7,*8,*9,*10,*11,*12) : Red

	0			255		
Hexadecimal	30h	30h	30h	32h	35h	35h
Character	0	0	0	2	5	5

Parameters (*13,*14,*15,*16,*17,*18) : Green

	0			255		
Hexadecimal	30h	30h	30h	32h	35h	35h
Character	0	0	0	2	5	5

Parameters (*19,*20,*21,*22,*23,*24) : Blue

	0			255		
Hexadecimal	30h	30h	30h	32h	35h	35h
Character	0	0	0	2	5	5

3.356. QUERY EDGE BLENDING - BLACK BORDER LEVEL - INTERLOCKED [QVX:EBII2]

Hexadecimal	02h	41h	44h	5Ah	5Ah	3Bh	51h	56h	58h	3Ah
Character		A	D	Z	Z	;	Q	V	X	:
Hexadecimal	45h	42h	42h	49h	32h	03h				
Character	E	B	B	I	2					

■ Response (Callback)

In the period when the command can be accepted

Hexadecimal	02h	45h	42h	42h	49h	32h	3Dh	2Bh	*1	*3
Character		E	B	B	I	2	=	+	*2	*4
Hexadecimal	*5	*7	*9	03h						
Character	*6	*8	*10							

Acceptability

SECURITY	STANDBY	ECO STANDBY	NO SIGNAL	SHUTTER	FREEZE	TEST PATTERN	REMOTE2	P IN P	LENS HOME
✓			✓	✓	✓	✓	✓	✓	✓

■ Parameters (*1,*2,*3,*4,*5,*6,*7,*8,*9,*10)

	OFF					ON				
Hexadecimal	30h	30h	30h	30h	30h	30h	30h	30h	30h	31h
Character	0	0	0	0	0	0	0	0	0	1

3.357. QUERY EDGE BLENDING - BLACK BORDER WIDTH - UPPER [QJU]

Hexadecimal	02h	41h	44h	5Ah	5Ah	3Bh	51h	4Ah	55h	03h
Character		A	D	Z	Z	;	Q	J	U	

■ Response (Callback)

In the period when the command can be accepted

Hexadecimal	02h	*1	*3	*5	*7	03h
Character		*2	*4	*6	*8	

Acceptability

SECURITY	STANDBY	ECO STANDBY	NO SIGNAL	SHUTTER	FREEZE	TEST PATTERN	REMOTE2	P IN P	LENS HOME
✓			✓	✓	✓	✓	✓	✓	✓

■ Parameters (*1,*2,*3,*4,*5,*6,*7,*8)

	0			1199			
Hexadecimal	30h			31h	31h	39h	39h
Character	0			1	1	9	9

3.358. QUERY EDGE BLENDING - BLACK BORDER WIDTH - LOWER [QJB]

Hexadecimal	02h	41h	44h	5Ah	5Ah	3Bh	51h	4Ah	4Bh	03h
Character		A	D	Z	Z	;	Q	J	B	

■ Response (Callback)

In the period when the command can be accepted

Hexadecimal	02h	*1	*3	*5	*7	03h
Character		*2	*4	*6	*8	

Acceptability

SECURITY	STANDBY	ECO STANDBY	NO SIGNAL	SHUTTER	FREEZE	TEST PATTERN	REMOTE2	P IN P	LENS HOME
✓			✓	✓	✓	✓	✓	✓	✓

■ Parameters (*1,*2,*3,*4,*5,*6,*7,*8)

	0			1199			
Hexadecimal	30h			31h	31h	39h	39h
Character	0			1	1	9	9

3.359. QUERY EDGE BLENDING - BLACK BORDER WIDTH - LEFT [QJL]

Hexadecimal	02h	41h	44h	5Ah	5Ah	3Bh	51h	4Ah	4Ch	03h
Character		A	D	Z	Z	;	Q	J	L	

■ Response (Callback)

In the period when the command can be accepted

Hexadecimal	02h	*1	*3	*5	*7	03h
Character		*2	*4	*6	*8	

Acceptability

SECURITY	STANDBY	ECO STANDBY	NO SIGNAL	SHUTTER	FREEZE	TEST PATTERN	REMOTE2	P IN P	LENS HOME
✓			✓	✓	✓	✓	✓	✓	✓

■ Parameters (*1,*2,*3,*4,*5,*6,*7,*8)

	0			1919			
Hexadecimal	30h			31h	39h	31h	39h
Character	0			1	9	1	9

3.360. QUERY EDGE BLENDING - BLACK BORDER WIDTH - RIGHT [QJR]

Hexadecimal	02h	41h	44h	5Ah	5Ah	3Bh	51h	4Ah	52h	03h
Character		A	D	Z	Z	;	Q	J	R	

■ Response (Callback)

In the period when the command can be accepted

Hexadecimal	02h	*1	*3	*5	*7	03h
Character		*2	*4	*6	*8	

Acceptability

SECURITY	STANDBY	ECO STANDBY	NO SIGNAL	SHUTTER	FREEZE	TEST PATTERN	REMOTE2	P IN P	LENS HOME
✓			✓	✓	✓	✓	✓	✓	✓

■ Parameters (*1,*2,*3,*4,*5,*6,*7,*8)

	0			1919			
Hexadecimal	30h		31h	39h	31h	39h	
Character	0		1	9	1	9	

3.361. QUERY EDGE BLENDING - BLACK BORDER WIDTH - UPPER KEYSTONE AREA [QVX:EBBI4]

Hexadecimal	02h	41h	44h	5Ah	5Ah	3Bh	51h	56h	58h	3Ah
Character		A	D	Z	Z	;	Q	V	X	:

Hexadecimal	45h	42h	42h	49h	34h	03h
Character	E	B	B	l	4	

■ Response (Callback)

In the period when the command can be accepted

Hexadecimal	02h	45h	42h	42h	49h	34h	3Dh	*1	*3	*5
Character		E	B	B	l	4	=	*2	*4	*6
Hexadecimal	*7	*9	*11	03h						
Character	*8	*10	*12							

Acceptability

SECURITY	STANDBY	ECO STANDBY	NO SIGNAL	SHUTTER	FREEZE	TEST PATTERN	REMOTE2	P IN P	LENS HOME
✓			✓	✓	✓	✓	✓	✓	✓

■ Parameters (*1,*2,*3,*4,*5,*6,*7,*8,*9,*10,*11,*12)

	-1199						+1199					
Hexadecimal	2Dh	30h	31h	31h	39h	39h	2Bh	30h	31h	31h	39h	39h
Character	-	0	1	1	9	9	+	0	1	1	9	9

3.362. QUERY EDGE BLENDING - BLACK BORDER WIDTH - LOWER KEYSTONE AREA [QVX:EBBI5]

Hexadecimal	02h	41h	44h	5Ah	5Ah	3Bh	51h	56h	58h	3Ah
Character		A	D	Z	Z	;	Q	V	X	:

Hexadecimal	45h	42h	42h	49h	35h	03h
Character	E	B	B	l	5	

■ Response (Callback)

In the period when the command can be accepted

Hexadecimal	02h	45h	42h	42h	49h	35h	3Dh	*1	*3	*5
Character		E	B	B	l	5	=	*2	*4	*6
Hexadecimal	*7	*9	*11	03h						
Character	*8	*10	*12							

Acceptability

SECURITY	STANDBY	ECO STANDBY	NO SIGNAL	SHUTTER	FREEZE	TEST PATTERN	REMOTE2	P IN P	LENS HOME
✓			✓	✓	✓	✓	✓	✓	✓

■ Parameters (*1,*2,*3,*4,*5,*6,*7,*8,*9,*10,*11,*12)

	-1199						+1199					
Hexadecimal	2Dh	30h	31h	31h	39h	39h	2Bh	30h	31h	31h	39h	39h
Character	-	0	1	1	9	9	+	0	1	1	9	9

3.363. QUERY EDGE BLENDING - BLACK BORDER WIDTH - LEFT KEYSTONE AREA [QVX:EBBI6]

Hexadecimal	02h	41h	44h	5Ah	5Ah	3Bh	51h	56h	58h	3Ah
Character		A	D	Z	Z	;	Q	V	X	:

Hexadecimal	45h	42h	42h	49h	36h	03h
Character	E	B	B	l	6	

■ Response (Callback)

In the period when the command can be accepted

Hexadecimal	02h	45h	42h	42h	49h	36h	3Dh	*1	*3	*5
Character		E	B	B	l	6	=	*2	*4	*6
Hexadecimal	*7	*9	*11	03h						
Character	*8	*10	*12							

Acceptability

SECURITY	STANDBY	ECO STANDBY	NO SIGNAL	SHUTTER	FREEZE	TEST PATTERN	REMOTE2	P IN P	LENS HOME
✓			✓	✓	✓	✓	✓	✓	✓

■ Parameters (*1,*2,*3,*4,*5,*6,*7,*8,*9,*10,*11,*12)

	-1919						+1919					
Hexadecimal	2Dh	30h	31h	39h	31h	39h	2Bh	30h	30h	30h	30h	31h
Character	-	0	1	9	1	9	+	0	1	9	1	9

3.364. QUERY EDGE BLENDING - BLACK BORDER WIDTH - RIGHT KEYSTONE AREA [QVX:EBBI7]

Hexadecimal	02h	41h	44h	5Ah	5Ah	3Bh	51h	56h	58h	3Ah
Character		A	D	Z	Z	;	Q	V	X	:
Hexadecimal	45h	42h	42h	49h	37h	03h				
Character	E	B	B	I	7					

■ Response (Callback)

In the period when the command can be accepted

Hexadecimal	02h	45h	42h	42h	49h	37h	3Dh	*1	*3	*5
Character		E	B	B	I	7	=	*2	*4	*6
Hexadecimal	*7	*9	*11	03h						
Character	*8	*10	*12							

Acceptability

SECURITY	STANDBY	ECO STANDBY	NO SIGNAL	SHUTTER	FREEZE	TEST PATTERN	REMOTE2	P IN P	LENS HOME
✓			✓	✓	✓	✓	✓	✓	✓

■ Parameters (*1,*2,*3,*4,*5,*6,*7,*8,*9,*10,*11,*12)

	-1919						+1919					
Hexadecimal	2Dh	30h	31h	39h	31h	39h	2Bh	30h	30h	30h	30h	31h
Character	-	0	1	9	1	9	+	0	1	9	1	9

3.365. QUERY EDGE BLENDING - OVERLAPPED BLACK LEVEL - UPPER [QVX:EBBS0]

Hexadecimal	02h	41h	44h	5Ah	5Ah	3Bh	51h	56h	58h	3Ah
Character		A	D	Z	Z	;	Q	V	X	:
Hexadecimal	45h	42h	42h	53h	30h	03h				
Character	E	B	B	S	0					

■ Response (Callback)

In the period when the command can be accepted

Hexadecimal	02h	45h	42h	42h	53h	30h	3Dh	*1	*3	*5	2Ch	
Character		E	B	B	S	0	=	*2	*4	*6	,	
Hexadecimal	*7	*9	*11	2Ch	*13	*15	*17	2Ch	*19	*21	*23	03h
Character	*8	*10	*12	,	*14	*16	*18	,	*20	*22	*24	

Acceptability

SECURITY	STANDBY	ECO STANDBY	NO SIGNAL	SHUTTER	FREEZE	TEST PATTERN	REMOTE2	P IN P	LENS HOME
✓			✓	✓	✓	✓	✓	✓	✓

■ Parameters (*1,*2,*3,*4,*5,*6) : White

	0			255		
Hexadecimal	30h	30h	30h	32h	35h	35h
Character	0	0	0	2	5	5

Parameters (*7,*8,*9,*10,*11,*12) : Red

	0			255		
Hexadecimal	30h	30h	30h	32h	35h	35h
Character	0	0	0	2	5	5

Parameters (*13,*14,*15,*16,*17,*18) : Green

	0			255		
Hexadecimal	30h	30h	30h	32h	35h	35h
Character	0	0	0	2	5	5

Parameters (*19,*20,*21,*22,*23,*24) : Blue

	0			255		
Hexadecimal	30h	30h	30h	32h	35h	35h
Character	0	0	0	2	5	5

3.366. QUERY EDGE BLENDING - OVERLAPPED BLACK LEVEL - LOWER [QVX:EBBS1]

Hexadecimal	02h	41h	44h	5Ah	5Ah	3Bh	51h	56h	58h	3Ah
Character		A	D	Z	Z	;	Q	V	X	:
Hexadecimal	45h	42h	42h	53h	31h	03h				
Character	E	B	B	S	1					

■ Response (Callback)

In the period when the command can be accepted

Hexadecimal	02h	45h	42h	42h	53h	31h	3Dh	*1	*3	*5	2Ch	
Character		E	B	B	S	1	=	*2	*4	*6	,	
Hexadecimal	*7	*9	*11	2Ch	*13	*15	*17	2Ch	*19	*21	*23	03h
Character	*8	*10	*12	,	*14	*16	*18	,	*20	*22	*24	

Acceptability

SECURITY	STANDBY	ECO STANDBY	NO SIGNAL	SHUTTER	FREEZE	TEST PATTERN	REMOTE2	P IN P	LENS HOME
✓			✓	✓	✓	✓	✓	✓	✓

■ Parameters (*1,*2,*3,*4,*5,*6) : White

	0			255		
Hexadecimal	30h	30h	30h	32h	35h	35h
Character	0	0	0	2	5	5

Parameters (*7,*8,*9,*10,*11,*12) : Red

	0			255		
Hexadecimal	30h	30h	30h	32h	35h	35h
Character	0	0	0	2	5	5

Parameters (*13,*14,*15,*16,*17,*18) : Green

	0			255		
Hexadecimal	30h	30h	30h	32h	35h	35h
Character	0	0	0	2	5	5

Parameters (*19,*20,*21,*22,*23,*24) : Blue

	0			255		
Hexadecimal	30h	30h	30h	32h	35h	35h
Character	0	0	0	2	5	5

3.367. QUERY EDGE BLENDING - OVERLAPPED BLACK LEVEL - LEFT [QVX:EBBS2]

Hexadecimal	02h	41h	44h	5Ah	5Ah	3Bh	51h	56h	58h	3Ah
Character		A	D	Z	Z	;	Q	V	X	:
Hexadecimal	45h	42h	42h	53h	32h	03h				
Character	E	B	B	S	2					

■ Response (Callback)

In the period when the command can be accepted

Hexadecimal	02h	45h	42h	42h	53h	32h	3Dh	*1	*3	*5	2Ch	
Character		E	B	B	S	2	=	*2	*4	*6	,	
Hexadecimal	*7	*9	*11	2Ch	*13	*15	*17	2Ch	*19	*21	*23	03h
Character	*8	*10	*12	,	*14	*16	*18	,	*20	*22	*24	

Acceptability

SECURITY	STANDBY	ECO STANDBY	NO SIGNAL	SHUTTER	FREEZE	TEST PATTERN	REMOTE2	P IN P	LENS HOME
✓			✓	✓	✓	✓	✓	✓	✓

■ Parameters (*1,*2,*3,*4,*5,*6) : White

	0			255		
Hexadecimal	30h	30h	30h	32h	35h	35h
Character	0	0	0	2	5	5

Parameters(*7,*8,*9,*10,*11,*12) : Red

	0			255		
Hexadecimal	30h	30h	30h	32h	35h	35h
Character	0	0	0	2	5	5

Parameters(*13,*14,*15,*16,*17,*18) : Green

	0			255		
Hexadecimal	30h	30h	30h	32h	35h	35h
Character	0	0	0	2	5	5

Parameters(*19,*20,*21,*22,*23,*24) : Blue

	0			255		
Hexadecimal	30h	30h	30h	32h	35h	35h
Character	0	0	0	2	5	5

3.368. QUERY EDGE BLENDING - OVERLAPPED BLACK LEVEL - RIGHT [QVX:EBBS3]

Hexadecimal	02h	41h	44h	5Ah	5Ah	3Bh	51h	56h	58h	3Ah
Character		A	D	Z	Z	;	Q	V	X	:
Hexadecimal	45h	42h	42h	53h	33h	03h				
Character	E	B	B	S	3					

■ Response (Callback)

In the period when the command can be accepted

Hexadecimal	02h	45h	42h	42h	53h	33h	3Dh	*1	*3	*5	2Ch	
Character		E	B	B	S	3	=	*2	*4	*6	,	
Hexadecimal	*7	*9	*11	2Ch	*13	*15	*17	2Ch	*19	*21	*23	03h
Character	*8	*10	*12	,	*14	*16	*18	,	*20	*22	*24	

Acceptability

SECURITY	STANDBY	ECO STANDBY	NO SIGNAL	SHUTTER	FREEZE	TEST PATTERN	REMOTE2	P IN P	LENS HOME
✓			✓	✓	✓	✓	✓	✓	✓

■ Parameters (*1,*2,*3,*4,*5,*6) : White

	0			255		
Hexadecimal	30h	30h	30h	32h	35h	35h
Character	0	0	0	2	5	5

Parameters (*7,*8,*9,*10,*11,*12) : Red

	0			255		
Hexadecimal	30h	30h	30h	32h	35h	35h
Character	0	0	0	2	5	5

Parameters (*13,*14,*15,*16,*17,*18) : Green

	0			255		
Hexadecimal	30h	30h	30h	32h	35h	35h
Character	0	0	0	2	5	5

Parameters (*19,*20,*21,*22,*23,*24) : Blue

	0			255		
Hexadecimal	30h	30h	30h	32h	35h	35h
Character	0	0	0	2	5	5

3.369. QUERY EDGE BLENDING - OVERLAPPED BLACK LEVEL - UPPER INTERLOCKED [QVX:EBII3]

Hexadecimal	02h	41h	44h	5Ah	5Ah	3Bh	51h	56h	58h	3Ah
Character		A	D	Z	Z	;	Q	V	X	:
Hexadecimal	45h	42h	49h	49h	33h	03h				
Character	E	B	I	I	3					

■ Response (Callback)

In the period when the command can be accepted

Hexadecimal	02h	45h	42h	49h	49h	33h	3Dh	2Bh	*1	*3
Character		E	B	I	I	3	=	+	*2	*4
Hexadecimal	*5	*7	*9	03h						
Character	*6	*8	*10							

Acceptability

SECURITY	STANDBY	ECO STANDBY	NO SIGNAL	SHUTTER	FREEZE	TEST PATTERN	REMOTE2	P IN P	LENS HOME
✓			✓	✓	✓	✓	✓	✓	✓

■ Parameters (*1,*2,*3,*4,*5,*6,*7,*8,*9,*10)

	OFF					ON				
Hexadecimal	30h	30h	30h	30h	30h	30h	30h	30h	30h	31h
Character	0	0	0	0	0	0	0	0	0	1

3.370. QUERY EDGE BLENDING - OVERLAPPED BLACK LEVEL - LOWER INTERLOCKED [QVX:EBII4]

Hexadecimal	02h	41h	44h	5Ah	5Ah	3Bh	51h	56h	58h	3Ah
Character		A	D	Z	Z	;	Q	V	X	:
Hexadecimal	45h	42h	49h	49h	34h	03h				
Character	E	B	I	I	4					

■ Response (Callback)

In the period when the command can be accepted

Hexadecimal	02h	45h	42h	49h	49h	34h	3Dh	2Bh	*1	*3
Character		E	B	I	I	4	=	+	*2	*4
Hexadecimal	*5	*7	*9	03h						
Character	*6	*8	*10							

Acceptability

SECURITY	STANDBY	ECO STANDBY	NO SIGNAL	SHUTTER	FREEZE	TEST PATTERN	REMOTE2	P IN P	LENS HOME
✓			✓	✓	✓	✓	✓	✓	✓

■ Parameters (*1,*2,*3,*4,*5,*6,*7,*8,*9,*10)

	OFF					ON				
Hexadecimal	30h	30h	30h	30h	30h	30h	30h	30h	30h	31h
Character	0	0	0	0	0	0	0	0	0	1

3.371. QUERY EDGE BLENDING - OVERLAPPED BLACK LEVEL - LEFT INTERLOCKED [QVX:EBII5]

Hexadecimal	02h	41h	44h	5Ah	5Ah	3Bh	51h	56h	58h	3Ah
Character		A	D	Z	Z	;	Q	V	X	:
Hexadecimal	45h	42h	49h	49h	35h	03h				
Character	E	B	I	I	5					

■ Response (Callback)

In the period when the command can be accepted

Hexadecimal	02h	45h	42h	49h	49h	35h	3Dh	2Bh	*1	*3
Character		E	B	I	I	5	=	+	*2	*4
Hexadecimal	*5	*7	*9	03h						
Character	*6	*8	*10							

Acceptability

SECURITY	STANDBY	ECO STANDBY	NO SIGNAL	SHUTTER	FREEZE	TEST PATTERN	REMOTE2	P IN P	LENS HOME
✓			✓	✓	✓	✓	✓	✓	✓

■ Parameters (*1,*2,*3,*4,*5,*6,*7,*8,*9,*10)

	OFF					ON				
Hexadecimal	30h	30h	30h	30h	30h	30h	30h	30h	30h	31h
Character	0	0	0	0	0	0	0	0	0	1

3.372. QUERY EDGE BLENDING - OVERLAPPED BLACK LEVEL - RIGHT INTERLOCKED [QVX:EBII6]

Hexadecimal	02h	41h	44h	5Ah	5Ah	3Bh	51h	56h	58h	3Ah
Character		A	D	Z	Z	;	Q	V	X	:
Hexadecimal	45h	42h	49h	49h	36h	03h				
Character	E	B	I	I	6					

■ Response (Callback)

In the period when the command can be accepted

Hexadecimal	02h	45h	42h	49h	49h	36h	3Dh	2Bh	*1	*3
Character		E	B	I	I	6	=	+	*2	*4
Hexadecimal	*5	*7	*9	03h						
Character	*6	*8	*10							

Acceptability

SECURITY	STANDBY	ECO STANDBY	NO SIGNAL	SHUTTER	FREEZE	TEST PATTERN	REMOTE2	P IN P	LENS HOME
✓			✓	✓	✓	✓	✓	✓	✓

■ Parameters (*1,*2,*3,*4,*5,*6,*7,*8,*9,*10)

	OFF					ON				
Hexadecimal	30h	30h	30h	30h	30h	30h	30h	30h	30h	31h
Character	0	0	0	0	0	0	0	0	0	1

3.373. QUERY FRAME RESPONSE [QVX:FDYI0]

Hexadecimal	02h	41h	44h	5Ah	5Ah	3Bh	51h	56h	58h	3Ah
Character		A	D	Z	Z	;	Q	V	X	:
Hexadecimal	46h	44h	59h	49h	30h	03h				
Character	F	D	Y	I	0					

■ Response (Callback)

In the period when the command can be accepted

Hexadecimal	02h	46h	44h	59h	49h	30h	3Dh	2Bh
Character		F	D	Y	I	0	=	+
Hexadecimal	*1	*3	*5	*7	*9	03h		
Character	*2	*4	*6	*8	*10			

Acceptability

SECURITY	STANDBY	ECO STANDBY	NO SIGNAL	SHUTTER	FREEZE	TEST PATTERN	REMOTE2	P IN P	LENS HOME
✓			✓	✓	✓	✓	✓	✓	✓

■ Parameters (*1,*2,*3,*4,*5,*6,*7,*8,*9,*10)

	NORMAL					FAST					FIXED				
Hexadecimal	30h	30h	30h	30h	30h	30h	30h	30h	30h	31h	30h	30h	30h	30h	35h
Character	0	0	0	0	0	0	0	0	0	1	0	0	0	0	5

3.374. QUERY RASTER POSITION - HORIZONTAL [QRH]

Hexadecimal	02h	41h	44h	5Ah	5Ah	3Bh	51h	52h	48h	03h
Character		A	D	Z	Z	;	Q	R	H	

■ Response (Callback)

In the period when the command can be accepted

Hexadecimal	02h	*1	*3	*5	*7	03h
Character		*2	*4	*6	*8	

Acceptability

SECURITY	STANDBY	ECO STANDBY	NO SIGNAL	SHUTTER	FREEZE	TEST PATTERN	REMOTE2	P IN P	LENS HOME
✓				✓	✓	✓	✓	✓	✓

■ Parameters (*1,*2,*3,*4,*5,*6,*7,*8)

	-2048				-2047			
Hexadecimal	32h	39h	35h	32h	32h	39h	35h	33h
Character	2	9	5	2	2	9	5	3
	+2046				+2047			
Hexadecimal	37h	30h	34h	36h	37h	30h	34h	37h
Character	7	0	4	6	7	0	4	7

3.375. QUERY RASTER POSITION - VERTICAL [QRV]

Hexadecimal	02h	41h	44h	5Ah	5Ah	3Bh	51h	52h	56h	03h
Character		A	D	Z	Z	;	Q	R	V	

■ Response (Callback)

In the period when the command can be accepted

Hexadecimal	02h	*1	*3	*5	*7	03h
Character		*2	*4	*6	*8	

Acceptability

SECURITY	STANDBY	ECO STANDBY	NO SIGNAL	SHUTTER	FREEZE	TEST PATTERN	REMOTE2	P IN P	LENS HOME
✓				✓	✓	✓	✓	✓	✓

■ Parameters (*1,*2,*3,*4,*5,*6,*7,*8)

	-2048				-2047			
Hexadecimal	32h	39h	35h	32h	32h	39h	35h	33h
Character	2	9	5	2	2	9	5	3
	+2046				+2047			
Hexadecimal	37h	30h	34h	36h	37h	30h	34h	37h
Character	7	0	4	6	7	0	4	7

3.376. QUERY DISPLAY LANGUAGE [QLG]

Hexadecimal	02h	41h	44h	5Ah	5Ah	3Bh	51h	4Ch	47h	03h
Character		A	D	Z	Z	;	Q	L	G	

■ Response (Callback)

In the period when the command can be accepted

Hexadecimal	02h	*1	*3	*5	03h
Character		*2	*4	*6	

Acceptability

SECURITY	STANDBY	ECO STANDBY	NO SIGNAL	SHUTTER	FREEZE	TEST PATTERN	REMOTE2	P IN P	LENS HOME
✓	✓		✓	✓	✓	✓	✓	✓	✓

■ Parameters (*1,*2,*3,*4,*5,*6)

	English			German			France		
Hexadecimal	45h	4Eh	47h	44h	45h	55h	46h	52h	41h
Character	E	N	G	D	E	U	F	R	A
	Spanish			Italian			Portuguese		
Hexadecimal	45h	53h	50h	49h	54h	4Ch	50h	4Fh	52h
Character	E	S	P	I	T	L	P	O	R
	Japanese			Chinese			Russian		
Hexadecimal	4Ah	50h	4Eh	43h	48h	49h	52h	55h	53h
Character	J	P	N	C	H	I	R	U	S
	Korean								
Hexadecimal	4Bh	4Fh	52h						
Character	K	O	R						

3.377. QUERY COLOR MATCHING [QVX:CMAI0]

Hexadecimal	02h	41h	44h	5Ah	5Ah	3Bh	51h	56h	58h	3Ah
Character		A	D	Z	Z	;	Q	V	X	:
Hexadecimal	43h	4Dh	41h	49h	30h	03h				
Character	C	M	A	I	0					

■ Response (Callback)

In the period when the command can be accepted

Hexadecimal	02h	43h	4Dh	41h	49h	30h	3Dh	2Bh
Character		C	M	A	I	0	=	+
Hexadecimal	*1	*3	*5	*7	*9	03h		
Character	*2	*4	*6	*8	*10			

Acceptability

SECURITY	STANDBY	ECO STANDBY	NO SIGNAL	SHUTTER	FREEZE	TEST PATTERN	REMOTE2	P IN P	LENS HOME
✓			✓	✓	✓	✓	✓	✓	✓

■ Parameters (*1,*2,*3,*4,*5,*6,*7,*8,*9,*10)

	OFF					3COLORS					7COLORS				
Hexadecimal	30h	30h	30h	30h	30h	30h	30h	30h	30h	31h	30h	30h	30h	30h	32h
30hCharacter	0	0	0	0	0	0	0	0	0	1	0	0	0	0	2
	MEASURED														
Hexadecimal	30h	30h	30h	30h	34h										
Character	0	0	0	0	4										

3.378. QUERY COLOR CORRECTION [QMC]

Hexadecimal	02h	41h	44h	5Ah	5Ah	3Bh	51h	4Dh	43h	03h
Character		A	D	Z	Z	;	Q	M	C	

■ Response (Callback)

In the period when the command can be accepted

Hexadecimal	02h	*1	03h
Character		*2	

Acceptability

SECURITY	STANDBY	ECO STANDBY	NO SIGNAL	SHUTTER	FREEZE	TEST PATTERN	REMOTE2	P IN P	LENS HOME
✓			✓	✓	✓	✓	✓	✓	✓

■ Parameters (*1,*2)

	OFF	USER
Hexadecimal	30h	31h
Character	0	1

3.379. QUERY COLOR CORRECTION - RED [QVX:CCRI0]

Hexadecimal	02h	41h	44h	5Ah	5Ah	3Bh	51h	56h	58h	3Ah
Character		A	D	Z	Z	;	Q	V	X	:
Hexadecimal	43h	43h	52h	49h	30h	03h				
Character	C	C	R	I	0					

■ Response (Callback)

In the period when the command can be accepted

Hexadecimal	02h	43h	43h	52h	49h	30h	3Dh	*1	*3	*5
Character		C	C	R	I	0	=	*2	*4	*6
Hexadecimal	*7	*9	*11	03h						
Character	*8	*10	*12							

Acceptability

SECURITY	STANDBY	ECO STANDBY	NO SIGNAL	SHUTTER	FREEZE	TEST PATTERN	REMOTE2	P IN P	LENS HOME
✓			✓	✓	✓	✓	✓	✓	✓

■ Parameters (*1,*2,*3,*4,*5,*6,*7,*8,*9,*10,*11,*12)

	-30						-29					
Hexadecimal	2Dh	30h	30h	30h	33h	30h	2Dh	30h	30h	30h	32h	39h
Character	—	0	0	0	3	0	—	0	0	0	2	9
	29						30					
Hexadecimal	2Bh	30h	30h	30h	32h	39h	2Bh	30h	30h	30h	33h	30h
Character	+	0	0	0	2	9	+	0	0	0	3	0

3.380. QUERY COLOR CORRECTION - GREEN [QVX:CCRI1]

Hexadecimal	02h	41h	44h	5Ah	5Ah	3Bh	51h	56h	58h	3Ah
Character		A	D	Z	Z	;	Q	V	X	:
Hexadecimal	43h	43h	52h	49h	31h	03h				
Character	C	C	R	I	1					

■ Response (Callback)

In the period when the command can be accepted

Hexadecimal	02h	43h	43h	52h	49h	31h	3Dh	*1	*3	*5
Character		C	C	R	I	1	=	*2	*4	*6
Hexadecimal	*7	*9	*11	03h						
Character	*8	*10	*12							

Acceptability

SECURITY	STANDBY	ECO STANDBY	NO SIGNAL	SHUTTER	FREEZE	TEST PATTERN	REMOTE2	P IN P	LENS HOME
✓			✓	✓	✓	✓	✓	✓	✓

■ Parameters (*1,*2,*3,*4,*5,*6,*7,*8,*9,*10,*11,*12)

	-30						-29					
Hexadecimal	2Dh	30h	30h	30h	33h	30h	2Dh	30h	30h	30h	32h	39h
Character	—	0	0	0	3	0	—	0	0	0	2	9
	29						30					
Hexadecimal	2Bh	30h	30h	30h	32h	39h	2Bh	30h	30h	30h	33h	30h
Character	+	0	0	0	2	9	+	0	0	0	3	0

3.381. QUERY COLOR CORRECTION - BLUE [QVX:CCR12]

Hexadecimal	02h	41h	44h	5Ah	5Ah	3Bh	51h	56h	58h	3Ah
Character		A	D	Z	Z	;	Q	V	X	:
Hexadecimal	43h	43h	52h	49h	32h	03h				
Character	C	C	R	I	2					

■ Response (Callback)

In the period when the command can be accepted

Hexadecimal	02h	43h	43h	52h	49h	32h	3Dh	*1	*3	*5
Character		C	C	R	I	2	=	*2	*4	*6
Hexadecimal	*7	*9	*11	03h						
Character	*8	*10	*12							

Acceptability

SECURITY	STANDBY	ECO STANDBY	NO SIGNAL	SHUTTER	FREEZE	TEST PATTERN	REMOTE2	P IN P	LENS HOME
✓			✓	✓	✓	✓	✓	✓	✓

■ Parameters (*1,*2,*3,*4,*5,*6,*7,*8,*9,*10,*11,*12)

	-30						-29					
Hexadecimal	2Dh	30h	30h	30h	33h	30h	2Dh	30h	30h	30h	32h	39h
Character	—	0	0	0	3	0	—	0	0	0	2	9
	29						30					
Hexadecimal	2Bh	30h	30h	30h	32h	39h	2Bh	30h	30h	30h	33h	30h
Character	+	0	0	0	2	9	+	0	0	0	3	0

3.382. QUERY COLOR CORRECTION - CYAN [QVX:CCR13]

Hexadecimal	02h	41h	44h	5Ah	5Ah	3Bh	51h	56h	58h	3Ah
Character		A	D	Z	Z	;	Q	V	X	:
Hexadecimal	43h	43h	52h	49h	33h	03h				
Character	C	C	R	I	3					

■ Response (Callback)

In the period when the command can be accepted

Hexadecimal	02h	43h	43h	52h	49h	33h	3Dh	*1	*3	*5
Character		C	C	R	I	3	=	*2	*4	*6
Hexadecimal	*7	*9	*11	03h						
Character	*8	*10	*12							

Acceptability

SECURITY	STANDBY	ECO STANDBY	NO SIGNAL	SHUTTER	FREEZE	TEST PATTERN	REMOTE2	P IN P	LENS HOME
✓			✓	✓	✓	✓	✓	✓	✓

■ Parameters (*1,*2,*3,*4,*5,*6,*7,*8,*9,*10,*11,*12)

	-30						-29					
Hexadecimal	2Dh	30h	30h	30h	33h	30h	2Dh	30h	30h	30h	32h	39h
Character	—	0	0	0	3	0	—	0	0	0	2	9
	29						30					
Hexadecimal	2Bh	30h	30h	30h	32h	39h	2Bh	30h	30h	30h	33h	30h
Character	+	0	0	0	2	9	+	0	0	0	3	0

3.383. QUERY COLOR CORRECTION - MAGENTA [QVX:CCR14]

Hexadecimal	02h	41h	44h	5Ah	5Ah	3Bh	51h	56h	58h	3Ah
Character		A	D	Z	Z	;	Q	V	X	:
Hexadecimal	43h	43h	52h	49h	34h	03h				
Character	C	C	R	I	4					

■ Response (Callback)

In the period when the command can be accepted

Hexadecimal	02h	43h	43h	52h	49h	34h	3Dh	*1	*3	*5
Character		C	C	R	I	4	=	*2	*4	*6
Hexadecimal	*7	*9	*11	03h						
Character	*8	*10	*12							

Acceptability

SECURITY	STANDBY	ECO STANDBY	NO SIGNAL	SHUTTER	FREEZE	TEST PATTERN	REMOTE2	P IN P	LENS HOME
✓			✓	✓	✓	✓	✓	✓	✓

■ Parameters (*1,*2,*3,*4,*5,*6,*7,*8,*9,*10,*11,*12)

	-30						-29					
Hexadecimal	2Dh	30h	30h	30h	33h	30h	2Dh	30h	30h	30h	32h	39h
Character	—	0	0	0	3	0	—	0	0	0	2	9
	29						30					
Hexadecimal	2Bh	30h	30h	30h	32h	39h	2Bh	30h	30h	30h	33h	30h
Character	+	0	0	0	2	9	+	0	0	0	3	0

3.384. QUERY COLOR CORRECTION - YELLOW [QVX:CCRI5]

Hexadecimal	02h	41h	44h	5Ah	5Ah	3Bh	51h	56h	58h	3Ah
Character		A	D	Z	Z	;	Q	V	X	:
Hexadecimal	43h	43h	52h	49h	32h	03h				
Character	C	C	R	I	5					

■ Response (Callback)

In the period when the command can be accepted

Hexadecimal	02h	43h	43h	52h	49h	35h	3Dh	*1	*3	*5
Character		C	C	R	I	5	=	*2	*4	*6
Hexadecimal	*7	*9	*11	03h						
Character	*8	*10	*12							

Acceptability

SECURITY	STANDBY	ECO STANDBY	NO SIGNAL	SHUTTER	FREEZE	TEST PATTERN	REMOTE2	P IN P	LENS HOME
✓			✓	✓	✓	✓	✓	✓	✓

■ Parameters (*1,*2,*3,*4,*5,*6,*7,*8,*9,*10,*11,*12)

	-30						-29					
Hexadecimal	2Dh	30h	30h	30h	33h	30h	2Dh	30h	30h	30h	32h	39h
Character	—	0	0	0	3	0	—	0	0	0	2	9
	29						30					
Hexadecimal	2Bh	30h	30h	30h	32h	39h	2Bh	30h	30h	30h	33h	30h
Character	+	0	0	0	2	9	+	0	0	0	3	0

3.385. QUERY SCREEN SETTING - SCREEN FORMAT [QSF]

Hexadecimal	02h	41h	44h	5Ah	5Ah	3Bh	51h	53h	46h	03h
Character		A	D	Z	Z	;	Q	S	F	

■ Response (Callback)

In the period when the command can be accepted

Hexadecimal	02h	*1	03h
Character		*2	

Acceptability

SECURITY	STANDBY	ECO STANDBY	NO SIGNAL	SHUTTER	FREEZE	TEST PATTERN	REMOTE2	P IN P	LENS HOME
✓			✓	✓	✓	✓	✓	✓	✓

■ Parameters (*1,*2)

	16:10	*1	16:9	4:3	*2
Hexadecimal	30h		31h	32h	
Character	0		1	2	

*1 : Only for DZ780(FDZ88C) and DW750(FDW85C)

*2 : Only for DZ780(FDZ88C) and DX820(FDX92C, FD605C)

3.386. QUERY SCREEN SETTING - SCREEN POSITION - VERTICAL [QVX:VSPI0]

Hexadecimal	02h	41h	44h	5Ah	5Ah	3Bh	51h	56h	58h	3Ah
Character		A	D	Z	Z	;	Q	V	X	:
Hexadecimal	56h	53h	50h	49h	30h	03h				
Character	V	S	P	I	0					

■ Response (Callback)

In the period when the command can be accepted

Hexadecimal	02h	56h	53h	50h	49h	30h	3Dh	*1	*3	*5
Character		V	S	P	I	0	=	*2	*4	*6
Hexadecimal	*7	*9	*11	03h						
Character	*8	*10	*12							

Acceptability

SECURITY	STANDBY	ECO STANDBY	NO SIGNAL	SHUTTER	FREEZE	TEST PATTERN	REMOTE2	P IN P	LENS HOME
✓			✓	✓	✓	✓	✓	✓	✓

■ Parameters (*1,*2,*3,*4,*5,*6,*7,*8,*9,*10,*11,*12)

DZ780(FDZ88C), SCREEN FORMAT 16:9

	-60						-59					
Hexadecimal	2Dh	30h	30h	30h	36h	30h	2Dh	30h	30h	30h	35h	39h
Character	—	0	0	0	6	0	—	0	0	0	5	9
	59						60					
Hexadecimal	2Bh	30h	30h	30h	35h	39h	2Bh	30h	30h	30h	30h	30h
Character	+	0	0	0	5	9	+	0	0	0	6	0

DW750(FDW85C), SCREEN FORMAT 16:9

	-40						-39					
Hexadecimal	2Dh	30h	30h	30h	34h	30h	2Dh	30h	30h	30h	33h	39h
Character	—	0	0	0	4	0	—	0	0	0	3	9
	39						40					
Hexadecimal	2Bh	30h	30h	30h	33h	39h	2Bh	30h	30h	30h	34h	30h
Character	+	0	0	0	3	9	+	0	0	0	4	0

DX820(FDX92C, FD605C), SCREEN FORMAT 16:9

	-96						-95					
Hexadecimal	2Dh	30h	30h	30h	39h	36h	2Dh	30h	30h	30h	39h	35h
Character	—	0	0	0	9	6	—	0	0	0	9	5
	95						96					
Hexadecimal	2Bh	30h	30h	30h	39h	35h	2Bh	30h	30h	30h	39h	36h
Character	+	0	0	0	9	5	+	0	0	0	9	6

■ Note:

- DZ780(FDZ88C) : When the screen format is set as [16:10] or [4:3], ER401 is returned.
- DW750(FDW85C) : When the screen format is set as [16:10], ER401 is returned.
- DX820(FDX92C,FD605C) : When the screen format is set as [4:3], ER401 is returned.

3.387. QUERY SCREEN SETTING - SCREEN POSITION - HORIZONTAL [QVX:HSPI0]

Hexadecimal	02h	41h	44h	5Ah	5Ah	3Bh	51h	56h	58h	3Ah
Character		A	D	Z	Z	;	Q	V	X	:
Hexadecimal	48h	53h	50h	49h	30h	03h				
Character	H	S	P	I	0					

■ Response (Callback)

In the period when the command can be accepted

Hexadecimal	02h	48h	53h	50h	49h	30h	3Dh	*1	*3	*5
Character		H	S	P	I	0	=	*2	*4	*6
Hexadecimal	*7	*9	*11	03h						
Character	*8	*10	*12							

Acceptability

SECURITY	STANDBY	ECO STANDBY	NO SIGNAL	SHUTTER	FREEZE	TEST PATTERN	REMOTE2	P IN P	LENS HOME
✓			✓	✓	✓	✓	✓	✓	✓

■ Parameters (*1,*2,*3,*4,*5,*6,*7,*8,*9,*10,*11,*12)

DZ780(FDZ88C), SCREEN FORMAT 4:3

	-160						-159					
Hexadecimal	2Dh	30h	30h	31h	36h	30h	2Dh	30h	30h	31h	35h	39h
Character	—	0	0	1	6	0	—	0	0	1	5	9
	159						160					
Hexadecimal	2Bh	30h	30h	31h	35h	39h	2Bh	30h	30h	31h	36h	30h
Character	+	0	0	1	5	9	+	0	0	1	6	0

■ Note:

- Only effective for DZ780(FDZ88C), other models return ER401.
- DZ780(FDZ88C) : When the screen format is set as [16:10] or [16:9], ER401 is returned.

3.388. QUERY AUTO SIGNAL [QVX:AASIO]

Hexadecimal	02h	41h	44h	5Ah	5Ah	3Bh	51h	56h	58h	3Ah
Character		A	D	Z	Z	;	Q	V	X	:
Hexadecimal	41h	41h	53h	49h	30h	03h				
Character	A	A	S	I	0					

■ Response (Callback)

In the period when the command can be accepted

Hexadecimal	02h	41h	41h	53h	49h	30h	3Dh	2Bh
Character		A	A	S	I	0	=	+
Hexadecimal	*1	*3	*5	*7	*9	03h		
Character	*2	*4	*6	*8	*10			

Acceptability

SECURITY	STANDBY	ECO STANDBY	NO SIGNAL	SHUTTER	FREEZE	TEST PATTERN	REMOTE2	P IN P	LENS HOME
✓			✓	✓	✓	✓	✓	✓	✓

■ Parameters (*1,*2,*3,*4,*5,*6,*7,*8,*9,*10)

	OFF					ON				
Hexadecimal	30h	30h	30h	30h	30h	30h	30h	30h	30h	31h
Character	0	0	0	0	0	0	0	0	0	1

3.389. QUERY AUTO SETUP - MODE [QAM]

Hexadecimal	02h	41h	44h	5Ah	5Ah	3Bh	51h	41h	4Dh	03h
Character		A	D	Z	Z	;	Q	A	M	

■ Response (Callback)

In the period when the command can be accepted

Hexadecimal	02h	*1	03h
Character		*2	

Acceptability

SECURITY	STANDBY	ECO STANDBY	NO SIGNAL	SHUTTER	FREEZE	TEST PATTERN	REMOTE2	P IN P	LENS HOME
✓	✓		✓	✓	✓	✓	✓	✓	✓

■ Parameters (*1,*2)

	USER	DEFAULT	WIDE
Hexadecimal	30h	31h	32h
Character	0	1	2

3.390. QUERY AUTO SETUP - POSITION [QVX:APAI0]

Hexadecimal	02h	41h	44h	5Ah	5Ah	3Bh	51h	56h	58h	3Ah
Character		A	D	Z	Z	:	Q	V	X	:
Hexadecimal	41h	50h	41h	49h	30h	03h				
Character	A	P	A	I	0					

■ Response (Callback)

In the period when the command can be accepted

Hexadecimal	02h	41h	50h	41h	49h	30h	3Dh	2Bh
Character		A	P	A	I	0	=	+
Hexadecimal	*1	*3	*5	*7	*9	03h		
Character	*2	*4	*6	*8	*10			

Acceptability

SECURITY	STANDBY	ECO STANDBY	NO SIGNAL	SHUTTER	FREEZE	TEST PATTERN	REMOTE2	P IN P	LENS HOME
✓	✓		✓	✓	✓	✓	✓	✓	✓

■ Parameters (*1,*2,*3,*4,*5,*6,*7,*8,*9,*10)

	OFF					ON				
Hexadecimal	30h	30h	30h	30h	30h	30h	30h	30h	30h	31h
Character	0	0	0	0	0	0	0	0	0	1

3.391. QUERY AUTO SETUP - SIGNAL LEVEL [QVX:ASLI0]

Hexadecimal	02h	41h	44h	5Ah	5Ah	3Bh	51h	56h	58h	3Ah
Character		A	D	Z	Z	:	Q	V	X	:
Hexadecimal	41h	53h	4Ch	49h	30h	03h				
Character	A	S	L	I	0					

■ Response (Callback)

In the period when the command can be accepted

Hexadecimal	02h	41h	53h	4Ch	49h	30h	3Dh	2Bh
Character		A	S	L	I	0	=	+
Hexadecimal	*1	*3	*5	*7	*9	03h		
Character	*2	*4	*6	*8	*10			

Acceptability

SECURITY	STANDBY	ECO STANDBY	NO SIGNAL	SHUTTER	FREEZE	TEST PATTERN	REMOTE2	P IN P	LENS HOME
✓	✓		✓	✓	✓	✓	✓	✓	✓

■ Parameters (*1,*2,*3,*4,*5,*6,*7,*8,*9,*10)

	OFF					ON				
Hexadecimal	30h	30h	30h	30h	30h	30h	30h	30h	30h	31h
Character	0	0	0	0	0	0	0	0	0	1

3.392. QUERY BACKUP INPUT SETTING – BACKUP INPUT MODE [QVX:BACI2]

Hexadecimal	02h	41h	44h	5Ah	5Ah	3Bh	51h	56h	88h	3Ah
Character		A	D	Z	Z	:	Q	V	X	:
Hexadecimal	42h	41h	43h	49h	32h	03h				
Character	B	A	C	I	2					

■ Response (Callback)

In the period when the command can be accepted

Hexadecimal	02h	42h	41h	43h	49h	32h	3Dh	2Bh
Character		B	A	C	I	2	=	+
Hexadecimal	*1	*3	*5	*7	*9	03h		
Character	*2	*4	*6	*8	*10			

Acceptability

SECURITY	STANDBY	ECO STANDBY	NO SIGNAL	SHUTTER	FREEZE	TEST PATTERN	REMOTE2	P IN P	LENS HOME
✓	✓		✓	✓	✓	✓	✓		✓

■ Parameters (*1,*2,*3,*4,*5,*6,*7,*8,*9,*10)

	OFF					ON				
Hexadecimal	30h	30h	30h	30h	30h	30h	30h	30h	30h	31h
Character	0	0	0	0	0	0	0	0	0	1

3.393. QUERY BACKUP INPUT SETTING – AUTOMATIC SWITCHING [QVX:BACI3]

Hexadecimal	02h	41h	44h	5Ah	5Ah	3Bh	51h	56h	88h	3Ah
Character		A	D	Z	Z	;	Q	V	X	:
Hexadecimal	42h	41h	43h	49h	33h	03h				
Character	B	A	C	I	3					

■ Response (Callback)

In the period when the command can be accepted

Hexadecimal	02h	42h	41h	43h	49h	33h	3Dh	2Bh
Character		B	A	C	I	3	=	+
Hexadecimal	*1	*3	*5	*7	*9	03h		
Character	*2	*4	*6	*8	*10			

Acceptability

SECURITY	STANDBY	ECO STANDBY	NO SIGNAL	SHUTTER	FREEZE	TEST PATTERN	REMOTE2	P IN P	LENS HOME
✓	✓		✓	✓	✓	✓	✓		✓

■ Parameters (*1,*2,*3,*4,*5,*6,*7,*8,*9,*10)

	DISABLE					ENABLE				
Hexadecimal	30h	30h	30h	30h	30h	30h	30h	30h	30h	31h
Character	0	0	0	0	0	0	0	0	0	1

3.394. QUERY BACKUP INPUT SETTING – BACKUP INPUT STATUS [QVX:BACI4]

Hexadecimal	02h	41h	44h	5Ah	5Ah	3Bh	51h	56h	88h	3Ah
Character		A	D	Z	Z	;	Q	V	X	:
Hexadecimal	42h	41h	43h	49h	34h	03h				
Character	B	A	C	I	4					

■ Response (Callback)

In the period when the command can be accepted

Hexadecimal	02h	42h	41h	43h	49h	34h	3Dh	2Bh
Character		B	A	C	I	4	=	+
Hexadecimal	*1	*3	*5	*7	*9	03h		
Character	*2	*4	*6	*8	*10			

Acceptability

SECURITY	STANDBY	ECO STANDBY	NO SIGNAL	SHUTTER	FREEZE	TEST PATTERN	REMOTE2	P IN P	LENS HOME
✓			✓	✓			✓		✓

■ Parameters (*1,*2,*3,*4,*5,*6,*7,*8,*9,*10)

	INACTIVE					ACTIVE				
Hexadecimal	30h	30h	30h	30h	30h	30h	30h	30h	30h	31h
Character	0	0	0	0	0	0	0	0	0	1

3.395. QUERY RGB IN - RGB1 INPUT SETTING [QVX:RYCI1]

Hexadecimal	02h	41h	44h	5Ah	5Ah	3Bh	51h	56h	58h	3Ah
Character		A	D	Z	Z	;	Q	V	X	:
Hexadecimal	52h	59h	43	49h	31h	03h				
Character	R	Y	C	I	1					

■ Response (Callback)

In the period when the command can be accepted

Hexadecimal	02h	52h	59h	43	49h	31h	3Dh	2Bh	*1	*3
Character		R	Y	C	I	1	=	+	*2	*4
Hexadecimal	*5	*7	*9	03h						
Character	*6	*8	*10							

Acceptability

SECURITY	STANDBY	ECO STANDBY	NO SIGNAL	SHUTTER	FREEZE	TEST PATTERN	REMOTE2	P IN P	LENS HOME
✓			✓	✓	✓	✓	✓	✓	✓

■ Parameters (*1,*2,*3,*4,*5,*6,*7,*8,*9,*10)

	RGB/YPBPR					Y/C				
Hexadecimal	30h	30h	30h	30h	30h	30h	30h	30h	30h	31h
Character	0	0	0	0	0	0	0	0	0	1

3.396. QUERY RGB IN - RGB1 SYNC SLICE LEVEL [QVX:STRI0]

Hexadecimal	02h	41h	44h	5Ah	5Ah	3Bh	51h	56h	58h	3Ah
Character		A	D	Z	Z	;	Q	V	X	:
Hexadecimal	53h	54h	52h	49h	30h	03h				
Character	S	T	R	I	0					

■ Response (Callback)

In the period when the command can be accepted

Hexadecimal	02h	53h	54h	52h	49h	30h	3Dh	2Bh	*1	*3
Character		S	T	R	I	0	=	+	*2	*4
Hexadecimal	*5	*7	*9	03h						
Character	*6	*8	*10							

Acceptability

SECURITY	STANDBY	ECO STANDBY	NO SIGNAL	SHUTTER	FREEZE	TEST PATTERN	REMOTE2	P IN P	LENS HOME
✓	✓		✓	✓	✓	✓	✓	✓	✓

■ Parameters (*1,*2,*3,*4,*5,*6,*7,*8,*9,*10)

	LOW					HIGH				
Hexadecimal	30h	30h	30h	30h	30h	30h	30h	30h	30h	31h
Character	0	0	0	0	0	0	0	0	0	1

3.397. QUERY RGB IN - RGB2 SYNC SLICE LEVEL [QVX:STRI1]

Hexadecimal	02h	41h	44h	5Ah	5Ah	3Bh	51h	56h	58h	3Ah
Character		A	D	Z	Z	;	Q	V	X	:
Hexadecimal	53h	54h	52h	49h	31h	03h				
Character	S	T	R	I	1					

■ Response (Callback)

In the period when the command can be accepted

Hexadecimal	02h	53h	54h	52h	49h	31h	3Dh	2Bh	*1	*3
Character		S	T	R	I	1	=	+	*2	*4
Hexadecimal	*5	*7	*9	03h						
Character	*6	*8	*10							

Acceptability

SECURITY	STANDBY	ECO STANDBY	NO SIGNAL	SHUTTER	FREEZE	TEST PATTERN	REMOTE2	P IN P	LENS HOME
✓	✓		✓	✓	✓	✓	✓	✓	✓

■ Parameters (*1,*2,*3,*4,*5,*6,*7,*8,*9,*10)

	LOW					HIGH				
Hexadecimal	30h	30h	30h	30h	30h	30h	30h	30h	30h	31h
Character	0	0	0	0	0	0	0	0	0	1

3.398. QUERY RGB IN - RGB2 EDID MODE [QVX:EDMI1]

Hexadecimal	02h	41h	44h	5Ah	5Ah	3Bh	51h	56h	58h	3Ah
Character		A	D	Z	Z	;	Q	V	X	:
Hexadecimal	45h	44h	4Dh	49h	31h	03h				
Character	E	D	M	I	1					

■ Response (Callback)

In the period when the command can be accepted

Hexadecimal	02h	45h	44h	4Dh	49h	31h	3Dh	2Bh	*1	*3
Character		E	D	M	I	1	=	+	*2	*4
Hexadecimal	*5	*7	*9	03h						
Character	*6	*8	*10							

Acceptability

SECURITY	STANDBY	ECO STANDBY	NO SIGNAL	SHUTTER	FREEZE	TEST PATTERN	REMOTE2	P IN P	LENS HOME
✓	✓		✓	✓	✓	✓	✓	✓	✓

■ Parameters (*1,*2,*3,*4,*5,*6,*7,*8,*9,*10)

	DEFAULT					SCREEN FIT				
Hexadecimal	30h	30h	30h	30h	30h	30h	30h	30h	30h	31h
Character	0	0	0	0	0	0	0	0	0	1
	USER									
Hexadecimal	30h	30h	30h	31h	30h					
Character	0	0	0	1	0					

3.399. QUERY RGB IN - RGB2 EDID RESOLUTION [QVX:EDRS1]

Hexadecimal	02h	41h	44h	5Ah	5Ah	3Bh	51h	56h	58h	3Ah
Character		A	D	Z	Z	;	Q	V	X	:
Hexadecimal	45h	44h	52h	53h	31h	03h				
Character	E	D	R	S	1					

■ Response (Callback)

In the period when the command can be accepted

Hexadecimal	02h	45h	44h	52h	53h	31h	3Dh	2Bh	*1	*3
Character		E	D	R	S	1	=	+	*2	*4
Hexadecimal	*5	*7	*9	*11	*13	*15	*17	*19	*21	
Character	*6	*8	*10	*12	*14	*16	*18	*20	*22	

Acceptability

SECURITY	STANDBY	ECO STANDBY	NO SIGNAL	SHUTTER	FREEZE	TEST PATTERN	REMOTE2	P IN P	LENS HOME
✓	✓		✓	✓	✓	✓	✓	✓	✓

■ Parameters (*1,*2,*3,*4,*5,*6,*7,*8,...*11,*12,...,*21,*22)

1024x768p											
Hexadecimal	31h	30h	32h	34h	3Ah	30h	37h	36h	38h	3Ah	70h
Character	1	0	2	4	:	0	7	6	8	:	p
1280x720p											
Hexadecimal	31h	30h	32h	34h	3Ah	30h	37h	32h	30h	3Ah	70h
Character	1	2	8	0	:	0	7	2	0	:	p
1280x768p											
Hexadecimal	31h	30h	32h	34h	3Ah	30h	37h	36h	38h	3Ah	70h
Character	1	2	8	0	:	0	7	6	8	:	p
1280x800p											
Hexadecimal	31h	30h	32h	34h	3Ah	30h	38h	30h	30h	3Ah	70h
Character	1	2	8	0	:	0	8	0	0	:	p
1280x1024p											
Hexadecimal	31h	30h	32h	34h	3Ah	31h	30h	32h	34h	3Ah	70h
Character	1	2	8	0	:	1	0	2	4	:	p
1366x768p											
Hexadecimal	31h	33h	36h	36h	3Ah	30h	37h	36h	38h	3Ah	70h
Character	1	3	6	6	:	0	7	6	8	:	p
1400x1050p											
Hexadecimal	31h	34h	30h	30h	3Ah	31h	30h	35h	30h	3Ah	70h
Character	1	4	0	0	:	1	0	5	0	:	p
1440x900p											
Hexadecimal	31h	34h	34h	30h	3Ah	30h	39h	30h	30h	3Ah	70h
Character	1	4	4	0	:	0	9	0	0	:	p
1600x900p											
Hexadecimal	31h	36h	30h	30h	3Ah	30h	39h	30h	30h	3Ah	70h
Character	1	6	0	0	:	0	9	0	0	:	p
1600x1200p											
Hexadecimal	31h	36h	30h	30h	3Ah	31h	32h	30h	30h	3Ah	70h
Character	1	6	0	0	:	1	2	0	0	:	p
1680x1050p											
Hexadecimal	31h	36h	38h	30h	3Ah	31h	30h	35h	30h	3Ah	70h
Character	1	6	8	0	:	1	0	5	0	:	p
1920x1080p											
Hexadecimal	31h	39h	32h	30h	3Ah	31h	30h	38h	30h	3Ah	70h
Character	1	9	2	0	:	1	0	8	0	:	p
1920x1080i											
Hexadecimal	31h	39h	32h	30h	3Ah	30h	30h	38h	30h	3Ah	69h
Character	1	9	2	0	:	1	0	8	0	:	i
1920x1200p											
Hexadecimal	31h	39h	32h	30h	3Ah	31h	30h	30h	30h	3Ah	70h
Character	1	9	2	0	:	1	2	0	0	:	p

3.400. QUERY RGB IN - RGB2 EDID VERTICAL SCAN FREQUENCY [QVX:EDV1]

Hexadecimal	02h	41h	44h	5Ah	5Ah	3Bh	51h	56h	58h	3Ah
Character		A	D	Z	Z	;	Q	V	X	:
Hexadecimal	45h	44h	56h	49h	31h	03h				
Character	E	D	V	I	1					

■ Response (Callback)

In the period when the command can be accepted

Hexadecimal	02h	45h	44h	56h	49h	31h	3Dh	2Bh	*1	*3
Character		E	D	V	I	1	=	+	*2	*4
Hexadecimal	*5	*7	*9	03h						
Character	*6	*8	*10							

Acceptability

SECURITY	STANDBY	ECO STANDBY	NO SIGNAL	SHUTTER	FREEZE	TEST PATTERN	REMOTE2	P IN P	LENS HOME
✓	✓		✓	✓	✓	✓	✓	✓	✓

■ Parameters (*1,*2,*3,*4,*5,*6,*7,*8,*9,*10)

	60Hz					50Hz				
Hexadecimal	30h	36h	30h	30h	30h	30h	35h	30h	30h	30h
Character	0	6	0	0	0	0	5	0	0	0
	48Hz					30Hz				
Hexadecimal	30h	34h	38h	30h	30h	30h	33h	30h	30h	30h
Character	0	4	8	0	0	0	3	0	0	0
	25Hz					24Hz				
Hexadecimal	30h	32h	35h	30h	30h	30h	32h	34h	30h	30h
Character	0	2	5	0	0	0	2	4	0	0

3.401. QUERY DVI-D IN - EDID [QED]

Hexadecimal	02h	41h	44h	5Ah	5Ah	3Bh	51h	45h	44h	03h
Character		A	D	Z	Z	;	Q	E	D	

■ Response (Callback)

In the period when the command can be accepted

Hexadecimal	02h	*1	03h
Character		*2	

Acceptability

SECURITY	STANDBY	ECO STANDBY	NO SIGNAL	SHUTTER	FREEZE	TEST PATTERN	REMOTE2	P IN P	LENS HOME
✓	✓		✓	✓	✓	✓	✓	✓	✓

■ Parameters (*1,*2)

	EDID1	EDID2 (PC)	EDID3
Hexadecimal	31h	32h	33h
Character	1	2	3

3.402. QUERY DVI-D IN - SIGNAL LEVEL [QVX:DVII0]

Hexadecimal	02h	41h	44h	5Ah	5Ah	3Bh	51h	56h	58h	3Ah
Character		A	D	Z	Z	;	Q	V	X	:
Hexadecimal	44h	56h	49h	49h	30h	03h				
Character	D	V	I	I	0					

■ Response (Callback)

In the period when the command can be accepted

Hexadecimal	02h	44h	56h	49h	49h	30h	3Dh	2Bh
Character		D	V	I	I	0	=	+
Hexadecimal	*1	*3	*5	*7	*9	03h		
Character	*2	*4	*6	*8	*10			

Acceptability

SECURITY	STANDBY	ECO STANDBY	NO SIGNAL	SHUTTER	FREEZE	TEST PATTERN	REMOTE2	P IN P	LENS HOME
✓	✓		✓	✓	✓	✓	✓	✓	✓

■ Parameters (*1,*2,*3,*4,*5,*6,*7,*8,*9,*10)

	0-255:PC					16-235					AUTO				
Hexadecimal	30h	30h	30h	30h	30h	30h	30h	30h	30h	31h	30h	30h	30h	30h	32h
Character	0	0	0	0	0	0	0	0	0	1	0	0	0	0	2

3.403. QUERY DVI-D IN - EDID MODE [QVX:EDMI2]

Hexadecimal	02h	41h	44h	5Ah	5Ah	3Bh	51h	56h	58h	3Ah
Character		A	D	Z	Z	;	Q	V	X	:
Hexadecimal	45h	44h	4Dh	49h	32h	03h				
Character	E	D	M	I	2					

■ Response (Callback)

In the period when the command can be accepted

Hexadecimal	02h	45h	44h	4Dh	49h	32h	3Dh	2Bh	*1	*3
Character		E	D	M	I	2	=	+	*2	*4
Hexadecimal	*5	*7	*9	03h						
Character	*6	*8	*10							

Acceptability

SECURITY	STANDBY	ECO STANDBY	NO SIGNAL	SHUTTER	FREEZE	TEST PATTERN	REMOTE2	P IN P	LENS HOME
✓	✓		✓	✓	✓	✓	✓	✓	✓

■ Parameters(*1,*2,*3,*4,*5,*6,*7,*8,*9,*10)

		DEFAULT					SCREEN FIT				
Hexadecimal		30h	30h	30h	30h	30h	30h	30h	30h	30h	31h
Character		0	0	0	0	0	0	0	0	0	1
		USER									
Hexadecimal		30h	30h	30h	31h	30h					
Character		0	0	0	1	0					

3.404. QUERY DVI-D IN - EDID RESOLUTION [QVX:EDRS2]

Hexadecimal	02h	41h	44h	5Ah	5Ah	3Bh	51h	56h	58h	3Ah
Character		A	D	Z	Z	:	Q	V	X	:
Hexadecimal	45h	44h	52h	53h	32h	03h				
Character	E	D	R	S	2					

■ Response (Callback)

In the period when the command can be accepted

Hexadecimal	02h	45h	44h	52h	53h	32h	3Dh	2Bh	*1	*3
Character		E	D	R	S	2	=	+	*2	*4
Hexadecimal	*5	*7	*9	*11	*13	*15	*17	*19	*21	
Character	*6	*8	*10	*12	*14	*16	*18	*20	*22	

Acceptability

SECURITY	STANDBY	ECO STANDBY	NO SIGNAL	SHUTTER	FREEZE	TEST PATTERN	REMOTE2	P IN P	LENS HOME
✓	✓		✓	✓	✓	✓	✓	✓	✓

■ Parameters (*1,*2,*3,*4,*5,*6,*7,*8,...*11,*12,...,*21,*22)

1024x768p											
Hexadecimal	31h	30h	32h	34h	3Ah	30h	37h	36h	38h	3Ah	70h
Character	1	0	2	4	:	0	7	6	8	:	p
1280x720p											
Hexadecimal	31h	30h	32h	34h	3Ah	30h	37h	32h	30h	3Ah	70h
Character	1	2	8	0	:	0	7	2	0	:	p
1280x768p											
Hexadecimal	31h	30h	32h	34h	3Ah	30h	37h	36h	38h	3Ah	70h
Character	1	2	8	0	:	0	7	6	8	:	p
1280x800p											
Hexadecimal	31h	30h	32h	34h	3Ah	30h	38h	30h	30h	3Ah	70h
Character	1	2	8	0	:	0	8	0	0	:	p
1280x1024p											
Hexadecimal	31h	30h	32h	34h	3Ah	31h	30h	32h	34h	3Ah	70h
Character	1	2	8	0	:	1	0	2	4	:	p
1366x768p											
Hexadecimal	31h	33h	36h	36h	3Ah	30h	37h	36h	38h	3Ah	70h
Character	1	3	6	6	:	0	7	6	8	:	p
1400x1050p											
Hexadecimal	31h	34h	30h	30h	3Ah	31h	30h	35h	30h	3Ah	70h
Character	1	4	0	0	:	1	0	5	0	:	p
1440x900p											
Hexadecimal	31h	34h	34h	30h	3Ah	30h	39h	30h	30h	3Ah	70h
Character	1	4	4	0	:	0	9	0	0	:	p
1600x900p											
Hexadecimal	31h	36h	30h	30h	3Ah	30h	39h	30h	30h	3Ah	70h
Character	1	6	0	0	:	0	9	0	0	:	p
1600x1200p											
Hexadecimal	31h	36h	30h	30h	3Ah	31h	32h	30h	30h	3Ah	70h
Character	1	6	0	0	:	1	2	0	0	:	p
1680x1050p											
Hexadecimal	31h	36h	38h	30h	3Ah	31h	30h	35h	30h	3Ah	70h
Character	1	6	8	0	:	1	0	5	0	:	p
1920x1080p											
Hexadecimal	31h	39h	32h	30h	3Ah	31h	30h	38h	30h	3Ah	70h
Character	1	9	2	0	:	1	0	8	0	:	p
1920x1080i											
Hexadecimal	31h	39h	32h	30h	3Ah	30h	30h	38h	30h	3Ah	69h
Character	1	9	2	0	:	1	0	8	0	:	i
1920x1200p											
Hexadecimal	31h	39h	32h	30h	3Ah	31h	30h	30h	30h	3Ah	70h
Character	1	9	2	0	:	1	2	0	0	:	p

3.405. QUERY DVI-D IN - EDID VERTICAL SCAN FREQUENCY [QVX:EDVI2]

Hexadecimal	02h	41h	44h	5Ah	5Ah	3Bh	51h	56h	58h	3Ah
Character		A	D	Z	Z	;	Q	V	X	:
Hexadecimal	45h	44h	56h	49h	32h	03h				
Character	E	D	V	I	2					

■ Response (Callback)

In the period when the command can be accepted

Hexadecimal	02h	45h	44h	56h	49h	32h	3Dh	2Bh	*1	*3
Character		E	D	V	I	2	=	+	*2	*4
Hexadecimal	*5	*7	*9	03h						
Character	*6	*8	*10							

Acceptability

SECURITY	STANDBY	ECO STANDBY	NO SIGNAL	SHUTTER	FREEZE	TEST PATTERN	REMOTE2	P IN P	LENS HOME
✓	✓		✓	✓	✓	✓	✓	✓	✓

■ Parameters (*1,*2,*3,*4,*5,*6,*7,*8,*9,*10)

	60Hz					50Hz				
Hexadecimal	30h	36h	30h	30h	30h	30h	35h	30h	30h	30h
Character	0	6	0	0	0	0	5	0	0	0
	48Hz					30Hz				
Hexadecimal	30h	34h	38h	30h	30h	30h	33h	30h	30h	30h
Character	0	4	8	0	0	0	3	0	0	0
	25Hz					24Hz				
Hexadecimal	30h	32h	35h	30h	30h	30h	32h	34h	30h	30h
Character	0	2	5	0	0	0	2	4	0	0

3.406. QUERY HDMI IN - SIGNAL LEVEL [QVX:HSLI0]

Hexadecimal	02h	41h	44h	5Ah	5Ah	3Bh	51h	56h	48h	3Ah
Character		A	D	Z	Z	;	Q	V	X	:
Hexadecimal	48h	53h	4Ch	49h	30h	03h				
Character	H	S	L	I	0					

■ Response (Callback)

In the period when the command can be accepted

Hexadecimal	02h	48h	53h	4Ch	49h	30h	3Dh	2Bh
Character		H	S	L	I	0	=	+
Hexadecimal	*1	*3	*5	*7	*9	03h		
Character	*2	*4	*6	*8	*10			

Acceptability

SECURITY	STANDBY	ECO STANDBY	NO SIGNAL	SHUTTER	FREEZE	TEST PATTERN	REMOTE2	P IN P	LENS HOME
✓	✓		✓	✓	✓	✓	✓	✓	✓

■ Parameters (*1,*2,*3,*4,*5,*6,*7,*8,*9,*10)

	0-1023					64-940					AUTO				
Hexadecimal	30h	30h	30h	30h	30h	30h	30h	30h	30h	31h	30h	30h	30h	30h	32h
Character	0	0	0	0	0	0	0	0	0	1	0	0	0	0	2

3.407. QUERY HDMI IN - EDID MODE [QVX:EDMI3]

Hexadecimal	02h	41h	44h	5Ah	5Ah	3Bh	51h	56h	58h	3Ah
Character		A	D	Z	Z	;	Q	V	X	:
Hexadecimal	45h	44h	4Dh	49h	33h	03h				
Character	E	D	M	I	3					

■ Response (Callback)

In the period when the command can be accepted

Hexadecimal	02h	45h	44h	4Dh	49h	33h	3Dh	2Bh	*1	*3
Character		E	D	M	I	3	=	+	*2	*4
Hexadecimal	*5	*7	*9	03h						
Character	*6	*8	*10							

Acceptability

SECURITY	STANDBY	ECO STANDBY	NO SIGNAL	SHUTTER	FREEZE	TEST PATTERN	REMOTE2	P IN P	LENS HOME
✓	✓		✓	✓	✓	✓	✓	✓	✓

■ Parameters (*1,*2,*3,*4,*5,*6,*7,*8,*9,*10)

	DEFAULT					SCREEN FIT				
Hexadecimal	30h	30h	30h	30h	30h	30h	30h	30h	30h	31h
Character	0	0	0	0	0	0	0	0	0	1
	USER									
Hexadecimal	30h	30h	30h	31h	30h					
Character	0	0	0	1	0					

3.408. QUERY HDMI IN - EDID RESOLUTION [QVX:EDRS3]

Hexadecimal	02h	41h	44h	5Ah	5Ah	3Bh	51h	56h	58h	3Ah
Character		A	D	Z	Z	;	Q	V	X	:
Hexadecimal	45h	44h	52h	53h	33h	03h				
Character	E	D	R	S	3					

■ Response (Callback)

In the period when the command can be accepted

Hexadecimal	02h	45h	44h	52h	53h	33h	3Dh	2Bh	*1	*3
Character		E	D	R	S	3	=	+	*2	*4
Hexadecimal	*5	*7	*9	*11	*13	*15	*17	*19	*21	
Character	*6	*8	*10	*12	*14	*16	*18	*20	*22	

Acceptability

SECURITY	STANDBY	ECO STANDBY	NO SIGNAL	SHUTTER	FREEZE	TEST PATTERN	REMOTE2	P IN P	LENS HOME
✓	✓		✓	✓	✓	✓	✓	✓	✓

■ Parameters (*1,*2,*3,*4,*5,*6,*7,*8,...*11,*12,...,*21,*22)

1024x768p											
Hexadecimal	31h	30h	32h	34h	3Ah	30h	37h	36h	38h	3Ah	70h
Character	1	0	2	4	:	0	7	6	8	:	p
1280x720p											
Hexadecimal	31h	30h	32h	34h	3Ah	30h	37h	32h	30h	3Ah	70h
Character	1	2	8	0	:	0	7	2	0	:	p
1280x768p											
Hexadecimal	31h	30h	32h	34h	3Ah	30h	37h	36h	38h	3Ah	70h
Character	1	2	8	0	:	0	7	6	8	:	p
1280x800p											
Hexadecimal	31h	30h	32h	34h	3Ah	30h	38h	30h	30h	3Ah	70h
Character	1	2	8	0	:	0	8	0	0	:	p
1280x1024p											
Hexadecimal	31h	30h	32h	34h	3Ah	31h	30h	32h	34h	3Ah	70h
Character	1	2	8	0	:	1	0	2	4	:	p
1366x768p											
Hexadecimal	31h	33h	36h	36h	3Ah	30h	37h	36h	38h	3Ah	70h
Character	1	3	6	6	:	0	7	6	8	:	p
1400x1050p											
Hexadecimal	31h	34h	30h	30h	3Ah	31h	30h	35h	30h	3Ah	70h
Character	1	4	0	0	:	1	0	5	0	:	p
1440x900p											
Hexadecimal	31h	34h	34h	30h	3Ah	30h	39h	30h	30h	3Ah	70h
Character	1	4	4	0	:	0	9	0	0	:	p
1600x900p											
Hexadecimal	31h	36h	30h	30h	3Ah	30h	39h	30h	30h	3Ah	70h
Character	1	6	0	0	:	0	9	0	0	:	p
1600x1200p											
Hexadecimal	31h	36h	30h	30h	3Ah	31h	32h	30h	30h	3Ah	70h
Character	1	6	0	0	:	1	2	0	0	:	p
1680x1050p											
Hexadecimal	31h	36h	38h	30h	3Ah	31h	30h	35h	30h	3Ah	70h
Character	1	6	8	0	:	1	0	5	0	:	p
1920x1080p											
Hexadecimal	31h	39h	32h	30h	3Ah	31h	30h	38h	30h	3Ah	70h
Character	1	9	2	0	:	1	0	8	0	:	p
1920x1080i											
Hexadecimal	31h	39h	32h	30h	3Ah	30h	38h	30h	30h	3Ah	69h
Character	1	9	2	0	:	1	0	8	0	:	i
1920x1200p											
Hexadecimal	31h	39h	32h	30h	3Ah	31h	30h	30h	30h	3Ah	70h
Character	1	9	2	0	:	1	2	0	0	:	p

3.409. QUERY HDMI IN - EDID VERTICAL SCAN FREQUENCY [QVX:EDVI3]

Hexadecimal	02h	41h	44h	5Ah	5Ah	3Bh	51h	56h	58h	3Ah
Character		A	D	Z	Z	;	Q	V	X	:
Hexadecimal	45h	44h	56h	49h	33h	03h				
Character	E	D	V	I	3					

■ Response (Callback)

In the period when the command can be accepted

Hexadecimal	02h	45h	44h	56h	49h	32h	3Dh	2Bh	*1	*3
Character		E	D	V	I	2	=	+	*2	*4
Hexadecimal	*5	*7	*9	03h						
Character	*6	*8	*10							

Acceptability

SECURITY	STANDBY	ECO STANDBY	NO SIGNAL	SHUTTER	FREEZE	TEST PATTERN	REMOTE2	P IN P	LENS HOME
✓	✓		✓	✓	✓	✓	✓	✓	✓

■ Parameters (*1,*2,*3,*4,*5,*6,*7,*8,*9,*10)

	60Hz					50Hz				
Hexadecimal	30h	36h	30h	30h	30h	30h	35h	30h	30h	30h
Character	0	6	0	0	0	0	5	0	0	0
	48Hz					30Hz				
Hexadecimal	30h	34h	38h	30h	30h	30h	33h	30h	30h	30h
Character	0	4	8	0	0	0	3	0	0	0
	25Hz					24Hz				
Hexadecimal	30h	32h	35h	30h	30h	30h	32h	34h	30h	30h
Character	0	2	5	0	0	0	2	4	0	0

3.410. QUERY DIGITAL LINK - SIGNAL LEVEL [QVX:DKLI1]

Hexadecimal	02h	41h	44h	5Ah	5Ah	3Bh	51h	56h	48h	3Ah
Character		A	D	Z	Z	;	Q	V	X	:
Hexadecimal	44h	4Bh	4Ch	49h	31h	03h				
Character	D	K	L	I	1					

■ Response (Callback)

In the period when the command can be accepted

Hexadecimal	02h	44h	4Bh	4Ch	49h	31h	3Dh	2Bh
Character		D	K	L	I	1	=	+
Hexadecimal	*1	*3	*5	*7	*9	03h		
Character	*2	*4	*6	*8	*10			

Acceptability

SECURITY	STANDBY	ECO STANDBY	NO SIGNAL	SHUTTER	FREEZE	TEST PATTERN	REMOTE2	P IN P	LENS HOME
✓	✓		✓	✓	✓	✓	✓	✓	✓

■ Parameters (*1,*2,*3,*4,*5,*6,*7,*8,*9,*10)

	AUTO					0-1023					64-940				
Hexadecimal	30h	30h	30h	30h	30h	30h	30h	30h	30h	31h	30h	30h	30h	30h	32h
Character	0	0	0	0	0	0	0	0	0	1	0	0	0	0	2

3.411. QUERY DIGITAL LINK - EDID MODE [QVX:EDMI4]

Hexadecimal	02h	41h	44h	5Ah	5Ah	3Bh	51h	56h	58h	3Ah
Character		A	D	Z	Z	;	Q	V	X	:
Hexadecimal	45h	44h	4Dh	49h	34h	03h				
Character	E	D	M	I	4					

■ Response (Callback)

In the period when the command can be accepted

Hexadecimal	02h	45h	44h	4Dh	49h	34h	3Dh	2Bh	*1	*3
Character		E	D	M	I	4	=	+	*2	*4
Hexadecimal	*5	*7	*9	03h						
Character	*6	*8	*10							

Acceptability

SECURITY	STANDBY	ECO STANDBY	NO SIGNAL	SHUTTER	FREEZE	TEST PATTERN	REMOTE2	P IN P	LENS HOME
✓	✓		✓	✓	✓	✓	✓	✓	✓

■ Parameters (*1,*2,*3,*4,*5,*6,*7,*8,*9,*10)

	DEFAULT					SCREEN FIT				
Hexadecimal	30h	30h	30h	30h	30h	30h	30h	30h	30h	31h
Character	0	0	0	0	0	0	0	0	0	1
	USER									
Hexadecimal	30h	30h	30h	31h	30h					
Character	0	0	0	1	0					

3.412. QUERY DIGITAL LINK - EDID RESOLUTION [QVX:EDRS4]

Hexadecimal	02h	41h	44h	5Ah	5Ah	3Bh	51h	56h	58h	3Ah
Character		A	D	Z	Z	;	Q	V	X	:
Hexadecimal	45h	44h	52h	53h	34h	03h				
Character	E	D	R	S	4					

■ Response (Callback)

In the period when the command can be accepted

Hexadecimal	02h	45h	44h	52h	53h	34h	3Dh	2Bh	*1	*3
Character		E	D	R	S	4	=	+	*2	*4
Hexadecimal	*5	*7	*9	*11	*13	*15	*17	*19	*21	
Character	*6	*8	*10	*12	*14	*16	*18	*20	*22	

Acceptability

SECURITY	STANDBY	ECO STANDBY	NO SIGNAL	SHUTTER	FREEZE	TEST PATTERN	REMOTE2	P IN P	LENS HOME
✓	✓		✓	✓	✓	✓	✓	✓	✓

■ Parameters (*1,*2,*3,*4,*5,*6,*7,*8,...*11,*12,...,*21,*22)

1024x768p											
Hexadecimal	31h	30h	32h	34h	3Ah	30h	37h	36h	38h	3Ah	70h
Character	1	0	2	4	:	0	7	6	8	:	p
1280x720p											
Hexadecimal	31h	30h	32h	34h	3Ah	30h	37h	32h	30h	3Ah	70h
Character	1	2	8	0	:	0	7	2	0	:	p
1280x768p											
Hexadecimal	31h	30h	32h	34h	3Ah	30h	37h	36h	38h	3Ah	70h
Character	1	2	8	0	:	0	7	6	8	:	p
1280x800p											
Hexadecimal	31h	30h	32h	34h	3Ah	30h	38h	30h	30h	3Ah	70h
Character	1	2	8	0	:	0	8	0	0	:	p
1280x1024p											
Hexadecimal	31h	30h	32h	34h	3Ah	31h	30h	32h	34h	3Ah	70h
Character	1	2	8	0	:	1	0	2	4	:	p
1366x768p											
Hexadecimal	31h	33h	36h	36h	3Ah	30h	37h	36h	38h	3Ah	70h
Character	1	3	6	6	:	0	7	6	8	:	p
1400x1050p											
Hexadecimal	31h	34h	30h	30h	3Ah	31h	30h	35h	30h	3Ah	70h
Character	1	4	0	0	:	1	0	5	0	:	p
1440x900p											
Hexadecimal	31h	34h	34h	30h	3Ah	30h	39h	30h	30h	3Ah	70h
Character	1	4	4	0	:	0	9	0	0	:	p
1600x900p											
Hexadecimal	31h	36h	30h	30h	3Ah	30h	39h	30h	30h	3Ah	70h
Character	1	6	0	0	:	0	9	0	0	:	p
1600x1200p											
Hexadecimal	31h	36h	30h	30h	3Ah	31h	32h	30h	30h	3Ah	70h
Character	1	6	0	0	:	1	2	0	0	:	p
1680x1050p											
Hexadecimal	31h	36h	38h	30h	3Ah	31h	30h	35h	30h	3Ah	70h
Character	1	6	8	0	:	1	0	5	0	:	p
1920x1080p											
Hexadecimal	31h	39h	32h	30h	3Ah	31h	30h	38h	30h	3Ah	70h
Character	1	9	2	0	:	1	0	8	0	:	p
1920x1080i											
Hexadecimal	31h	39h	32h	30h	3Ah	30h	30h	38h	30h	3Ah	69h
Character	1	9	2	0	:	1	0	8	0	:	i
1920x1200p											
Hexadecimal	31h	39h	32h	30h	3Ah	31h	30h	30h	30h	3Ah	70h
Character	1	9	2	0	:	1	2	0	0	:	p

3.413. QUERY DIGITAL LINK - EDID VERTICAL SCAN FREQUENCY [QVX:EDVI4]

Hexadecimal	02h	41h	44h	5Ah	5Ah	3Bh	51h	56h	58h	3Ah
Character		A	D	Z	Z	:	Q	V	X	:
Hexadecimal	45h	44h	56h	49h	34h	03h				
Character	E	D	V	I	4					

■ Response (Callback)

In the period when the command can be accepted

Hexadecimal	02h	45h	44h	56h	49h	34h	3Dh	2Bh	*1	*3
Character		E	D	V	I	4	=	+	*2	*4
Hexadecimal	*5	*7	*9	03h						
Character	*6	*8	*10							

Acceptability

SECURITY	STANDBY	ECO STANDBY	NO SIGNAL	SHUTTER	FREEZE	TEST PATTERN	REMOTE2	P IN P	LENS HOME
✓	✓		✓	✓	✓	✓	✓	✓	✓

■ Parameters (*1,*2,*3,*4,*5,*6,*7,*8,*9,*10)

60Hz						50Hz				
Hexadecimal	30h	36h	30h	30h	30h	30h	35h	30h	30h	30h
Character	0	6	0	0	0	0	5	0	0	0
48Hz						30Hz				
Hexadecimal	30h	34h	38h	30h	30h	30h	33h	30h	30h	30h
Character	0	4	8	0	0	0	3	0	0	0

	25Hz					24Hz				
Hexadecimal	30h	32h	35h	30h	30h	30h	32h	34h	30h	30h
Character	0	2	5	0	0	0	2	4	0	0

3.414. QUERY SDI IN – SDI LEVEL [QED:SDI-LEVEL]

Hexadecimal	02h	41h	44h	5Ah	5Ah	3Bh	51h	45h	44h	3Ah
Character		A	D	Z	Z	;	Q	E	D	:
Hexadecimal	53h	44h	49h	2Dh	4Ch	45h	56h	45h	4Ch	03h
Character	S	D	I	-	L	E	V	E	L	

■ Response (Callback)

In the period when the command can be accepted

Hexadecimal	02h	*1	03h
Character		*2	

Acceptability

SECURITY	STANDBY	ECO STANDBY	NO SIGNAL	SHUTTER	FREEZE	TEST PATTERN	REMOTE2	P IN P	LENS HOME
✓	✓		✓	✓	✓	✓	✓	✓	✓

■ Parameters (*1,*2)

	64-940	4-1019
Hexadecimal	30h	31h
Character	0	1

■ Note:

· Only for DZ780(FDZ88C)

3.415. QUERY SDI IN – SDI SIGNAL LEVEL [QVX:SSL11]

Hexadecimal	02h	41h	44h	5Ah	5Ah	3Bh	51h	56h	58h	3Ah
Character		A	D	Z	Z	;	Q	V	X	:
Hexadecimal	53h	53h	4C	49h	31h	03h				
Character	S	S	L	I	1					

■ Response (Callback)

In the period when the command can be accepted

Hexadecimal	02h	53h	53h	4C	49h	31h	3Dh	2Bh	*1	*3
Character		S	S	L	I	1	=	+	*2	*4
Hexadecimal	*5	*7	*9	03h						
Character	*6	*8	*10							

Acceptability

SECURITY	STANDBY	ECO STANDBY	NO SIGNAL	SHUTTER	FREEZE	TEST PATTERN	REMOTE2	P IN P	LENS HOME
✓	✓		✓	✓	✓	✓	✓	✓	✓

■ Parameters (*1,*2,*3,*4,*5,*6,*7,*8,*9,*10)

	64-940					4-1019				
Hexadecimal	30h	30h	30h	30h	30h	30h	30h	30h	30h	31h
Character	0	0	0	0	0	0	0	0	0	1

■ Note:

· Only for DZ780(FDZ88C)

3.416. QUERY SDI IN - BIT DEPTH [QVX:SBT11]

Hexadecimal	02h	41h	44h	5Ah	5Ah	3Bh	51h	56h	58h	3Ah
Character		A	D	Z	Z	;	Q	V	X	:
Hexadecimal	53h	42h	54h	49h	31h	03h				
Character	S	B	T	I	1					

■ Response (Callback)

In the period when the command can be accepted

Hexadecimal	02h	53h	42h	54h	49h	31h	3Dh	2Bh	*1	*3
Character		S	B	T	I	1	=	+	*2	*4
Hexadecimal	*5	*7	*9	03h						
Character	*6	*8	*10							

Acceptability

SECURITY	STANDBY	ECO STANDBY	NO SIGNAL	SHUTTER	FREEZE	TEST PATTERN	REMOTE2	P IN P	LENS HOME
✓			✓	✓	✓	✓	✓	✓	✓

■ Parameters (*1,*2,*3,*4,*5,*6,*7,*8,*9,*10)

	AUTO					12-bit				
Hexadecimal	30h	30h	30h	30h	30h	30h	30h	30h	30h	31h
Character	0	0	0	0	0	0	0	0	0	1
	10-bit									
Hexadecimal	30h	30h	30h	30h	32h					
Character	0	0	0	0	2					

■ Note:

· Only for DZ780(FDZ88C)

3.417. QUERY SDI IN - 3G-SDI MAPPING [QVX:SGMI1]

Hexadecimal	02h	41h	44h	5Ah	5Ah	3Bh	51h	56h	58h	3Ah
Character		A	D	Z	Z	;	Q	V	X	:
Hexadecimal	53h	47h	4Dh	49h	31h	03h				
Character	S	G	M	I	1					

■ Response (Callback)

In the period when the command can be accepted

Hexadecimal	02h	53h	47h	4Dh	49h	31h	3Dh	2Bh	*1	*3
Character		S	G	M	I	1	=	+	*2	*4
Hexadecimal	*5	*7	*9	03h						
Character	*6	*8	*10							

Acceptability

SECURITY	STANDBY	ECO STANDBY	NO SIGNAL	SHUTTER	FREEZE	TEST PATTERN	REMOTE2	P IN P	LENS HOME
✓			✓	✓	✓	✓	✓	✓	✓

■ Parameters (*1,*2,*3,*4,*5,*6,*7,*8,*9,*10)

	AUTO					LEVEL A				
Hexadecimal	30h	30h	30h	30h	30h	30h	30h	30h	30h	31h
Character	0	0	0	0	0	0	0	0	0	1
	LEVEL B									
Hexadecimal	30h	30h	30h	30h	32h					
Character	0	0	0	0	2					

■ Note:

·IT IS ONLY EFFECTIVE FOR DZ780(FDZ88C), OTHER MODELS RETURN ER401.

3.418. QUERY ON-SCREEN DISPLAY - OSD POSITION [QDP]

Hexadecimal	02h	41h	44h	5Ah	5Ah	3Bh	51h	44h	50h	03h
Character		A	D	Z	Z	;	Q	D	P	

■ Response (Callback)

In the period when the command can be accepted

Hexadecimal	02h	*1	03h
Character		*2	

Acceptability

SECURITY	STANDBY	ECO STANDBY	NO SIGNAL	SHUTTER	FREEZE	TEST PATTERN	REMOTE2	P IN P	LENS HOME
✓	✓		✓	✓	✓	✓	✓	✓	✓

■ Parameters (*1,*2)

	Upper left	Center left	Bottom left	Top center	Center	Bottom center
Hexadecimal	31h	32h	33h	34h	35h	36h
Character	1	2	3	4	5	6
	Upper right	Center right	Bottom right			
Hexadecimal	37h	38h	39h			
Character	7	8	9			

3.419. QUERY ON-SCREEN DISPLAY - OSD DESIGN [QOD]

Hexadecimal	02h	41h	44h	5Ah	5Ah	3Bh	51h	4Fh	44h	03h
Character		A	D	Z	Z	;	Q	O	D	

■ Response (Callback)

In the period when the command can be accepted

Hexadecimal	02h	*1	03h
Character		*2	

Acceptability

SECURITY	STANDBY	ECO STANDBY	NO SIGNAL	SHUTTER	FREEZE	TEST PATTERN	REMOTE2	P IN P	LENS HOME
✓	✓		✓	✓	✓	✓	✓	✓	✓

■ Parameters (*1,*2)

	1	2	3	4	5	6
Hexadecimal	30h	31h	32h	33h	34h	35h
Character	0	1	2	3	4	5

3.420. QUERY ON-SCREEN DISPLAY - OSD MEMORY [QVX:OMYI0]

Hexadecimal	02h	41h	44h	5Ah	5Ah	3Bh	51h	56h	58h	3Ah
Character		A	D	Z	Z	;	Q	V	X	:
Hexadecimal	4Fh	4Dh	59h	49h	30h	03h				
Character	O	M	Y	I	0					

■ Response (Callback)

In the period when the command can be accepted

Hexadecimal	02h	4Fh	4Dh	59h	49h	30h	3Dh	2Bh	*1	*3
Character		O	M	Y	I	0	=	+	*2	*4
Hexadecimal	*5	*7	*9	03h						
Character	*6	*8	*10							

Acceptability

SECURITY	STANDBY	ECO STANDBY	NO SIGNAL	SHUTTER	FREEZE	TEST PATTERN	REMOTE2	P IN P	LENS HOME
✓	✓		✓	✓	✓	✓	✓	✓	✓

■ Parameters (*1,*2,*3,*4,*5,*6,*7,*8,*9,*10)

	OFF					ON				
Hexadecimal	30h	30h	30h	30h	30h	30h	30h	30h	30h	31h
Character	0	0	0	0	0	0	0	0	0	1

3.421. QUERY ON-SCREEN DISPLAY - INPUT GUIDE [QDI]

Hexadecimal	02h	41h	44h	5Ah	5Ah	3Bh	51h	44h	49h	03h
Character		A	D	Z	Z	;	Q	D	I	

■ Response (Callback)

In the period when the command can be accepted

Hexadecimal	02h	*1	03h
Character		*2	

Acceptability

SECURITY	STANDBY	ECO STANDBY	NO SIGNAL	SHUTTER	FREEZE	TEST PATTERN	REMOTE2	P IN P	LENS HOME
✓	✓		✓	✓	✓	✓	✓	✓	✓

■ Parameters (*1,*2)

	OFF	ON
Hexadecimal	30h	31h
Character	0	1

3.422. QUERY ON-SCREEN DISPLAY - WARNING MESSAGE [QVX:WMDI0]

Hexadecimal	02h	41h	44h	5Ah	5Ah	3Bh	51h	56h	58h	3Ah
Character		A	D	Z	Z	;	Q	V	X	:
Hexadecimal	57h	4Dh	44h	49h	30h	03h				
Character	W	M	D	I	0					

■ Response (Callback)

In the period when the command can be accepted

Hexadecimal	02h	57h	4Dh	44h	49h	30h	3Dh	2Bh	*1	*3
Character		W	M	D	I	0	=	+	*2	*4
Hexadecimal	*5	*7	*9	03h						
Character	*6	*8	*10							

Acceptability

SECURITY	STANDBY	ECO STANDBY	NO SIGNAL	SHUTTER	FREEZE	TEST PATTERN	REMOTE2	P IN P	LENS HOME
✓	✓		✓	✓	✓	✓	✓	✓	✓

■ Parameters (*1,*2,*3,*4,*5,*6,*7,*8,*9,*10)

	OFF					ON				
Hexadecimal	30h	30h	30h	30h	30h	30h	30h	30h	30h	31h
Character	0	0	0	0	0	0	0	0	0	1

3.423. CLOSED CAPTION SETTING [QCC]

Hexadecimal	02h	41h	44h	5Ah	5Ah	3Bh	51h	43h	43h	03h
Character		A	D	Z	Z	;	Q	C	C	

■ Response (Callback)

In the period when the command can be accepted

Hexadecimal	02h	*1	03h
Character		*2	

Acceptability

SECURITY	STANDBY	ECO STANDBY	NO SIGNAL	SHUTTER	FREEZE	TEST PATTERN	REMOTE2	P IN P	LENS HOME
✓				✓	✓	✓	✓	✓	✓

■ Parameters (*1,*2)

	OFF	CC1	CC2	CC3	CC4
Hexadecimal	30h	31h	32h	33h	34h
Character	0	1	2	3	4

3.424. QUERY BACK COLOR [QBC]

Hexadecimal	02h	41h	44h	5Ah	5Ah	3Bh	51h	42h	43h	03h
Character		A	D	Z	Z	;	Q	B	C	

■ Response (Callback)

In the period when the command can be accepted

Hexadecimal	02h	*1	03h
Character		*2	

Acceptability

SECURITY	STANDBY	ECO STANDBY	NO SIGNAL	SHUTTER	FREEZE	TEST PATTERN	REMOTE2	P IN P	LENS HOME
✓			✓	✓	✓	✓	✓	✓	✓

■ Parameters (*1,*2)

	BLUE	BLACK	USER LOGO	DEFAULT LOGO
Hexadecimal	30h	31h	32h	33h
Character	0	1	2	3

3.425. QUERY STARTUP LOGO [QLO]

Hexadecimal	02h	41h	44h	5Ah	5Ah	3Bh	51h	4Ch	4Fh	03h
Character		A	D	Z	Z	;	Q	L	O	

■ Response (Callback)

In the period when the command can be accepted

Hexadecimal	02h	*1	03h
Character		*2	

Acceptability

SECURITY	STANDBY	ECO STANDBY	NO SIGNAL	SHUTTER	FREEZE	TEST PATTERN	REMOTE2	P IN P	LENS HOME
✓	✓		✓	✓	✓	✓	✓	✓	✓

Parameters (*1,*2)

	NONE	USER LOGO	DEFAULT LOGO
Hexadecimal	30h	31h	32h
Character	0	1	2

3.426. QUERY UNIFORMITY - PC CORRECTION [QVX:UFMI1]

Hexadecimal	02h	41h	44h	5Ah	5Ah	3Bh	51h	56h	58h	3Ah
Character		A	D	Z	Z	;	Q	V	X	:
Hexadecimal	55h	46h	4Dh	49h	31h	03h				
Character	U	F	M	I	1					

■ Response (Callback)

In the period when the command can be accepted

Hexadecimal	02h	55h	46h	4Dh	49h	31h	3Dh	2Bh	*1	*3
Character		U	F	M	I	1	=	+	*2	*4
Hexadecimal	*5	*7	*9	03h						
Character	*6	*8	*10							

Acceptability

SECURITY	STANDBY	ECO STANDBY	NO SIGNAL	SHUTTER	FREEZE	TEST PATTERN	REMOTE2	P IN P	LENS HOME
✓			✓	✓	✓	✓	✓	✓	✓

■ Parameters (*1,*2,*3,*4,*5,*6,*7,*8,*9,*10)

	OFF					ON				
Hexadecimal	30h	30h	30h	30h	30h	30h	30h	30h	30h	31h
Character	0	0	0	0	0	0	0	0	0	1

■ Note:

· To use this function, an optional upgrade kit (activated) is required.

3.427. QUERY SHUTTER SETTING - FADE IN [QVX:SEFS1]

Hexadecimal	02h	41h	44h	5Ah	5Ah	3Bh	51h	56h	58h	3Ah
Character		A	D	Z	Z	;	Q	V	X	:
Hexadecimal	53h	45h	46h	53h	31h	03h				
Character	S	E	F	S	1					

■ Response (Callback)

In the period when the command can be accepted

Hexadecimal	02h	53h	45h	46h	53h	31h	3Dh	*1	*3
Character		S	E	F	S	1	=	*2	*4
Hexadecimal	*5	*7	03h						
Character	*6	*8							

Acceptability

SECURITY	STANDBY	ECO STANDBY	NO SIGNAL	SHUTTER	FREEZE	TEST PATTERN	REMOTE2	P IN P	LENS HOME
✓	✓		✓	✓	✓	✓	✓	✓	✓

Parameters (*1,*2,*3,*4,*5,*6,*7,*8)

	OFF (0.0 s)			0.5 s			3.5 s			4.0 s		
Hexadecimal	30h	2Eh	30h	30h	2Eh	35h	33h	2Eh	35h	34h	2Eh	30h
Character	0	.	0	0	.	5	3	.	5	4	.	0
	5.0 s			7.0 s			10.0 s					
Hexadecimal	35h	2Eh	30h	37h	2Eh	30h	31h	30h	2Eh	30h		
Character	5	.	0	7	.	0	1	0	.	0		

3.428. QUERY SHUTTER SETTING - FADE OUT [QVX:SEFS2]

Hexadecimal	02h	41h	44h	5Ah	5Ah	3Bh	51h	56h	58h	3Ah
Character		A	D	Z	Z	;	Q	V	X	:
Hexadecimal	53h	45h	46h	53h	32h	03h				
Character	S	E	F	S	2					

■ Response (Callback)

In the period when the command can be accepted

Hexadecimal	02h	53h	45h	46h	53h	32h	3Dh	*1	*3
Character		S	E	F	S	2	=	*2	*4
Hexadecimal	*5	*7	03h						
Character	*6	*8							

Acceptability

SECURITY	STANDBY	ECO STANDBY	NO SIGNAL	SHUTTER	FREEZE	TEST PATTERN	REMOTE2	P IN P	LENS HOME
✓	✓		✓	✓	✓	✓	✓	✓	✓

■ Parameters (*1,*2,*3,*4,*5,*6,*7,*8)

	OFF (0.0 s)			0.5 s			3.5 s			4.0 s		
Hexadecimal	30h	2Eh	30h	30h	2Eh	35h	33h	2Eh	35h	34h	2Eh	30h
Character	0	.	0	0	.	5	3	.	5	4	.	0
	5.0 s			7.0 s			10.0 s					
Hexadecimal	35h	2Eh	30h	37h	2Eh	30h	31h	30h	2Eh	30h		
Character	5	.	0	7	.	0	1	0	.	0		

3.429. QUERY SHUTTER SETTING - STARTUP [QVX:SEFI3]

Hexadecimal	02h	41h	44h	5Ah	5Ah	3Bh	51h	56h	58h	3Ah
Character		A	D	Z	Z	;	Q	V	X	:
Hexadecimal	53h	45h	46h	49h	33h	03h				
Character	S	E	F	I	3					

■ Response (Callback)

In the period when the command can be accepted

Hexadecimal	02h	53h	45h	46h	49h	33h	3Dh	2Bh	*1	*3
Character		S	E	F	I	3	=	+	*2	*4
Hexadecimal	*5	*7	*9	03h						
Character	*6	*8	*10							

Acceptability

SECURITY	STANDBY	ECO STANDBY	NO SIGNAL	SHUTTER	FREEZE	TEST PATTERN	REMOTE2	P IN P	LENS HOME
✓	✓		✓	✓	✓	✓	✓	✓	✓

■ Parameters (*1,*2,*3,*4,*5,*6,*7,*8,*9,*10)

	OPEN					CLOSE				
Hexadecimal	30h	30h	30h	30h	30h	30h	30h	30h	30h	31h
Character	0	0	0	0	0	0	0	0	0	1

3.430. QUERY SHUTTER SETTING - SHUT OFF [QVX:SEFI4]

Hexadecimal	02h	41h	44h	5Ah	5Ah	3Bh	51h	56h	58h	3Ah
Character		A	D	Z	Z	;	Q	V	X	:
Hexadecimal	53h	45h	46h	49h	34h	03h				
Character	S	E	F	I	4					

■ Response (Callback)

In the period when the command can be accepted

Hexadecimal	02h	53h	45h	46h	49h	34h	3Dh	2Bh	*1	*3
Character		S	E	F	I	4	=	+	*2	*4
Hexadecimal	*5	*7	*9	03h						
Character	*6	*8	*10							

Acceptability

SECURITY	STANDBY	ECO STANDBY	NO SIGNAL	SHUTTER	FREEZE	TEST PATTERN	REMOTE2	P IN P	LENS HOME
✓	✓		✓	✓	✓	✓	✓	✓	✓

■ Parameters (*1,*2,*3,*4,*5,*6,*7,*8,*9,*10)

	OPEN					CLOSE				
Hexadecimal	30h	30h	30h	30h	30h	30h	30h	30h	30h	31h
Character	0	0	0	0	0	0	0	0	0	1
	KEEP CURRENT STATE									
Hexadecimal	30h	30h	30h	30h	32h					
Character	0	0	0	0	2					

3.431. QUERY WAVEFORM MONITOR [QWM]

Hexadecimal	02h	41h	44h	5Ah	5Ah	3Bh	51h	47h	4Dh	03h
Character		A	D	Z	Z	;	Q	W	M	

■ Response (Callback)

In the period when the command can be accepted

Hexadecimal	02h	*1	03h
Character		*2	

Acceptability

SECURITY	STANDBY	ECO STANDBY	NO SIGNAL	SHUTTER	FREEZE	TEST PATTERN	REMOTE2	P IN P	LENS HOME
✓			✓	✓	✓	✓	✓		✓

■ Parameters (*1,*2)

	OFF	Luminance-line	Red-line	Green-line	Blue-line
Hexadecimal	30h	35h	36h	37h	38h
Character	0	5	6	7	8

3.432. QUERY WAVEFORM MONITOR - ADJUST LEVEL [QVX:WMLI0]

Hexadecimal	02h	41h	44h	5Ah	5Ah	3Bh	51h	56h	58h	3Ah
Character		A	D	Z	Z	;	Q	V	X	:

Hexadecimal	57h	4Dh	4Ch	49h	30h	03h
Character	W	M	L	l	0	

■ Response (Callback)

In the period when the command can be accepted

Hexadecimal	02h	57h	4Dh	4Ch	49h	30h	3Dh	2Bh
Character		W	M	L	l	0	=	+
Hexadecimal	*1	*3	*5	*7	*9	03h		
Character	*2	*4	*6	*8	*10			

Acceptability

SECURITY	STANDBY	ECO STANDBY	NO SIGNAL	SHUTTER	FREEZE	TEST PATTERN	REMOTE2	P IN P	LENS HOME
✓			✓	✓	✓	✓	✓		✓

■ Parameters (*1,*2,*3,*4,*5,*6,*7,*8,*9,*10)

	0					1				
Hexadecimal	30h	30h	30h	30h	30h	30h	30h	30h	30h	31h
Character	0	0	0	0	0	0	0	0	0	1
	1198					1199				
Hexadecimal	30h	31h	31h	39h	38h	30h	31h	31h	39h	39h
Character	0	1	1	9	8	0	1	1	9	9

3.433. QUERY CUT OFF - RED [QVX:CUT1]

Hexadecimal	02h	41h	44h	5Ah	5Ah	3Bh	51h	56h	58h	3Ah
Character		A	D	Z	Z	;	Q	V	X	:

Hexadecimal	43h	55h	54h	49h	31h	03h
Character	C	U	T	l	1	

■ Response (Callback)

In the period when the command can be accepted

Hexadecimal	02h	43h	55h	54h	49h	31h	3Dh	2Bh	*1	*3
Character		C	U	T	l	1	=	+	*2	*4
Hexadecimal	*5	*7	*9	03h						
Character	*6	*8	*10							

Acceptability

SECURITY	STANDBY	ECO STANDBY	NO SIGNAL	SHUTTER	FREEZE	TEST PATTERN	REMOTE2	P IN P	LENS HOME
✓			✓	✓	✓	✓	✓	✓	✓

■ Parameters (*1,*2,*3,*4,*5,*6,*7,*8,*9,*10)

	OFF					ON				
Hexadecimal	30h	30h	30h	30h	30h	30h	30h	30h	30h	31h
Character	0	0	0	0	0	0	0	0	0	1

3.434. QUERY CUT OFF - GREEN [QVX:CUT2]

Hexadecimal	02h	41h	44h	5Ah	5Ah	3Bh	51h	56h	58h	3Ah
Character		A	D	Z	Z	;	Q	V	X	:

Hexadecimal	43h	55h	54h	49h	32h	03h
Character	C	U	T	l	2	

■ Response (Callback)

In the period when the command can be accepted

Hexadecimal	02h	43h	55h	54h	49h	32h	3Dh	2Bh	*1	*3
Character		C	U	T	l	2	=	+	*2	*4
Hexadecimal	*5	*7	*9	03h						
Character	*6	*8	*10							

Acceptability

SECURITY	STANDBY	ECO STANDBY	NO SIGNAL	SHUTTER	FREEZE	TEST PATTERN	REMOTE2	P IN P	LENS HOME
✓			✓	✓	✓	✓	✓	✓	✓

■ Parameters (*1,*2,*3,*4,*5,*6,*7,*8,*9,*10)

	OFF					ON				
Hexadecimal	30h	30h	30h	30h	30h	30h	30h	30h	30h	31h
Character	0	0	0	0	0	0	0	0	0	1

3.435. QUERY CUT OFF - BLUE [QVX:CUTI3]

Hexadecimal	02h	41h	44h	5Ah	5Ah	3Bh	51h	56h	58h	3Ah
Character		A	D	Z	Z	;	Q	V	X	:
Hexadecimal	43h	55h	54h	49h	33h	03h				
Character	C	U	T	I	3					

■ Response (Callback)

In the period when the command can be accepted

Hexadecimal	02h	43h	55h	54h	49h	33h	3Dh	2Bh	*1	*3
Character		C	U	T	I	3	=	+	*2	*4
Hexadecimal	*5	*7	*9	03h						
Character	*6	*8	*10							

Acceptability

SECURITY	STANDBY	ECO STANDBY	NO SIGNAL	SHUTTER	FREEZE	TEST PATTERN	REMOTE2	P IN P	LENS HOME
✓			✓	✓	✓	✓	✓	✓	✓

■ Parameters (*1,*2,*3,*4,*5,*6,*7,*8,*9,*10)

	OFF					ON				
Hexadecimal	30h	30h	30h	30h	30h	30h	30h	30h	30h	31h
Character	0	0	0	0	0	0	0	0	0	1

3.436. QUERY PROJECTION METHOD [QSP]

Hexadecimal	02h	41h	44h	5Ah	5Ah	3Bh	51h	53h	50h	03h
Character		A	D	Z	Z	;	Q	S	P	

■ Response (Callback)

	FRONT/FLOOR			REAR/FLOOR			FRONT/CEILING			REAR/CEILING		
Hexadecimal	02h	30h	03h	02h	31h	03h	02h	32h	03h	02h	33h	03h
Character		0			1			2			3	

Acceptability

SECURITY	STANDBY	ECO STANDBY	NO SIGNAL	SHUTTER	FREEZE	TEST PATTERN	REMOTE2	P IN P	LENS HOME
✓	✓		✓	✓	✓	✓	✓	✓	✓

3.437. QUERY COOLING CONDITION [QDR]

Hexadecimal	02h	41h	44h	5Ah	5Ah	3Bh	51h	44h	52h	03h
Character		A	D	Z	Z	;	Q	D	R	

■ Response (Callback)

	FLOOR			CEILING			VERTICAL UP		
Hexadecimal	02h	30h	03h	02h	31h	03h	02h	32h	03h
Character		0			1			2	
	VERTICAL DOWN			PORTRAIT			AUTO		
Hexadecimal	02h	33h	03h	02h	34h	03h	02h	39h	03h
Character		3			4			9	

Acceptability

SECURITY	STANDBY	ECO STANDBY	NO SIGNAL	SHUTTER	FREEZE	TEST PATTERN	REMOTE2	P IN P	LENS HOME
✓	✓		✓	✓	✓	✓	✓	✓	✓

3.438. QUERY AUTO COOLING CONDITION - STATUS [QVX:ADRI1]

Hexadecimal	02h	41h	44h	5Ah	5Ah	3Bh	51h	56h	88h	3Ah
Character		A	D	Z	Z	;	Q	V	X	:
Hexadecimal	41h	44h	52h	49h	31h	03h				
Character	A	D	R	I	1					

■ Response (Callback)

In the period when the command can be accepted

Hexadecimal	02h	41h	44h	52h	49h	31h	3Dh	2Bh
Character		A	D	R	I	1	=	+
Hexadecimal	*1	*3	*5	*7	*9	03h		
Character	*2	*4	*6	*8	*10			

Acceptability

SECURITY	STANDBY	ECO STANDBY	NO SIGNAL	SHUTTER	FREEZE	TEST PATTERN	REMOTE2	P IN P	LENS HOME
✓	✓	✓	✓	✓	✓	✓	✓	✓	✓

■ Parameters (*1,*2,*3,*4,*5,*6,*7,*8,*9,*10)

	FLOOR					CEILING					VERTICAL UP				
Hexadecimal	30h	30h	30h	30h	30h	30h	30h	30h	30h	31h	30h	30h	30h	30h	32h
Character	0	0	0	0	0	0	0	0	0	1	0	0	0	0	2
	VERTICAL DOWN					PORTRAIT									
Hexadecimal	30h	30h	30h	30h	34h	30h	30h	30h	30h	35h					
Character	0	0	0	0	4	0	0	0	0	5					

3.439. QUERY RUNTIME - PROJECTOR [QST]

Hexadecimal	02h	41h	44h	5Ah	5Ah	3Bh	51h	53h	54h	03h
Character		A	D	Z	Z	;	Q	S	T	

■ Response (Callback)

In the period when the command can be accepted

Hexadecimal	02h	*1	*3	*5	*7	*9	03h
Character		*2	*4	*6	*8	*10	

Acceptability

SECURITY	STANDBY	ECO STANDBY	NO SIGNAL	SHUTTER	FREEZE	TEST PATTERN	REMOTE2	P IN P	LENS HOME
✓	✓	✓	✓	✓	✓	✓	✓	✓	✓

■ Parameters (*1,*2,*3,*4,*5,*6,*7,*8,*9,*10)

	0h					1h				
Hexadecimal	30h	30h	30h	30h	30h	30h	30h	30h	30h	31h
Character	0	0	0	0	0	0	0	0	0	1
	99998h					99999h				
Hexadecimal	39h	39h	39h	39h	38h	39h	39h	39h	39h	39h
Character	9	9	9	9	8	9	9	9	9	9

3.440. QUERY LAMP SELECT [QSL]

Hexadecimal	02h	41h	44h	5Ah	5Ah	3Bh	51h	53h	4Ch	03h
Character		A	D	Z	Z	;	Q	S	L	

■ Response (Callback)

	DUAL			SINGL			LAMP 1			LAMP 2		
Hexadecimal	02h	30h	03h	02h	31h	03h	02h	32h	03h	02h	33h	03h
Character		0			1			2			3	

Acceptability

SECURITY	STANDBY	ECO STANDBY	NO SIGNAL	SHUTTER	FREEZE	TEST PATTERN	REMOTE2	P IN P	LENS HOME
✓	✓	✓	✓	✓	✓	✓	✓	✓	✓

3.441. QUERY LAMP RELAY [QVX:LRYI0]

Hexadecimal	02h	41h	44h	5Ah	5Ah	3Bh	51h	56h	88h	3Ah
Character		A	D	Z	Z	;	Q	V	X	:
Hexadecimal	4Ch	52h	59h	49h	30h	03h				
Character	L	R	Y	I	0					

■ Response (Callback)

In the period when the command can be accepted

Hexadecimal	02h	4Ch	52h	59h	49h	30h	3Dh	2Bh
Character		L	R	Y	I	0	=	+
Hexadecimal	*1	*3	*5	*7	*9	03h		
Character	*2	*4	*6	*8	*10			

Acceptability

SECURITY	STANDBY	ECO STANDBY	NO SIGNAL	SHUTTER	FREEZE	TEST PATTERN	REMOTE2	P IN P	LENS HOME
✓	✓	✓	✓	✓	✓	✓	✓	✓	✓

■ Parameters (*1,*2,*3,*4,*5,*6,*7,*8,*9,*10)

	OFF					00:01					00:02				
Hexadecimal	30h	30h	30h	30h	30h	30h	30h	30h	30h	31h	30h	30h	30h	30h	32h
Character	0	0	0	0	0	0	0	0	0	1	0	0	0	0	2
	23:58					23:59					00:00				
Hexadecimal	30h	32h	33h	35h	38h	30h	32h	33h	35h	39h	30h	32h	34h	30h	30h
Character	0	2	3	5	8	0	2	3	5	9	0	2	4	0	0

3.442. QUERY LAMP RELAY - WEEK [QVX:LRYI2]

Hexadecimal	02h	41h	44h	5Ah	5Ah	3Bh	51h	56h	88h	3Ah
Character		A	D	Z	Z	;	Q	V	X	:
Hexadecimal	4Ch	52h	59h	49h	32h	03h				
Character	L	R	Y	I	2					

■ Response (Callback)

In the period when the command can be accepted

Hexadecimal	02h	4Ch	52h	59h	49h	32h	3Dh	2Bh
Character		L	R	Y	I	2	=	+
Hexadecimal	*1	*3	*5	*7	*9	03h		
Character	*2	*4	*6	*8	*10			

Acceptability

SECURITY	STANDBY	ECO STANDBY	NO SIGNAL	SHUTTER	FREEZE	TEST PATTERN	REMOTE2	P IN P	LENS HOME
✓		✓	✓	✓	✓	✓	✓	✓	✓

■ Parameters (*1,*2,*3,*4,*5,*6,*7,*8,*9,*10)

	OFF					24H					SUN				
Hexadecimal	30h	30h	30h	30h	30h	30h	30h	30h	30h	31h	30h	30h	30h	30h	32h
Character	0	0	0	0	0	0	0	0	0	1	0	0	0	0	2
	MON					TUE					WED				
Hexadecimal	30h	30h	30h	30h	33h	30h	30h	30h	30h	34h	30h	30h	30h	30h	35h
Character	0	0	0	0	3	0	0	0	0	4	0	0	0	0	5
	THU					FRI					SAT				
Hexadecimal	30h	30h	30h	30h	36h	30h	30h	30h	30h	37h	30h	30h	30h	30h	38h
Character	0	0	0	0	6	0	0	0	0	7	0	0	0	0	8

3.443. QUERY LAMP POWER [QVX:LPW11]

Hexadecimal	02h	41h	44h	5Ah	5Ah	3Bh	51h	56h	88h	3Ah
Character		A	D	Z	Z	;	Q	V	X	:
Hexadecimal	4Ch	50h	57h	49h	31h	03h				
Character	L	P	W	I	1					

■ Response (Callback)

In the period when the command can be accepted

Hexadecimal	02h	4Ch	50h	57h	49h	31h	3Dh	2Bh
Character		L	P	W	I	1	=	+
Hexadecimal	*1	*3	*5	*7	*9	03h		
Character	*2	*4	*6	*8	*10			

Acceptability

SECURITY	STANDBY	ECO STANDBY	NO SIGNAL	SHUTTER	FREEZE	TEST PATTERN	REMOTE2	P IN P	LENS HOME
✓	✓	✓	✓	✓	✓	✓	✓	✓	✓

■ Parameters (*1,*2,*3,*4,*5,*6,*7,*8,*9,*10)

	ECO					NORMAL				
Hexadecimal	30h	30h	30h	30h	30h	30h	30h	30h	30h	31h
Character	0	0	0	0	0	0	0	0	0	1

3.444. QUERY BRIGHTNESS CONTROL - GAIN [QVX:TGA10]

Hexadecimal	02h	41h	44h	5Ah	5Ah	3Bh	51h	56h	58h	3Ah
Character		A	D	Z	Z	;	Q	V	X	:
Hexadecimal	54h	47h	41h	49h	30h	03h				
Character	T	G	A	I	0					

■ Response (Callback)

In the period when the command can be accepted

Hexadecimal	02h	54h	47h	41h	49h	30h	3Dh	2Bh	*1	*3
Character		T	G	A	I	0	=	+	*2	*4
Hexadecimal	*5	*7	*9	03h						
Character	*6	*8	*10							

Acceptability

SECURITY	STANDBY	ECO STANDBY	NO SIGNAL	SHUTTER	FREEZE	TEST PATTERN	REMOTE2	P IN P	LENS HOME
✓	✓		✓	✓	✓	✓	✓	✓	✓

■ Parameters (*1,*2,*3,*4,*5,*6,*7,*8,*9,*10)

	20%					21%				
Hexadecimal	30h	30h	30h	32h	30h	30h	30h	30h	32h	31h
Character	0	0	0	2	0	0	0	0	2	1
	99%					100%				
Hexadecimal	30h	30h	30h	39h	39h	30h	30h	30h	30h	30h
Character	0	0	0	9	9	0	0	1	0	0

3.445. QUERY BRIGHTNESS CONTROL - MODE [QVX:BCMI0]

Hexadecimal	02h	41h	44h	5Ah	5Ah	3Bh	51h	56h	58h	3Ah
Character		A	D	Z	Z	;	Q	V	X	:
Hexadecimal	42h	43h	4Dh	49h	30h	03h				
Character	B	C	M	I	0					

■ Response (Callback)

In the period when the command can be accepted

Hexadecimal	02h	42h	43h	4Dh	49h	30h	3Dh	2Bh	*1	*3
Character		B	C	M	I	0	=	+	*2	*4
Hexadecimal	*5	*7	*9	03h						
Character	*6	*8	*10							

Acceptability

SECURITY	STANDBY	ECO STANDBY	NO SIGNAL	SHUTTER	FREEZE	TEST PATTERN	REMOTE2	P IN P	LENS HOME
✓	✓		✓	✓	✓	✓	✓	✓	✓

■ Parameters (*1,*2,*3,*4,*5,*6,*7,*8,*9,*10)

	OFF					AUTO				
Hexadecimal	30h	30h	30h	30h	30h	30h	30h	30h	30h	31h
Character	0	0	0	0	0	0	0	0	0	1
	PC									
Hexadecimal	30h	30h	30h	30h	32h					
Character	0	0	0	0	2					

3.446. QUERY BRIGHTNESS CONTROL - LINK [QVX:BCLIO]

Hexadecimal	02h	41h	44h	5Ah	5Ah	3Bh	51h	56h	58h	3Ah
Character		A	D	Z	Z	;	Q	V	X	:
Hexadecimal	42h	43h	4Ch	49h	30h	03h				
Character	B	C	L	I	0					

■ Response (Callback)

In the period when the command can be accepted

Hexadecimal	02h	42h	43h	4Ch	49h	30h	3Dh	2Bh	*1	*3
Character		B	C	L	I	0	=	+	*2	*4
Hexadecimal	*5	*7	*9	03h						
Character	*6	*8	*10							

Acceptability

SECURITY	STANDBY	ECO STANDBY	NO SIGNAL	SHUTTER	FREEZE	TEST PATTERN	REMOTE2	P IN P	LENS HOME
✓	✓		✓	✓	✓	✓	✓	✓	✓

■ Parameters (*1,*2,*3,*4,*5,*6,*7,*8,*9,*10)

	OFF					GROUP A				
Hexadecimal	30h	30h	30h	30h	30h	30h	30h	30h	30h	31h
Character	0	0	0	0	0	0	0	0	0	1
	GROUP B					GROUP C				
Hexadecimal	30h	30h	30h	30h	32h	30h	30h	30h	30h	33h
Character	0	0	0	0	2	0	0	0	0	3
	GROUP D									
Hexadecimal	30h	30h	30h	30h	34h					
Character	0	0	0	0	4					

3.447. QUERY BRIGHTNESS CONTROL - CALIBRATION TIME [QVX:BTMI1]

Hexadecimal	02h	41h	44h	5Ah	5Ah	3Bh	51h	56h	58h	3Ah
Character		A	D	Z	Z	;	Q	V	X	:
Hexadecimal	42h	54h	4Dh	49h	31h	03h				
Character	B	T	M	I	1					

■ Response (Callback)

In the period when the command can be accepted

Hexadecimal	02h	42h	54h	4Dh	49h	31h	3Dh	2Bh	*1	*3
Character		B	T	M	I	1	=	+	*2	*4
Hexadecimal	*5	*7	*9	03h						
Character	*6	*8	*10							

Acceptability

SECURITY	STANDBY	ECO STANDBY	NO SIGNAL	SHUTTER	FREEZE	TEST PATTERN	REMOTE2	P IN P	LENS HOME
✓	✓		✓	✓	✓	✓	✓	✓	✓

■ Parameters (*1,*2,*3,*4,*5,*6,*7,*8,*9,*10)

	OFF					00:01				
Hexadecimal	30h	30h	30h	30h	30h	30h	30h	30h	30h	31h
Character	0	0	0	0	0	0	0	0	0	1
	23:59					00:00				
Hexadecimal	30h	32h	33h	35h	39h	30h	32h	34h	30h	30h
Character	0	2	3	5	9	0	2	4	0	0

3.448. QUERY BRIGHTNESS CONTROL - CALIBRATION MESSAGE [QVX:BMGI1]

Hexadecimal	02h	41h	44h	5Ah	5Ah	3Bh	51h	56h	58h	3Ah
Character		A	D	Z	Z	;	Q	V	X	:
Hexadecimal	42h	4Dh	47h	49h	31h	03h				
Character	B	M	G	I	1					

■ Response (Callback)

In the period when the command can be accepted

Hexadecimal	02h	42h	4Dh	47h	49h	31h	3Dh	2Bh	*1	*3
Character		B	M	G	I	1	=	+	*2	*4
Hexadecimal	*5	*7	*9	03h						
Character	*6	*8	*10							

Acceptability

SECURITY	STANDBY	ECO STANDBY	NO SIGNAL	SHUTTER	FREEZE	TEST PATTERN	REMOTE2	P IN P	LENS HOME
✓	✓		✓	✓	✓	✓	✓	✓	✓

Parameters (*1,*2,*3,*4,*5,*6,*7,*8,*9,*10)

	OFF					ON				
Hexadecimal	30h	30h	30h	30h	30h	30h	30h	30h	30h	31h
Character	0	0	0	0	0	0	0	0	0	1

3.449. QUERY STANDBY MODE [QVX:STMI0]

Hexadecimal	02h	41h	44h	5Ah	5Ah	3Bh	51h	56h	58h	3Ah
Character		A	D	Z	Z	;	Q	V	X	:
Hexadecimal	53h	54h	4Dh	49h	30h	03h				
Character	S	T	M	I	0					

■ Response (Callback)

In the period when the command can be accepted

Hexadecimal	02h	53h	54h	4Dh	49h	30h	3Dh	2Bh	*1	*3
Character		S	T	M	I	0	=	+	*2	*4
Hexadecimal	*5	*7	*9	03h						
Character	*6	*8	*10							

Acceptability

SECURITY	STANDBY	ECO STANDBY	NO SIGNAL	SHUTTER	FREEZE	TEST PATTERN	REMOTE2	P IN P	LENS HOME
✓	✓	✓	✓	✓	✓	✓	✓	✓	✓

■ Parameters (*1,*2,*3,*4,*5,*6,*7,*8,*9,*10)

	NORMAL					ECO				
Hexadecimal	30h	30h	30h	30h	30h	30h	30h	30h	30h	33h
Character	0	0	0	0	0	0	0	0	0	3

3.450. QUERY SCHEDULE [QVX:SCHI0]

Hexadecimal	02h	41h	44h	5Ah	5Ah	3Bh	51h	56h	58h	3Ah
Character		A	D	Z	Z	;	Q	V	X	:
Hexadecimal	53h	43h	48h	49h	30h	03h				
Character	S	C	H	I	0					

■ Response (Callback)

In the period when the command can be accepted

Hexadecimal	02h	53h	43h	48h	49h	30h	3Dh	2Bh	*1	*3
Character		S	C	H	I	0	=	+	*2	*4
Hexadecimal	*5	*7	*9	03h						
Character	*6	*8	*10							

Acceptability

SECURITY	STANDBY	ECO STANDBY	NO SIGNAL	SHUTTER	FREEZE	TEST PATTERN	REMOTE2	P IN P	LENS HOME
✓	✓		✓	✓	✓	✓	✓	✓	✓

■ Parameters (*1,*2,*3,*4,*5,*6,*7,*8,*9,*10)

	OFF					ON				
Hexadecimal	30h	30h	30h	30h	30h	30h	30h	30h	30h	31h
Character	0	0	0	0	0	0	0	0	0	1

3.451. QUERY SCHEDULE - PROGRAM ASSIGN [QVX:SPGI]

Hexadecimal	02h	41h	44h	5Ah	5Ah	3Bh	51h	56h	58h	3Ah
Character		A	D	Z	Z	;	Q	V	X	:
Hexadecimal	53h	50h	47h	49h	*1	03h				
Character	S	P	G	I	*2					

■ Response (Callback)

In the period when the command can be accepted

Hexadecimal	02h	53h	50h	47h	49h	*1	3Dh	2Bh	*3	*5
Character		S	P	G	I	*2	=	+	*4	*6
Hexadecimal	*7	*9	*11	03h						
Character	*8	*10	*12							

Acceptability

SECURITY	STANDBY	ECO STANDBY	NO SIGNAL	SHUTTER	FREEZE	TEST PATTERN	REMOTE2	P IN P	LENS HOME
✓	✓		✓	✓	✓	✓	✓	✓	✓

■ Parameters (*1,*2)

	Sun	Mon	Tue	Wed	Thu	Fri	Sat
Hexadecimal	30h	31h	32h	33h	34h	35h	36h
Character	0	1	2	3	4	5	6

■ Parameters (*3,*4,*5,*6,*7,*8,*9,*10,*11,*12)

	OFF					PROGRAM 1					PROGRAM 2				
Hexadecimal	30h	30h	30h	30h	30h	30h	30h	30h	30h	31h	30h	30h	30h	30h	32h
Character	0	0	0	0	0	0	0	0	0	1	0	0	0	0	2
	PROGRAM 3					PROGRAM 4					PROGRAM 5				
Hexadecimal	30h	30h	30h	30h	33h	30h	30h	30h	30h	34h	30h	30h	30h	30h	35h
Character	0	0	0	0	3	0	0	0	0	4	0	0	0	0	5
	PROGRAM 6					PROGRAM 7									
Hexadecimal	30h	30h	30h	30h	36h	30h	30h	30h	30h	37h					
Character	0	0	0	0	6	0	0	0	0	7					

3.452. QUERY SCHEDULE - COMMAND SETTING [QVX:SCCS]

Hexadecimal	02h	41h	44h	5Ah	5Ah	3Bh	51h	56h	58h	3Ah
Character		A	D	Z	Z	;	Q	V	X	:
Hexadecimal	53h	43h	43h	53h	*1	3Dh	*3	*5	03h	
Character	S	C	C	S	*2	=	*4	*6		

■ Response (Callback)

In the period when the command can be accepted

Hexadecimal	02h	53h	43h	43h	53h	*1	3Dh	2Bh	*3	*5
Character		S	C	C	S	*2	=	+	*4	*6
Hexadecimal	*7	*9	*11	*13	*15	*17	03h			
Character	*8	*10	*12	*14	*16	*18				

Acceptability

SECURITY	STANDBY	ECO STANDBY	NO SIGNAL	SHUTTER	FREEZE	TEST PATTERN	REMOTE2	P IN P	LENS HOME
✓	✓		✓	✓	✓	✓	✓	✓	✓

■ Parameters (*1,*2)

	PROGRAM 1	PROGRAM 2	PROGRAM 3	PROGRAM 4	PROGRAM 5	PROGRAM 6	PROGRAM 7
Hexadecimal	31h	32h	33h	34h	35h	36h	37h
Character	1	2	3	4	5	6	7

■ Parameters (*3,*4,*5,*6)

	COMMAND 1		COMMAND 2		COMMAND 3		COMMAND 14		COMMAND 15		COMMAND 16	
Hexadecimal	30h	31h	30h	32h	30h	33h	31h	34h	31h	35h	31h	36h
Character	0	1	0	2	0	3	1	4	1	5	1	6

■ Parameters (*7,*8,*9,*10)

	Command Deleting		STANDBY		PPOWER ON		SHUTTER Open		SHUTTER Colosed	
Hexadecimal	30h	30h	31h	30h	31h	31h	32h	30h	32h	31h
Character	0	0	1	0	1	1	2	0	2	1
	RGB1 INPUT		RGB2 INPUT		DVI INPUT		SDI INPUT		HDMI INPUT	
Hexadecimal	33h	31h	33h	32h	35h	31h	35h	32h	35h	33h
Character	3	1	3	2	5	1	5	2	5	3
	LAMP POWER NORMAL		LAMP POWER ECO		SINGLE LAMP		DUAL LAMP		DIGITAL LINK INPUT	
Hexadecimal	37h	30h	37h	31h	38h	31h	38h	33h	42h	30h
Character	7	0	7	1	8	1	8	2	B	0
	INPUT 1		INPUT 2		INPUT 3		INPUT 4		INPUT 5	
Hexadecimal	42h	31h	42h	32h	42h	33h	42h	34h	42h	35h
Character	B	1	B	2	B	3	B	4	B	5
	INPUT 6		INPUT 7		INPUT 8		INPUT 9		INPUT 10	
Hexadecimal	42h	36h	42h	37h	42h	38h	42h	39h	42h	3Ah
Character	B	6	B	7	B	8	B	9	B	A
	P IN P OFF		P IN P USER1		P IN P USER2		P IN P USER3			
Hexadecimal	39h	30h	39h	31h	39h	32h	39h	33h		
Character	9	0	9	1	9	2	9	3		

3.453. QUERY INITIAL STARTUP [QPY]

Hexadecimal	02h	41h	44h	5Ah	5Ah	3Bh	51h	50h	59h	03h
Character		A	D	Z	Z	;	Q	P	Y	

■ Response (Callback)

	STANDBY			ON			LAST MEMORY		
Hexadecimal	02h	30h	03h	02h	31h	03h	02h	32h	03h
Character		0			1			2	

Acceptability

SECURITY	STANDBY	ECO STANDBY	NO SIGNAL	SHUTTER	FREEZE	TEST PATTERN	REMOTE2	P IN P	LENS HOME
✓			✓	✓	✓	✓	✓	✓	✓

3.454. QUERY STARTUP INPUT SELECT [QVX:SISS1]

Hexadecimal	02h	41h	44h	5Ah	5Ah	3Bh	51h	56h	58h	3Ah
Character		A	D	Z	Z	;	Q	V	X	:
Hexadecimal	53h	49h	53h	53h	31h	03h				
Character	S	I	S	S	1					

■ Response (Callback)

In the period when the command can be accepted

Hexadecimal	02h	53h	49h	53h	53h	31h	3Dh	2Bh	*1	*3
Character		S	I	S	S	1	=	+	*2	*4
Hexadecimal	*5	*7	*9	03h						
Character	*6	*8	*10							

Acceptability

SECURITY	STANDBY	ECO STANDBY	NO SIGNAL	SHUTTER	FREEZE	TEST PATTERN	REMOTE2	P IN P	LENS HOME
✓	✓		✓	✓	✓	✓	✓	✓	✓

■ Parameters (*1,*2,*3,*4,*5,*6,*7,*8,*9,*10)

	RGB1			RGB2			DVI-D					
Hexadecimal	52h	47h	31h	52h	47h	32h	44h	56h	49h			
Character	R	G	1	R	G	2	D	V	I			
	HDMI1			DIGITAL LINK			SDI			LAST USED		
Hexadecimal	48h	44h	31h	44h	4Ch	31h	53h	44h	31h	4Ch	53h	55h
Character	H	D	1	D	L	1	S	D	1	L	S	U

3.455. QUERY STARTUP INPUT SELECT (DIGITAL LINK) [QVX:SISS2]

Hexadecimal	02h	41h	44h	5Ah	5Ah	3Bh	51h	56h	58h	3Ah
Character		A	D	Z	Z	;	Q	V	X	:
Hexadecimal	53h	49h	53h	53h	32h	03h				
Character	S	I	S	S	2					

■ Response (Callback)

In the period when the command can be accepted

Hexadecimal	02h	53h	49h	53h	53h	32h	3Dh	2Bh	*1	*3
Character		S	I	S	S	2	=	+	*2	*4
Hexadecimal	*5	*7	*9	03h						
Character	*6	*8	*10							

Acceptability

SECURITY	STANDBY	ECO STANDBY	NO SIGNAL	SHUTTER	FREEZE	TEST PATTERN	REMOTE2	P IN P	LENS HOME
✓	✓		✓	✓	✓	✓	✓	✓	✓

■ Parameters (*1,*2,*3,*4,*5,*6,*7,*8,*9,*10)

	LAST USED					INPUT 1				
Hexadecimal	30h	30h	30h	30h	30h	30h	30h	30h	30h	31h
Character	0	0	0	0	0	0	0	0	0	1
	INPUT 2					INPUT 3				
Hexadecimal	30h	30h	30h	30h	32h	30h	30h	30h	30h	33h
Character	0	0	0	0	2	0	0	0	0	3
	INPUT 4					INPUT 5				
Hexadecimal	30h	30h	30h	30h	34h	30h	30h	30h	30h	35h
Character	0	0	0	0	4	0	0	0	0	5
	INPUT 6					INPUT 7				
Hexadecimal	30h	30h	30h	30h	36h	30h	30h	30h	30h	37h
Character	0	0	0	0	6	0	0	0	0	7
	INPUT 8					INPUT 9				
Hexadecimal	30h	30h	30h	30h	38h	30h	30h	30h	30h	39h
Character	0	0	0	0	8	0	0	0	0	9
	INPUT 10									
Hexadecimal	30h	30h	30h	31h	30h					
Character	0	0	0	1	0					

3.456. QUERY NO SIGNAL SHUT-OFF [QAF]

Hexadecimal	02h	41h	44h	5Ah	5Ah	3Bh	51h	41h	46h	03h
Character		A	D	Z	Z	;	Q	A	F	

■ Response (Callback)

In the period when the command can be accepted

Hexadecimal	02h	*1	*3	03h
Character		*2	*4	

Acceptability

SECURITY	STANDBY	ECO STANDBY	NO SIGNAL	SHUTTER	FREEZE	TEST PATTERN	REMOTE2	P IN P	LENS HOME
✓			✓	✓	✓	✓	✓	✓	✓

■ Parameters (*1,*2,*3,*4)

	DISABLE		10 MIN.		20 MIN.		30 MIN.		40 MIN.	
Hexadecimal	30h	30h	31h	30h	32h	30h	33h	30h	34h	30h
Character	0	0	1	0	2	0	3	0	4	0
	50 MIN.		60 MIN.		70 MIN.		80 MIN.		90 MIN.	
Hexadecimal	35h	30h	36h	30h	37h	30h	38h	30h	39h	30h
Character	5	0	6	0	7	0	8	0	9	0

3.457. QUERY FUNCTION BUTTON SETTING [QFC]

Hexadecimal	02h	41h	44h	5Ah	5Ah	3Bh	51h	46h	43h	03h
Character		A	D	Z	Z	;	Q	F	C	

■ Response (Callback)

	DISABLE			SYSTEM SELECTOR			SYSTEM DAYLIGHT VIEW			SUB MEMORY		
Hexadecimal	02h	30h	03h	02h	31h	03h	02h	32h	03h	02h	33h	03h
Character		0			1			2			3	
	FREEZE			P IN P			WAVEFORM MONITOR			ASPECT		
Hexadecimal	02h	34h	03h	02h	35h	03h	02h	36h	03h	02h	39h	03h
Character		4			5			6			9	

Acceptability

SECURITY	STANDBY	ECO STANDBY	NO SIGNAL	SHUTTER	FREEZE	TEST PATTERN	REMOTE2	P IN P	LENS HOME
✓	✓		✓	✓	✓	✓	✓	✓	✓

3.458. QUERY DATE AND TIME - DATE [QGD]

Hexadecimal	02h	41h	44h	5Ah	5Ah	3Bh	51h	47h	44h	03h
Character		A	D	Z	Z	;	Q	G	D	

■ Response (Callback)

Hexadecimal	02h	*y1	*y2	*y3	*y4	*m1	*m2	*d1	*d2	*w	03h
Character											

■ Parameters

*y1~*y4 : Year (4 digits)

*m1~*m2 : Month (2 digits)

*d1~*d2 : Day (2 digits)

*w : Day of the week (Mon=1, Tue=2, Wed=3, Thu=4, Fri=5, Sat=6, Sun=7)

Example: Thursday, August 17, 2010

	*y1	*y2	*y3	*y4	*m1	*m2	*d1	*d2	*w
Hexadecimal	32h	30h	31h	30h	30h	38h	31h	37h	32h
Character	2	0	1	0	0	8	1	7	2

Acceptability

SECURITY	STANDBY	ECO STANDBY	NO SIGNAL	SHUTTER	FREEZE	TEST PATTERN	REMOTE2	P IN P	LENS HOME
✓	✓		✓	✓	✓	✓	✓	✓	✓

3.459. QUERY DATE AND TIME - TIME [QGT]

Hexadecimal	02h	41h	44h	5Ah	5Ah	3Bh	51h	47h	54h	03h
Character		A	D	Z	Z	;	Q	G	T	

■ Response (Callback)

Hexadecimal	02h	*h1	*h2	*m1	*m2	*s1	*s2	03h
Character								

■ Parameters

*h1~*h2 : Hour (2 digits)

*m1~*m2 : Minute (2 digits)

*s1~*s2 : Second (2 digits)

Example: 3 seconds at 3:45 p.m

	*h1	*h2	*m1	*m2	*s1	*s2
Hexadecimal	31h	35h	34h	35h	30h	33h
Character	1	5	4	5	0	3

Acceptability

SECURITY	STANDBY	ECO STANDBY	NO SIGNAL	SHUTTER	FREEZE	TEST PATTERN	REMOTE2	P IN P	LENS HOME
✓	✓		✓	✓	✓	✓	✓	✓	✓

3.460. QUERY DATE AND TIME - NTP SYNCHRONIZATION [QVX:NTP10]

Hexadecimal	02h	41h	44h	5Ah	5Ah	3Bh	51h	56h	58h	3Ah
Character		A	D	Z	Z	;	Q	V	X	:
Hexadecimal	4Eh	54h	50h	49h	30h	03h				
Character	N	T	P	I	0					

■ Response (Callback)

In the period when the command can be accepted

Hexadecimal	02h	4Eh	54h	50h	49h	30h	3Dh	2Bh	*1	*3
Character		N	T	P	I	0	=	+	*2	*4
Hexadecimal	*5	*7	*9	03h						
Character	*6	*8	*10							

Acceptability

SECURITY	STANDBY	ECO STANDBY	NO SIGNAL	SHUTTER	FREEZE	TEST PATTERN	REMOTE2	P IN P	LENS HOME
✓	✓		✓	✓	✓	✓	✓	✓	✓

■ Parameters (*1,*2,*3,*4,*5,*6,*7,*8,*9,*10)

	OFF					ON				
Hexadecimal	30h	30h	30h	30h	30h	30h	30h	30h	30h	31h
Character	0	0	0	0	0	0	0	0	0	1

3.461. QUERY P IN P [QPP]

Hexadecimal	02h	41h	44h	5Ah	5Ah	3Bh	51h	50h	50h	03h
Character		A	D	Z	Z	;	Q	P	P	

■ Response (Callback)

In the period when the command can be accepted

Hexadecimal	02h	*1	03h
Character		*2	

Acceptability

SECURITY	STANDBY	ECO STANDBY	NO SIGNAL	SHUTTER	FREEZE	TEST PATTERN	REMOTE2	P IN P	LENS HOME
✓	✓		✓	✓		✓	✓	✓	

■ Parameters (*1,*2)

	OFF	USER1	USER2	USER3
Hexadecimal	30h	31h	32h	33h
Character	0	1	2	3

3.462. QUERY P IN P - MAIN WINDOW [QIM]

Hexadecimal	02h	41h	44h	5Ah	5Ah	3Bh	51h	49h	4Dh	03h
Character		A	D	Z	Z	;	Q	I	M	

■ Response (Callback)

In the period when the command can be accepted

Hexadecimal	02h	*1	*3	*5	03h
Character		*2	*4	*6	

Acceptability

SECURITY	STANDBY	ECO STANDBY	NO SIGNAL	SHUTTER	FREEZE	TEST PATTERN	REMOTE2	P IN P	LENS HOME
✓			✓	✓		✓	✓	✓	

■ Parameters (*1,*2,*3,*4,*5,*6)

	RGB1			RGB2			SDI		
Hexadecimal	52h	47h	31h	52h	47h	32h			
Character	R	G	1	R	G	2			
	DVI			HDMI			SDI		
Hexadecimal	44h	56h	49h	48h	44h	31h	53h	44h	31h
Character	D	V	I	H	D	1	S	D	1

3.463. QUERY P IN P - MAIN WINDOW - SIZE [QSM]

Hexadecimal	02h	41h	44h	5Ah	5Ah	3Bh	51h	53h	4Dh	03h
Character		A	D	Z	Z	;	Q	S	M	

■ Response (Callback)

In the period when the command can be accepted

Hexadecimal	02h	*1	*3	2Ch	56h	*5	*7	*9	2Ch	48h
Character		*2	*4	,	V	*6	*8	*10	,	H
Hexadecimal	*11	*13	*15	2Ch	56h	48h	*17	*19	*21	03h
Character	*12	*14	*16	,	H	V	*18	*20	*22	

Acceptability

SECURITY	STANDBY	ECO STANDBY	NO SIGNAL	SHUTTER	FREEZE	TEST PATTERN	REMOTE2	P IN P	LENS HOME
✓			✓	✓		✓	✓	✓	

■ Parameters (*1,*2,*3,*4)

INTERLOCKED

	OFF		ON	
Hexadecimal	4Fh	46h	4Fh	4Eh
Character	O	F	O	N

■ Parameters (*5,*6,*7,*8,*9,*10)

VERTICAL SIZE

	10			11			12		
Hexadecimal	30h	31h	30h	30h	31h	31h	30h	31h	32h
Character	0	1	0	0	1	1	0	1	2
	98			99			100		
Hexadecimal	30h	39h	38h	30h	39h	39h	31h	30h	30h
Character	0	9	8	0	9	9	1	0	0

■ Parameters (*11,*12,*13,*14,*15,*16)

HORIZONTAL SIZE

	10			11			12		
Hexadecimal	30h	31h	30h	30h	31h	31h	30h	31h	32h
Character	0	1	0	0	1	1	0	1	2
	98			99			100		
Hexadecimal	30h	39h	38h	30h	39h	39h	31h	30h	30h
Character	0	9	8	0	9	9	1	0	0

■ Parameters (*17,*18,*19,*20,*21,*22)

HORIZONTAL/VERTICAL SIZE

	10			11			12		
Hexadecimal	30h	31h	30h	30h	31h	31h	30h	31h	32h
Character	0	1	0	0	1	1	0	1	2
	98			99			100		
Hexadecimal	30h	39h	38h	30h	39h	39h	31h	30h	30h
Character	0	9	8	0	9	9	1	0	0

3.464. QUERY P IN P - MAIN WINDOW - POSITION [QPA]

Hexadecimal	02h	41h	44h	5Ah	5Ah	3Bh	51h	50h	41h	03h
Character		A	D	Z	Z	;	Q	P	A	

■ Response (Callback)

In the period when the command can be accepted

Hexadecimal	02h	56h	*1	*3	*5	*7	2Ch
Character		V	*2	*4	*6	*8	,
Hexadecimal	48h	*9	*11	*13	*15	03h	
Character	H	*10	*12	*14	*16		

Acceptability

SECURITY	STANDBY	ECO STANDBY	NO SIGNAL	SHUTTER	FREEZE	TEST PATTERN	REMOTE2	P IN P	LENS HOME
✓			✓	✓		✓	✓	✓	

■ Parameters (*1,*2,*3,*4,*5,*6,*7,*8,)

VERTICAL POSITION

	-364				-363				-362			
Hexadecimal	2Dh	33h	36h	34h	2Dh	33h	36h	33h	2Dh	33h	36h	32h
Character	-	3	6	4	-	3	6	3	-	3	6	2
	+362				+363				+364			
Hexadecimal	2Bh	33h	36h	32h	2Bh	33h	36h	33h	2Bh	33h	36h	34h
Character	+	3	6	2	+	3	6	3	+	3	6	4

■ Parameters (*9,*10,*11,*12,*13,*14,*15,*16)

HORIZONTAL POSITION

	-651				-650				-649			
Hexadecimal	2Dh	36h	35h	31h	2Dh	36h	35h	30h	2Dh	36h	34h	39h
Character	-	6	5	1	-	6	5	0	-	6	4	9
	+649				+650				+651			
Hexadecimal	2Bh	36h	34h	39h	2Bh	36h	35h	30h	2Bh	36h	35h	31h
Character	+	6	4	9	+	6	5	0	+	6	5	1

■ Note:

· Maximum value and minimum value are different depending by model or input signal, menu setting conditions.

3.465. QUERY P IN P - SUB WINDOW [QIS]

Hexadecimal	02h	41h	44h	5Ah	5Ah	3Bh	51h	49h	53h	03h
Character		A	D	Z	Z	;	Q	I	S	

■ Response (Callback)

In the period when the command can be accepted

Hexadecimal	02h	*1	*3	*5	03h
Character		*2	*4	*6	

Acceptability

SECURITY	STANDBY	ECO STANDBY	NO SIGNAL	SHUTTER	FREEZE	TEST PATTERN	REMOTE2	P IN P	LENS HOME
✓			✓	✓		✓	✓	✓	

■ Parameters (*1,*2,*3,*4,*5,*6)

	RGB1			RGB2						
Hexadecimal	52h	47h	31h	52h	47h	32h				
Character	R	G	1	R	G	2				
	DVI			HDMI			SDI			
Hexadecimal	44h	56h	49h	48h	44h	31h	53h	44h	31h	
Character	D	V	I	H	D	1	S	D	1	

3.466. QUERY P IN P - SUB WINDOW - SIZE [QSS]

Hexadecimal	02h	41h	44h	5Ah	5Ah	3Bh	51h	53h	53h	03h
Character		A	D	Z	Z	;	Q	S	S	

■ Response (Callback)

In the period when the command can be accepted

Hexadecimal	02h	*1	*3	2Ch	56h	*5	*7	*9	2Ch	48h
Character		*2	*4	,	V	*6	*8	*10	,	H
Hexadecimal	*11	*13	*15	2Ch	56h	48h	*17	*19	*21	03h
Character	*12	*14	*16	,	H	V	*18	*20	*22	

Acceptability

SECURITY	STANDBY	ECO STANDBY	NO SIGNAL	SHUTTER	FREEZE	TEST PATTERN	REMOTE2	P IN P	LENS HOME
✓			✓	✓		✓	✓	✓	

■ Parameters (*1,*2,*3,*4)

INTERLOCKED

	OFF		ON	
Hexadecimal	4Fh	46h	4Fh	4Eh
Character	O	F	O	N

■ Parameters (*5,*6,*7,*8,*9,*10)

VERTICAL SIZE

	10			11			12		
Hexadecimal	30h	31h	30h	30h	31h	31h	30h	31h	32h
Character	0	1	0	0	1	1	0	1	2
	98			99			100		
Hexadecimal	30h	39h	38h	30h	39h	39h	31h	30h	30h
Character	0	9	8	0	9	9	1	0	0

■ Parameters (*11,*12,*13,*14,*15,*16)

HORIZONTAL SIZE

	10			11			12		
Hexadecimal	30h	31h	30h	30h	31h	31h	30h	31h	32h
Character	0	1	0	0	1	1	0	1	2
	98			99			100		
Hexadecimal	30h	39h	38h	30h	39h	39h	31h	30h	30h
Character	0	9	8	0	9	9	1	0	0

■ Parameters (*17,*18,*19,*20,*21,*22)

HORIZONTAL/VERTICAL SIZE

	10			11			12		
Hexadecimal	30h	31h	30h	30h	31h	31h	30h	31h	32h
Character	0	1	0	0	1	1	0	1	2
	98			99			100		
Hexadecimal	30h	39h	38h	30h	39h	39h	31h	30h	30h
Character	0	9	8	0	9	9	1	0	0

3.467. QUERY P IN P - SUB WINDOW - POSITION [QPS]

Hexadecimal	02h	41h	44h	5Ah	5Ah	3Bh	51h	50h	53h	3Ah
Character		A	D	Z	Z	;	Q	P	S	:
Hexadecimal	*1	03h								
Character	*2									

■ Response (Callback)

In the period when the command can be accepted

Hexadecimal	02h	56h	*1	*3	*5	*7	2Ch
Character		V	*2	*4	*6	*8	,
Hexadecimal	48h	*9	*11	*13	*15	03h	
Character	H	*10	*12	*14	*16		

Acceptability

SECURITY	STANDBY	ECO STANDBY	NO SIGNAL	SHUTTER	FREEZE	TEST PATTERN	REMOTE2	P IN P	LENS HOME
✓			✓	✓		✓	✓	✓	

■ Parameters (*1,*2,*3,*4,*5,*6,*7,*8,)

VERTICAL POSITION

	-364				-363				-362			
Hexadecimal	2Dh	33h	36h	34h	2Dh	33h	36h	33h	2Dh	33h	36h	32h
Character	-	3	6	4	-	3	6	3	-	3	6	2
	+362				+363				+364			
Hexadecimal	2Bh	33h	36h	32h	2Bh	33h	36h	33h	2Bh	33h	36h	34h
Character	+	3	6	2	+	3	6	3	+	3	6	4

■ Parameters (*9,*10,*11,*12,*13,*14,*15,*16)

HORIZONTAL POSITION

	-651				-650				-649			
Hexadecimal	2Dh	36h	35h	31h	2Dh	36h	35h	30h	2Dh	36h	34h	39h
Character	-	6	5	1	-	6	5	0	-	6	4	9
	+649				+650				+651			
Hexadecimal	2Bh	36h	34h	39h	2Bh	36h	35h	30h	2Bh	36h	35h	31h
Character	+	6	4	9	+	6	5	0	+	6	5	1

■ Note:

· Maximum value and minimum value are different depending by model or input signal, menu setting conditions.

3.468. QUERY P IN P - SUB WINDOW - CLOCK PHASE [QVX:SCPI0]

Hexadecimal	02h	41h	44h	5Ah	5Ah	3Bh	51h	56h	58h	3Ah
Character		A	D	Z	Z	;	Q	V	X	:
Hexadecimal	53h	43h	50h	49h	30h	03h				
Character	S	C	P	I	0					

■ Response (Callback)

In the period when the command can be accepted

Hexadecimal	02h	53h	43h	50h	49h	30h	3Dh	2Bh	*1	*3
Character		S	C	P	I	0	=	+	*2	*4
Hexadecimal	*5	*7	*9	03h						
Character	*6	*8	*10							

Acceptability

SECURITY	STANDBY	ECO STANDBY	NO SIGNAL	SHUTTER	FREEZE	TEST PATTERN	REMOTE2	P IN P	LENS HOME
✓			✓	✓		✓	✓	✓	

■ Parameters (*1,*2,*3,*4,*5,*6,*7,*8,*9,*10)

	0					1				
Hexadecimal	30h	30h	30h	30h	30h	30h	30h	30h	30h	31h
Character	0	0	0	0	0	0	0	0	0	1
	30					31				
Hexadecimal	30h	30h	30h	33h	30h	30h	30h	30h	33h	31h
Character	0	0	0	3	0	0	0	0	3	1

■ Note:

· SUB CLOCK PHASE of the 3D SETTINGS can also be query.

3.469. QUERY P IN P - FRAME LOCK [QPF]

Hexadecimal	02h	41h	44h	5Ah	5Ah	3Bh	51h	50h	46h	03h
Character		A	D	Z	Z	;	Q	P	F	

■ Response (Callback)

In the period when the command can be accepted

Hexadecimal	02h	*1	03h
Character		*2	

Acceptability

SECURITY	STANDBY	ECO STANDBY	NO SIGNAL	SHUTTER	FREEZE	TEST PATTERN	REMOTE2	P IN P	LENS HOME
✓			✓	✓		✓	✓	✓	

■ Parameters (*1,*2)

	MAIN WINDOW	SUB WINDOW
Hexadecimal	30h	31h
Character	0	1

3.470. QUERY P IN P - TYPE [QPT]

Hexadecimal	02h	41h	44h	5Ah	5Ah	3Bh	51h	50h	54h	03h
Character		A	D	Z	Z	;	Q	P	T	

■ Response (Callback)

In the period when the command can be accepted

Hexadecimal	02h	*1	03h
Character		*2	

Acceptability

SECURITY	STANDBY	ECO STANDBY	NO SIGNAL	SHUTTER	FREEZE	TEST PATTERN	REMOTE2	P IN P	LENS HOME
✓			✓	✓		✓	✓	✓	

■ Parameters (*1,*2)

	MAIN WINDOW	SUB WINDOW
Hexadecimal	30h	31h
Character	0	1

3.471. QUERY - SECURITY PASSWORD SETTING [QVX:SPWI1]

Hexadecimal	02h	41h	44h	5Ah	5Ah	3Bh	51h	56h	58h	3Ah
Character		A	D	Z	Z	;	Q	V	X	:
Hexadecimal	53h	50h	57h	49h	31h	03h				
Character	S	P	W	I	1					

■ Response (Callback)

In the period when the command can be accepted

Hexadecimal	02h	53h	50h	57h	49h	31h	3Dh	2Bh	*1	*3
Character		S	P	W	I	1	=	+	*2	*4
Hexadecimal	*5	*7	*9	03h						
Character	*6	*8	*10							

Acceptability

SECURITY	STANDBY	ECO STANDBY	NO SIGNAL	SHUTTER	FREEZE	TEST PATTERN	REMOTE2	P IN P	LENS HOME
✓	✓		✓	✓	✓	✓	✓	✓	✓

■ Parameters (*1,*2,*3,*4,*5,*6,*7,*8,*9,*10)

	OFF					ON				
Hexadecimal	30h	30h	30h	30h	30h	30h	30h	30h	30h	31h
Character	0	0	0	0	0	0	0	0	0	1

3.472. QUERY NAME - PROJECTOR NAME [QVX:NCGS8]

Hexadecimal	02h	41h	44h	5Ah	5Ah	3Bh	51h	56h	58h	3Ah
Character		A	D	Z	Z	;	Q	V	X	:

Hexadecimal	4Eh	43h	47h	53h	38h	03h
Character	N	C	G	S	8	

3.472. ■ Response (Callback)

3.472. In the period when the command can be accepted

Hexadecimal	02h	4Eh	43h	47h	53h	38h	3Dh	*1	*3	*5
Character		N	C	G	S	8	=	*2	*4	*6
Hexadecimal	*7	*9	*11	*13	*15	*17	*19	*21	*23	03h
Character	*8	*10	*12	*14	*16	*18	*20	*22	*24	

3.472. Acceptability

SECURITY	STANDBY	ECO STANDBY	NO SIGNAL	SHUTTER	FREEZE	TEST PATTERN	REMOTE2	P IN P	LENS HOME
✓	✓		✓	✓	✓	✓	✓	✓	✓

3.472. ■ Parameters (*1,*2,*3,*4,*5,*6,*7,*8,*9,*10,*11,*12,*13,*14,*15,*16,*17,*18,*19,*20,*21,*22,*23,*24)

Example : PROJECTOR1

	PROJECTOR1									
Hexadecimal	50h	52h	4Fh	4Ah	45h	43h	54h	4Fh	52h	31h
Character	P	R	O	J	E	C	T	O	R	1

3.472. ■ Note:

· Responds with a undefined length name.

3.472.

3.472.

3.472.

3.472.

3.472.

3.472.

3.472.

3.472.

3.472.

3.473. QUERY NAME - SIGNAL NAME (MAIN INPUT) [QVX:NSGS1]

Hexadecimal	02h	41h	44h	5Ah	5Ah	3Bh	51h	56h	58h	3Ah
Character		A	D	Z	Z	;	Q	V	X	:
Hexadecimal	4Eh	53h	47h	53h	31h	03h				
Character	N	S	G	S	1					

■ Response (Callback)

In the period when the command can be accepted

Hexadecimal	02h	4Eh	53h	47h	53h	31h	3Dh	*1	*3	*5
Character		N	S	G	S	1	=	*2	*4	*6
Hexadecimal	*7	*9	*11	*13	*15	*17	*19	*21	*23	03h
Character	*8	*10	*12	*14	*16	*18	*20	*22	*24	

Acceptability

SECURITY	STANDBY	ECO STANDBY	NO SIGNAL	SHUTTER	FREEZE	TEST PATTERN	REMOTE2	P IN P	LENS HOME
✓			✓	✓	✓	✓	✓	✓	✓

■ Parameters(*1,*2,*3,*4,*5,*6,*7,*8,*9,*10,*11,*12,*13,*14,*15,*16,*17,*18,*19,*20,21,*22,*23,*24)

Example : 1080/60p

	1080/60p								
Hexadecimal	31h	30h	38h	30h	2Fh	36h	30h	70h	
Character	1	0	8	0	/	6	0	p	

■ Note:

· Responds with a undefined length name.

3.474. QUERY NAME - SIGNAL NAME (SUB INPUT) [QVX:NSGS2]

Hexadecimal	02h	41h	44h	5Ah	5Ah	3Bh	51h	56h	58h	3Ah
Character		A	D	Z	Z	;	Q	V	X	:
Hexadecimal	4Eh	53h	47h	53h	32h	03h				
Character	N	S	G	S	2					

■ Response (Callback)

In the period when the command can be accepted

Hexadecimal	02h	4Eh	53h	47h	53h	32h	3Dh	*1	*3	*5
Character		N	S	G	S	2	=	*2	*4	*6
Hexadecimal	*7	*9	*11	*13	*15	*17	*19	*21	*23	03h
Character	*8	*10	*12	*14	*16	*18	*20	*22	*24	

Acceptability

SECURITY	STANDBY	ECO STANDBY	NO SIGNAL	SHUTTER	FREEZE	TEST PATTERN	REMOTE2	P IN P	LENS HOME
✓			✓	✓	✓	✓	✓	✓	✓

■ Parameters(*1,*2,*3,*4,*5,*6,*7,*8,*9,*10,*11,*12,*13,*14,*15,*16,*17,*18,*19,*20,21,*22,*23,*24)

Example : NO SIGNAL

	NO SIGNAL								
Hexadecimal	4Eh	4Fh	20h	53h	49h	47h	4Eh	41h	4Ch
Character	N	O		S	I	G	N	A	L

■ Note:

· Responds with a undefined length name..

3.475. QUERY DIGITAL LINK MODE [QVX:DKMI1]

Hexadecimal	02h	41h	44h	5Ah	5Ah	3Bh	51h	56h	58h	3Ah
Character		A	D	Z	Z	;	Q	V	X	:
Hexadecimal	44h	4Bh	4Dh	49h	31h	03h				
Character	D	K	M	I	1					

■ Response (Callback)

In the period when the command can be accepted

Hexadecimal	02h	44h	4Bh	4Dh	49h	31h	3Dh	2Bh	*1	*3
Character		D	K	M	I	1	=	+	*2	*4
Hexadecimal	*5	*7	*9	03h						
Character	*6	*8	*10							

Acceptability

SECURITY	STANDBY	ECO STANDBY	NO SIGNAL	SHUTTER	FREEZE	TEST PATTERN	REMOTE2	P IN P	LENS HOME
✓	✓		✓	✓	✓	✓	✓	✓	✓

■ Parameters (*1,*2,*3,*4,*5,*6,*7,*8,*9,*10)

	AUTO					DIGITAL LINK				
Hexadecimal	30h	30h	30h	30h	31h	30h	30h	30h	30h	32h
Character	0	0	0	0	1	0	0	0	0	2
	ETHERNET					LONG REACH				
Hexadecimal	30h	30h	30h	30h	33h	30h	30h	30h	30h	34h
Character	0	0	0	0	3	0	0	0	0	4

3.476. QUERY DIGITAL LINK SETUP - DUPLEX (ETHERNET) [QVX:DKD11]

Hexadecimal	02h	41h	44h	5Ah	5Ah	3Bh	51h	56h	58h	3Ah
Character		A	D	Z	Z	;	Q	V	X	:
Hexadecimal	44h	4Bh	44h	49h	31h	03h				
Character	D	K	D	I	1					

■ Response (Callback)

In the period when the command can be accepted

Hexadecimal	02h	44h	4Bh	44h	49h	31h	3Dh	2Bh	*1	*3
Character		D	K	D	I	1	=	+	*2	*4
Hexadecimal	*5	*7	*9	03h						
Character	*6	*8	*10							

Acceptability

SECURITY	STANDBY	ECO STANDBY	NO SIGNAL	SHUTTER	FREEZE	TEST PATTERN	REMOTE2	P IN P	LENS HOME
✓	✓		✓	✓	✓	✓	✓	✓	✓

■ Parameters (*1,*2,*3,*4,*5,*6,*7,*8,*9,*10)

	AUTO					100BaseTX-Full				
Hexadecimal	30h	30h	30h	30h	30h	30h	30h	30h	30h	31h
Character	0	0	0	0	0	0	0	0	0	1
	100BaseTX-Half									
Hexadecimal	30h	30h	30h	30h	32h					
Character	0	0	0	0	2					

3.477. QUERY DIGITAL LINK SETUP - DUPLEX (DIGITAL LINK) [QVX:DKD12]

Hexadecimal	02h	41h	44h	5Ah	5Ah	3Bh	51h	56h	58h	3Ah
Character		A	D	Z	Z	;	Q	V	X	:
Hexadecimal	44h	4Bh	44h	49h	32h	03h				
Character	D	K	D	I	2					

■ Response (Callback)

In the period when the command can be accepted

Hexadecimal	02h	44h	4Bh	44h	49h	32h	3Dh	2Bh	*1	*3
Character		D	K	D	I	2	=	+	*2	*4
Hexadecimal	*5	*7	*9	03h						
Character	*6	*8	*10							

Acceptability

SECURITY	STANDBY	ECO STANDBY	NO SIGNAL	SHUTTER	FREEZE	TEST PATTERN	REMOTE2	P IN P	LENS HOME
✓	✓		✓	✓	✓	✓	✓	✓	✓

■ Parameters (*1,*2,*3,*4,*5,*6,*7,*8,*9,*10)

	AUTO					100BaseTX-Full				
Hexadecimal	30h	30h	30h	30h	30h	30h	30h	30h	30h	31h
Character	0	0	0	0	0	0	0	0	0	1
	100BaseTX-Half									
Hexadecimal	30h	30h	30h	30h	32h					
Character	0	0	0	0	2					

3.478. QUERY DIGITAL LINK STATUS - LINK STATUS [QVX:DKS11]

Hexadecimal	02h	41h	44h	5Ah	5Ah	3Bh	51h	56h	58h	3Ah
Character		A	D	Z	Z	;	Q	V	X	:
Hexadecimal	44h	4Bh	53h	49h	31h	03h				
Character	D	K	S	I	1					

■ Response (Callback)

In the period when the command can be accepted

Hexadecimal	02h	44h	4Bh	53h	49h	31h	3Dh	2Bh	*1	*3
Character		D	K	S	I	1	=	+	*2	*4
Hexadecimal	*5	*7	*9	03h						
Character	*6	*8	*10							

Acceptability

SECURITY	STANDBY	ECO STANDBY	NO SIGNAL	SHUTTER	FREEZE	TEST PATTERN	REMOTE2	P IN P	LENS HOME
✓	✓		✓	✓	✓	✓	✓	✓	✓

■ Parameters (*1,*2,*3,*4,*5,*6,*7,*8,*9,*10)

	NO LINK					DIGITAL LINK				
Hexadecimal	30h	30h	30h	30h	30h	30h	30h	30h	30h	31h
Character	0	0	0	0	0	0	0	0	0	1
	LONG REACH					ETHERNET				
Hexadecimal	30h	30h	30h	30h	32h	30h	30h	30h	30h	33h
Character	0	0	0	0	2	0	0	0	0	3

3.479. QUERY DIGITAL LINK STATUS - HDCP STATUS [QVX:DKSI2]

Hexadecimal	02h	41h	44h	5Ah	5Ah	3Bh	51h	56h	58h	3Ah
Character		A	D	Z	Z	;	Q	V	X	:
Hexadecimal	44h	4Bh	53h	49h	32h	03h				
Character	D	K	S	I	2					

■ Response (Callback)

In the period when the command can be accepted

Hexadecimal	02h	44h	4Bh	53h	49h	32h	3Dh	2Bh	*1	*3
Character		D	K	S	I	2	=	+	*2	*4
Hexadecimal	*5	*7	*9	03h						
Character	*6	*8	*10							

Acceptability

SECURITY	STANDBY	ECO STANDBY	NO SIGNAL	SHUTTER	FREEZE	TEST PATTERN	REMOTE2	P IN P	LENS HOME
✓	✓		✓	✓	✓	✓	✓	✓	✓

■ Parameters (*1,*2,*3,*4,*5,*6,*7,*8,*9,*10)

	NO SIGNAL					OFF				
Hexadecimal	30h	30h	30h	30h	30h	30h	30h	30h	30h	31h
Character	0	0	0	0	0	0	0	0	0	1
	ON									
Hexadecimal	30h	30h	30h	30h	32h					
Character	0	0	0	0	2					

3.480. QUERY DIGITAL LINK STATUS - SIGNAL QUALITY (MIN) [QVX:DKSI3]

Hexadecimal	02h	41h	44h	5Ah	5Ah	3Bh	51h	56h	58h	3Ah
Character		A	D	Z	Z	;	Q	V	X	:
Hexadecimal	44h	4Bh	53h	49h	33h	03h				
Character	D	K	S	I	3					

■ Response (Callback)

In the period when the command can be accepted

Hexadecimal	02h	44h	4Bh	53h	49h	33h	3Dh	*1	*3	*5
Character		D	K	S	I	3	=	*2	*4	*6
Hexadecimal	*7	*9	*11	03h						
Character	*8	*10	*12							

Acceptability

SECURITY	STANDBY	ECO STANDBY	NO SIGNAL	SHUTTER	FREEZE	TEST PATTERN	REMOTE2	P IN P	LENS HOME
✓			✓	✓	✓	✓	✓	✓	✓

■ Parameters (*1,*2,*3,*4,*5,*6,*7,*8,*9,*10,*11,*12)

	-255						0					
Hexadecimal	2Dh	30h	30h	32h	35h	35h	2Bh	30h	30h	30h	30h	30h
Character	—	0	0	2	5	5	+	0	0	0	0	0

3.481. QUERY DIGITAL LINK STATUS - SIGNAL QUALITY (MAX) [QVX:DKSI4]

Hexadecimal	02h	41h	44h	5Ah	5Ah	3Bh	51h	56h	58h	3Ah
Character		A	D	Z	Z	;	Q	V	X	:
Hexadecimal	44h	4Bh	53h	49h	34h	03h				
Character	D	K	S	I	4					

■ Response (Callback)

In the period when the command can be accepted

Hexadecimal	02h	44h	4Bh	53h	49h	34h	3Dh	*1	*3	*5
Character		D	K	S	I	4	=	*2	*4	*6
Hexadecimal	*7	*9	*11	03h						
Character	*8	*10	*12							

Acceptability

SECURITY	STANDBY	ECO STANDBY	NO SIGNAL	SHUTTER	FREEZE	TEST PATTERN	REMOTE2	P IN P	LENS HOME
✓			✓	✓	✓	✓	✓	✓	✓

■ Parameters (*1,*2,*3,*4,*5,*6,*7,*8,*9,*10,*11,*12)

	-255						0					
Hexadecimal	2Dh	30h	30h	32h	35h	35h	2Bh	30h	30h	30h	30h	30h
Character	—	0	0	2	5	5	+	0	0	0	0	0

3.482. QUERY DIGITAL LINK INPUT CHANNEL LIST [QVX:DL1S1]

Hexadecimal	02h	41h	44h	5Ah	5Ah	3Bh	51h	56h	58h	3Ah
Character		A	D	Z	Z	;	Q	V	X	:
Hexadecimal	44h	4Ch	31h	53h	31h	03h				
Character	D	L	1	S	1					

■ Response (Callback)

In the period when the command can be accepted

Hexadecimal	02h	44h	4Ch	31h	53h	31h	3Dh	*1	*3
Character		D	L	1	S	1	=	*2	*4
Hexadecimal	*5	*7	*9	*11	03h				
Character	*6	*8	*10	*12					

Acceptability

SECURITY	STANDBY	ECO STANDBY	NO SIGNAL	SHUTTER	FREEZE	TEST PATTERN	REMOTE2	P IN P	LENS HOME
✓	✓		✓	✓	✓	✓	✓	✓	✓

■ Parameters (*1,*2...)

Parameter is variable length.

When the digital interface box is connected, there is a response.

Example of ET-YFB100 connected : HD1:HDMI1, HD2:HDMI2, PC1:COMPUTER1, PC2:COMPUTER2, VID:VIDEO, SVD:S-VIDEO

3.483. QUERY Art-Net SETUP [QVX:DANI1]

Hexadecimal	02h	41h	44h	5Ah	5Ah	3Bh	51h	56h	58h	3Ah
Character		A	D	Z	Z	;	Q	V	X	:
Hexadecimal	44h	41h	4Eh	49h	31h	03h				
Character	D	A	N	I	1					

■ Response (Callback)

In the period when the command can be accepted

Hexadecimal	02h	44h	41h	4Eh	49h	31h	3Dh	2Bh	*1	*3
Character		D	A	N	I	1	=	+	*2	*4
Hexadecimal	*5	*7	*9	03h						
Character	*6	*8	*10							

Acceptability

SECURITY	STANDBY	ECO STANDBY	NO SIGNAL	SHUTTER	FREEZE	TEST PATTERN	REMOTE2	P IN P	LENS HOME
✓	✓		✓	✓	✓	✓	✓	✓	✓

■ Parameters (*1,*2,*3,*4,*5,*6,*7,*8,*9,*10)

	OFF					ON (2.X.X.X)				
Hexadecimal	30h	30h	30h	30h	30h	30h	30h	30h	30h	32h
Character	0	0	0	0	0	0	0	0	0	2
	ON (10.X.X.X)					ON (MANUAL)				
Hexadecimal	30h	30h	30h	30h	33h	30h	30h	30h	30h	34h
Character	0	0	0	0	3	0	0	0	0	4

3.484. QUERY Art-Net SETUP - START ADDRESS [QVX:DANI3]

Hexadecimal	02h	41h	44h	5Ah	5Ah	3Bh	51h	56h	58h	3Ah
Character		A	D	Z	Z	;	Q	V	X	:
Hexadecimal	44h	41h	4Eh	49h	33h	03h				
Character	D	A	N	I	3					

■ Response (Callback)

In the period when the command can be accepted

Hexadecimal	02h	44h	41h	4Eh	49h	33h	3Dh	2Bh	*1	*3
Character		D	A	N	I	3	=	+	*2	*4
Hexadecimal	*5	*7	*9	03h						
Character	*6	*8	*10							

Acceptability

SECURITY	STANDBY	ECO STANDBY	NO SIGNAL	SHUTTER	FREEZE	TEST PATTERN	REMOTE2	P IN P	LENS HOME
✓	✓		✓	✓	✓	✓	✓	✓	✓

■ Parameters (*1,*2,*3,*4,*5,*6,*7,*8,*9,*10)

	0					501				
Hexadecimal	30h	30h	30h	30h	30h	30h	30h	35h	30h	31h
Character	0	0	0	0	0	0	0	5	0	1

3.485. QUERY Art-Net SETUP - NET [QVX:DANI4]

Hexadecimal	02h	41h	44h	5Ah	5Ah	3Bh	51h	56h	58h	3Ah
Character		A	D	Z	Z	;	Q	V	X	:
Hexadecimal	44h	41h	4Eh	49h	34h	03h				
Character	D	A	N	I	4					

■ Response (Callback)

In the period when the command can be accepted

Hexadecimal	02h	44h	41h	4Eh	49h	34h	3Dh	2Bh	*1	*3
Character		D	A	N	I	4	=	+	*2	*4
Hexadecimal	*5	*7	*9	03h						
Character	*6	*8	*10							

Acceptability

SECURITY	STANDBY	ECO STANDBY	NO SIGNAL	SHUTTER	FREEZE	TEST PATTERN	REMOTE2	P IN P	LENS HOME
✓	✓		✓	✓	✓	✓	✓	✓	✓

■ Parameters (*1,*2,*3,*4,*5,*6,*7,*8,*9,*10)

	0					127				
Hexadecimal	30h	30h	30h	30h	30h	30h	30h	31h	32h	37h
Character	0	0	0	0	0	0	0	1	2	7

3.486. QUERY Art-Net SETUP - SUB NET [QVX:DANI5]

Hexadecimal	02h	41h	44h	5Ah	5Ah	3Bh	51h	56h	58h	3Ah
Character		A	D	Z	Z	;	Q	V	X	:
Hexadecimal	44h	41h	4Eh	49h	35h	03h				
Character	D	A	N	I	5					

■ Response (Callback)

In the period when the command can be accepted

Hexadecimal	02h	44h	41h	4Eh	49h	35h	3Dh	2Bh	*1	*3
Character		D	A	N	I	5	=	+	*2	*4
Hexadecimal	*5	*7	*9	03h						
Character	*6	*8	*10							

Acceptability

SECURITY	STANDBY	ECO STANDBY	NO SIGNAL	SHUTTER	FREEZE	TEST PATTERN	REMOTE2	P IN P	LENS HOME
✓	✓		✓	✓	✓	✓	✓	✓	✓

■ Parameters (*1,*2,*3,*4,*5,*6,*7,*8,*9,*10)

	0					15				
Hexadecimal	30h	30h	30h	30h	30h	30h	30h	30h	31h	35h
Character	0	0	0	0	0	0	0	0	1	5

3.487. QUERY Art-Net SETUP - UNIVERSE [QVX:DANI6]

Hexadecimal	02h	41h	44h	5Ah	5Ah	3Bh	51h	56h	58h	3Ah
Character		A	D	Z	Z	;	Q	V	X	:
Hexadecimal	44h	41h	4Eh	49h	36h	03h				
Character	D	A	N	I	6					

■ Response (Callback)

In the period when the command can be accepted

Hexadecimal	02h	44h	41h	4Eh	49h	36h	3Dh	2Bh	*1	*3
Character		D	A	N	I	6	=	+	*2	*4
Hexadecimal	*5	*7	*9	03h						
Character	*6	*8	*10							

Acceptability

SECURITY	STANDBY	ECO STANDBY	NO SIGNAL	SHUTTER	FREEZE	TEST PATTERN	REMOTE2	P IN P	LENS HOME
✓	✓		✓	✓	✓	✓	✓	✓	✓

■ Parameters (*1,*2,*3,*4,*5,*6,*7,*8,*9,*10)

	0					15				
Hexadecimal	30h	30h	30h	30h	30h	30h	30h	30h	31h	35h
Character	0	0	0	0	0	0	0	0	1	5

3.488. QUERY Art-Net SETUP - CHANNEL SETUP [QVX:DANI8]

Hexadecimal	02h	41h	44h	5Ah	5Ah	3Bh	51h	56h	58h	3Ah
Character		A	D	Z	Z	;	Q	V	X	:
Hexadecimal	44h	41h	4Eh	49h	38h	03h				
Character	D	A	N	I	8					

■ Response (Callback)

In the period when the command can be accepted

Hexadecimal	02h	44h	41h	4Eh	49h	38h	3Dh	2Bh	*1	*3
Character		D	A	N	I	8	=	+	*2	*4
Hexadecimal	*5	*7	*9	03h						
Character	*6	*8	*10							

Acceptability

SECURITY	STANDBY	ECO STANDBY	NO SIGNAL	SHUTTER	FREEZE	TEST PATTERN	REMOTE2	P IN P	LENS HOME
✓	✓		✓	✓	✓	✓	✓	✓	✓

■ Parameters (*1,*2,*3,*4,*5,*6,*7,*8,*9,*10)

	DEFAULT					DZ870/DZ21K				
Hexadecimal	30h	30h	30h	30h	30h	30h	30h	30h	30h	31h
Character	0	0	0	0	0	0	0	0	0	1
	USER									
Hexadecimal	30h	30h	31h	30h	30h					
Character	0	0	1	0	0					

3.489. QUERY COLOR WHEEL INDEX [QVX:CWII0]

Hexadecimal	02h	41h	44h	5Ah	5Ah	3Bh	51h	56h	58h	3Ah
Character		A	D	Z	Z	;	Q	V	X	:
Hexadecimal	43h	57h	49h	49h	31h	03h				
Character	C	W	I	I	1					

■ Response (Callback)

In the period when the command can be accepted

Hexadecimal	02h	43h	57h	49h	49h	31h	3Dh	2Bh	*1	*3
Character		C	W	I	I	1	=	+	*2	*4
Hexadecimal	*5	*7	*9	03h						
Character	*6	*8	*10							

Acceptability

SECURITY	STANDBY	ECO STANDBY	NO SIGNAL	SHUTTER	FREEZE	TEST PATTERN	REMOTE2	P IN P	LENS HOME
✓			✓	✓	✓	✓	✓	✓	

■ Parameters (*1,*2,*3,*4,*5,*6,*7,*8,*9,*10)

	0					511				
Hexadecimal	30h	30h	30h	30h	30h	30h	30h	35h	35h	31h
Character	0	0	0	0	0	0	0	1	1	1

3.490. QUERY PROJECTOR SERIAL NUMBER [QSN]

Hexadecimal	02h	41h	44h	5Ah	5Ah	3Bh	51h	53h	4Eh	03h
Character		A	D	Z	Z	;	Q	S	N	

■ Response (Callback)

In the period when the command can be accepted

Hexadecimal	02h	*1	*3	~	*21	*23	03h
Character		*2	*4		*22	*24	

Acceptability

SECURITY	STANDBY	ECO STANDBY	NO SIGNAL	SHUTTER	FREEZE	TEST PATTERN	REMOTE2	P IN P	LENS HOME
✓	✓	✓	✓	✓	✓	✓	✓	✓	✓

■ Parameters (*1,*2,*3,*4,.....*21,*22,*23,*24)

Example: Serial number unconfigured

Hexadecimal	02h	03h
Character		

Example: When serial number is SW0101234

Hexadecimal	02h	53h	57h	30h	31h	30h	31h	32h	33h	34h	03h
Character		S	W	0	1	0	1	2	3	4	

3.491. QUERY SELF CHECK [QVX:STSI1]

Hexadecimal	02h	41h	44h	5Ah	5Ah	3Bh	51h	56h	58h	3Ah
Character		A	D	Z	Z	;	Q	V	X	:
Hexadecimal	53h	54h	53h	49h	31h	03h				
Character	S	T	S	I	1					

■ Response (Callback)

In the period when the command can be accepted

Hexadecimal	02h	53h	54h	53h	49h	31h	3Dh	2Bh	*1	*3
Character		S	T	S	I	1	=	+	*2	*4
Hexadecimal	*5	*7	*9	03h						
Character	*6	*8	*10							

Acceptability

SECURITY	STANDBY	ECO STANDBY	NO SIGNAL	SHUTTER	FREEZE	TEST PATTERN	REMOTE2	P IN P	LENS HOME
✓	✓		✓	✓	✓	✓	✓	✓	✓

■ Parameters (*1,*2,*3,*4,*5,*6,*7,*8,*9,*10)

	NORMAL					WARNING				
Hexadecimal	30h	30h	30h	30h	30h	30h	30h	30h	30h	31h
Character	0	0	0	0	0	0	0	0	0	1
	ERROR									
Hexadecimal	30h	30h	30h	30h	32h					
Character	0	0	0	0	2					

3.492. QUERY LAMP UNIT MODEL No. [QVX:LMNS0]

Hexadecimal	02h	41h	44h	5Ah	5Ah	3Bh	51h	56h	58h	3Ah
Character		A	D	Z	Z	;	Q	V	X	:
Hexadecimal	4Ch	4Dh	4Eh	53h	30h	03h				
Character	L	M	N	S	0					

■ Response (Callback)

In the period when the command can be accepted

Hexadecimal	02h	4Ch	4Dh	4Eh	53h	30h	3Dh	*1	*3	*5
Character		L	M	N	S	0	=	*2	*4	*6
Hexadecimal	*7	*9	*11	*13	*15	*17	*19	03h		
Character	*8	*10	*12	*14	*16	*18	*20			

Acceptability

SECURITY	STANDBY	ECO STANDBY	NO SIGNAL	SHUTTER	FREEZE	TEST PATTERN	REMOTE2	P IN P	LENS HOME
✓	✓	✓	✓	✓	✓	✓	✓	✓	✓

■ Parameters (*1,*2,*3,*4,...*17,*18,*19,*20)

Example : ET-LAD70

Hexadecimal	45h	54h	2Dh	4C	41	44	37	30
Character	E	T	—	L	A	D	7	0

3.493. QUERY LAMP UNIT 1 SERIAL No. [QVX:LSNS0]

Hexadecimal	02h	41h	44h	5Ah	5Ah	3Bh	51h	56h	58h	3Ah
Character		A	D	Z	Z	;	Q	V	X	:
Hexadecimal	4Ch	53h	4Eh	53h	30h	03h				
Character	L	S	N	S	0					

■ Response (Callback)

In the period when the command can be accepted

Hexadecimal	02h	4Ch	53h	4Eh	53h	30h	3Dh	*1	*3	*5
Character		L	S	N	S	0	=	*2	*4	*6
Hexadecimal	*7	*9	*11	*13	*15	*17	*19	03h		
Character	*8	*10	*12	*14	*16	*18	*20			

Acceptability

SECURITY	STANDBY	ECO STANDBY	NO SIGNAL	SHUTTER	FREEZE	TEST PATTERN	REMOTE2	P IN P	LENS HOME
✓	✓	✓	✓	✓	✓	✓	✓	✓	✓

■ Parameters (*1,*2,*3,*4,...*17,*18,*19,*20)

Example : J4M01-0002

Hexadecimal	4Ah	34h	4Dh	30h	31h	2Dh	30h	30h	30h	32h
Character	J	4	M	0	1	-	0	0	0	2

3.494. QUERY LAMP UNIT 2 SERIAL No. [QVX:LSNS1]

Hexadecimal	02h	41h	44h	5Ah	5Ah	3Bh	51h	56h	58h	3Ah
Character		A	D	Z	Z	;	Q	V	X	:
Hexadecimal	4Ch	53h	4Eh	53h	31h	03h				
Character	L	S	N	S	1					

■ Response (Callback)

In the period when the command can be accepted

Hexadecimal	02h	4Ch	53h	4Eh	53h	31h	3Dh	*1	*3	*5
Character		L	S	N	S	1	=	*2	*4	*6
Hexadecimal	*7	*9	*11	*13	*15	*17	*19	03h		
Character	*8	*10	*12	*14	*16	*18	*20			

Acceptability

SECURITY	STANDBY	ECO STANDBY	NO SIGNAL	SHUTTER	FREEZE	TEST PATTERN	REMOTE2	P IN P	LENS HOME
✓	✓	✓	✓	✓	✓	✓	✓	✓	✓

■ Parameters (*1,*2,*3,*4 ~*17,*18, *19, *20)

Example : J4M01-0001

Hexadecimal	4Ah	34h	4Dh	30h	31h	2Dh	30h	30h	30h	31h
Character	J	4	M	0	1	-	0	0	0	1

3.495. QUERY RUNTIME - LAMP1 [Q\$L:1]

Hexadecimal	02h	41h	44h	5Ah	5Ah	3Bh	51h	24h	4Ch	3Ah
Character		A	D	Z	Z	;	Q	\$	L	:
Hexadecimal	31h	03h								
Character	1									

■ Response (Callback)

In the period when the command can be accepted

Hexadecimal	02h	*1	*3	*5	*7	03h
Character		*2	*4	*6	*8	

Acceptability

SECURITY	STANDBY	ECO STANDBY	NO SIGNAL	SHUTTER	FREEZE	TEST PATTERN	REMOTE2	P IN P	LENS HOME
✓	✓	✓	✓	✓	✓	✓	✓	✓	✓

■ Parameters (*1,*2,*3,*4,*5,*6,*7,*8)

	0 h				1 h			
Hexadecimal	30h	30h	30h	30h	30h	30h	30h	31h
Character	0	0	0	0	0	0	0	1
	9998 h				9999 h			
Hexadecimal	39h	39h	39h	38h	39h	39h	39h	39h
Character	9	9	9	8	9	9	9	9

3.496. QUERY RUNTIME - LAMP2 [Q\$L:2]

Hexadecimal	02h	41h	44h	5Ah	5Ah	3Bh	51h	24h	4Ch	3Ah
Character		A	D	Z	Z	;	Q	\$	L	:
Hexadecimal	32h	03h								
Character	2									

■ Response (Callback)

In the period when the command can be accepted

Hexadecimal	02h	*1	*3	*5	*7	03h
Character		*2	*4	*6	*8	

Acceptability

SECURITY	STANDBY	ECO STANDBY	NO SIGNAL	SHUTTER	FREEZE	TEST PATTERN	REMOTE2	P IN P	LENS HOME
✓	✓	✓	✓	✓	✓	✓	✓	✓	✓

■ Parameters (*1,*2,*3,*4,*5,*6,*7,*8)

	0 h				1 h			
Hexadecimal	30h	30h	30h	30h	30h	30h	30h	31h
Character	0	0	0	0	0	0	0	1
	9998 h				9999 h			
Hexadecimal	39h	39h	39h	38h	39h	39h	39h	39h
Character	9	9	9	8	9	9	9	9

3.497. QUERY LAMP CONTROL STATUS [Q\$\$]

Hexadecimal	02h	41h	44h	5Ah	5Ah	3Bh	51h	24h	53h	03h
Character		A	D	Z	Z	;	Q	\$	S	

■ Response (Callback)

	Lamp OFF			In turning ON			Lamp ON			Lamp cooling		
Hexadecimal	02h	30h	03h	02h	31h	03h	02h	32h	03h	02h	33h	03h
Character		0			1			2			3	

Acceptability

SECURITY	STANDBY	ECO STANDBY	NO SIGNAL	SHUTTER	FREEZE	TEST PATTERN	REMOTE2	P IN P	LENS HOME
✓	✓	✓	✓	✓	✓	✓	✓	✓	✓

3.498. QUERY LAMP STATUS [QLS]

Hexadecimal	02h	41h	44h	5Ah	5Ah	3Bh	51h	4Ch	53h	03h
Character		A	D	Z	Z	;	Q	L	S	

■ Response (Callback)

	Lamp all OFF			Lamp1 ON, Lamp2 OFF			Lamp1 OFF, Lamp2 ON			Lamp all ON		
Hexadecimal	02h	30h	03h	02h	31h	03h	02h	32h	03h	02h	33h	03h
Character		0			1			2			3	

Acceptability

SECURITY	STANDBY	ECO STANDBY	NO SIGNAL	SHUTTER	FREEZE	TEST PATTERN	REMOTE2	P IN P	LENS HOME
✓	✓	✓	✓	✓	✓	✓	✓	✓	✓

3.499. QUERY LENS TYPE [QVX:LNSI6]

Hexadecimal	02h	41h	44h	5Ah	5Ah	3Bh	51h	56h	58h	3Ah
Character		A	D	Z	Z	;	Q	V	X	:
Hexadecimal	4Ch	4Eh	53h	49h	36h	03h				
Character	L	N	S	I	6					

■ Response (Callback)

In the period when the command can be accepted

Hexadecimal	02h	4Ch	4Eh	53h	49h	36h	3Dh	2Bh	*1	*3
Character		L	N	S	I	6	=	+	*2	*4
Hexadecimal	*5	*7	*9	03h						
Character	*6	*8	*10							

Acceptability

SECURITY	STANDBY	ECO STANDBY	NO SIGNAL	SHUTTER	FREEZE	TEST PATTERN	REMOTE2	P IN P	LENS HOME
✓			✓	✓	✓	✓	✓	✓	

■ Parameters (*1,*2,*3,*4,*5,*6,*7,*8,*9,*10)

	NORMAL					DLE030				
Hexadecimal	30h	30h	30h	30h	31h	30h	30h	30h	30h	31h
Character	0	0	0	0	1	0	0	0	0	1

3.500. QUERY AIR FILTER TYPE [QFI:2]

Hexadecimal	02h	41h	44h	5Ah	5Ah	3Bh	51h	46h	49h	3Ah	32h	03h
Character		A	D	Z	Z	;	Q	F	I	:	2	

■ Response (Callback)

In the period when the command can be accepted

Hexadecimal	02h	*1	03h
Character		*2	

Acceptability

SECURITY	STANDBY	ECO STANDBY	NO SIGNAL	SHUTTER	FREEZE	TEST PATTERN	REMOTE2	P IN P	LENS HOME
✓	✓	✓	✓	✓	✓	✓	✓	✓	✓

■ Parameters (*1,*2)

	NORMAL	SPECIAL
Hexadecimal	30h	31h
Character	0	1

3.501. QUERY TEMPERATURE [QTM]

Hexadecimal	02h	41h	44h	5Ah	5Ah	3Bh	51h	54h	4Dh	3Ah
Character		A	D	Z	Z	;	Q	T	M	:
Hexadecimal	*1	03h								
Character	*2									

■ Parameters (*1,*2)

	INTAKE AIR TEMP	AROUND LAMP TEMP	OPTICS MODULE TEMP
Hexadecimal	30h	31h	32h
Character	0	1	2

■ Response (Callback)

For -20 degrees Celsius

		Celsius						Fahrenheit				
Hexadecimal	02h	2Dh	30h	32h	30h	2Fh	2Dh	30h	30h	34h	03h	
Character		-	0	2	0	/	-	0	0	4		

For 120 degrees Celsius

		Celsius						Fahrenheit				
Hexadecimal	02h	30h	31h	32h	30h	2Fh	30h	32h	34h	38h	03h	
Character		0	1	2	0	/	0	2	4	8		

Acceptability

SECURITY	STANDBY	ECO STANDBY	NO SIGNAL	SHUTTER	FREEZE	TEST PATTERN	REMOTE2	P IN P	LENS HOME
✓			✓	✓	✓	✓	✓	✓	✓

3.502. QUERY FAN DRIVE VOLTAGE [QVX:FVNI]

Hexadecimal	02h	41h	44h	5Ah	5Ah	3Bh	51h	56h	58h	3Ah
Character		A	D	Z	Z	;	Q	V	X	:
Hexadecimal	46	4E	56	49h	*1	03h				
Character	F	N	V	I	*2					

■ Response (Callback)

In the period when the command can be accepted

Hexadecimal	02h	46	4E	56	49h	*1	3Dh	2Bh	*3	*5
Character		F	N	V	I	*2	=	+	*4	*6
Hexadecimal	*7	*9	*11	03h						
Character	*8	*10	*12							

Acceptability

SECURITY	STANDBY	ECO STANDBY	NO SIGNAL	SHUTTER	FREEZE	TEST PATTERN	REMOTE2	P IN P	LENS HOME
✓	✓		✓	✓	✓	✓	✓	✓	✓

■ Parameters (*1,*2) : FAN voltage select

	DMD fan	LAMP1 fan	LAMP2 fan
Hexadecimal	31h	32h	33h
Character	1	2	3
	EXHAUST1 fan	EXHAUST2 fan	CW fan
Hexadecimal	34h	35h	36h
Character	4	5	6
	POWER fan	BALLAST fan	LIQUID COOLING PUMP
Hexadecimal	37h	38h	39h
Character	7	8	9

■ Parameters (*3,*4,*5,*6,*7,*8,*9,*10,*11,*12)

	0					99999				
Hexadecimal	30h	30h	30h	30h	30h	39h	39h	39h	39h	39h
Character	0	0	0	0	0	9	9	9	9	9

■ Note:

· Parameters: 00000-99999, hundredfold value of FAN voltage.
(three-digit integer part, fractional part of the remaining two digits)

3.503. QUERY PROJECTOR TYPE [QID]

Hexadecimal	02h	41h	44h	5Ah	5Ah	3Bh	51h	49h	44h	03h
Character		A	D	Z	Z	;	Q	I	D	

■ Response (Callback)

In the period when the command can be accepted

Example : PT-DZ780

Hexadecimal	02h	44h	5Ah	37h	38h	30h	03h
Character		D	Z	7	8	0	

Acceptability

SECURITY	STANDBY	ECO STANDBY	NO SIGNAL	SHUTTER	FREEZE	TEST PATTERN	REMOTE2	P IN P	LENS HOME
✓	✓	✓	✓	✓	✓	✓	✓	✓	✓

3.504. QUERY SOFTWARE VERSION - MAIN MICROPROCESSOR [QVX:SVRS0]

Hexadecimal	02h	41h	44h	5Ah	5Ah	3Bh	51h	56h	58h	3Ah
Character		A	D	Z	Z	;	Q	V	X	:
Hexadecimal	53h	56h	52h	53h	30h	03h				
Character	S	V	R	S	0					

■ Response (Callback)

In the period when the command can be accepted

Hexadecimal	02h	53h	56h	52h	53h	30h	3Dh	*1	*3	*5
Character		S	V	R	S	0	=	*2	*4	*6
Hexadecimal	*7	*9	*11	*13	*15	03h				
Character	*8	*10	*12	*14	*16					

Acceptability

SECURITY	STANDBY	ECO STANDBY	NO SIGNAL	SHUTTER	FREEZE	TEST PATTERN	REMOTE2	P IN P	LENS HOME
✓	✓	✓	✓	✓	✓	✓	✓	✓	✓

■ Parameters (*1,*2,*3,*4,*5,*6,*7,*8,*9,*10,*11,*12,*13,*14,*15,*16)

Example : Ver 1.00

Hexadecimal	31h	2Eh	30h	30h
Character	1	.	0	0

Example : Ver 1.00.01

Hexadecimal	31h	2Eh	30h	30h	2Eh	30h	31h
Character	1	.	0	0	.	0	1

■ Note:

· Response (Callback) by undefined length.

3.505. QUERY SOFTWARE VERSION - SUB MICROPROCESSOR [QVX:SVRS2]

Hexadecimal	02h	41h	44h	5Ah	5Ah	3Bh	51h	56h	58h	3Ah
Character		A	D	Z	Z	;	Q	V	X	:
Hexadecimal	53h	56h	52h	53h	32h	03h				
Character	S	V	R	S	2					

■ Response (Callback)

In the period when the command can be accepted

Hexadecimal	02h	53h	56h	52h	53h	32h	3Dh	*1	*3	*5
Character		S	V	R	S	2	=	*2	*4	*6
Hexadecimal	*7	*9	*11	*13	*15	03h				
Character	*8	*10	*12	*14	*16					

Acceptability

SECURITY	STANDBY	ECO STANDBY	NO SIGNAL	SHUTTER	FREEZE	TEST PATTERN	REMOTE2	P IN P	LENS HOME
✓	✓	✓	✓	✓	✓	✓	✓	✓	✓

■ Parameters(*1,*2,*3,*4,*5,*6,*7,*8,*9,*10,*11,*12)

Example : Ver 1.00

Hexadecimal	31h	2Eh	30h	30h
Character	1	.	0	0

Example : Ver 1.00.01

Hexadecimal	31h	2Eh	30h	30h	2Eh	30h	31h
Character	1	.	0	0	.	0	1

■ Note:

· Response (Callback) by undefined length.

4. 拡張制御コマンド

Start (STX)	ID	Command	Parameters	END (ETX)
1 byte	1 byte	1 byte or 2 byte	Undefined length	1 byte

ID of the extended control command

ID	Hexadecimal (1 byte)	ID	Hexadecimal (1 byte)	ID	Hexadecimal (1 byte)	ID	Hexadecimal (1 byte)
ID All	00	ID23	17	ID46	2E	Group E	84
ID1	01	ID24	18	ID47	2F	Group F	85
ID2	02	ID25	19	ID48	30	Group G	86
ID3	03	ID26	1A	ID49	31	Group H	87
ID4	04	ID27	1B	ID50	32	Group I	88
ID5	05	ID28	1C	ID51	33	Group J	89
ID6	06	ID29	1D	ID52	34	Group K	8A
ID7	07	ID30	1E	ID53	35	Group L	8B
ID8	08	ID31	1F	ID54	36	Group M	8C
ID9	09	ID32	20	ID55	37	Group N	8D
ID10	0A	ID33	21	ID56	38	Group O	8E
ID11	0B	ID34	22	ID57	39	Group P	8F
ID12	0C	ID35	23	ID58	3A	Group Q	90
ID13	0D	ID36	24	ID59	3B	Group R	91
ID14	0E	ID37	25	ID60	3C	Group S	92
ID15	0F	ID38	26	ID61	3D	Group T	93
ID16	10	ID39	27	ID62	3E	Group U	94
ID17	11	ID40	28	ID63	3F	Group V	95
ID18	12	ID41	29	ID64	40	Group W	96
ID19	13	ID42	2A	Group A	80	Group X	97
ID20	14	ID43	2B	Group B	81	Group Y	98
ID21	15	ID44	2C	Group C	82	Group Z	99
ID22	16	ID45	2D	Group D	83		

4.1. LENS CONTROL

・ There is a command of the same function to 3.243 - 3.248.

Hexadecimal	02h	*1	B1h	7Ch	*2	*3	*4	03h
Remarks	STX	ID	Command		Parameters			ETX

■ Parameter (*2)

	LENS SHIFT - H	LENS SHIFT - V	LENS FOCUS	LENS ZOOM
Hexadecimal	00h	01h	02h	03h

■ Parameter (*3)

	Slowly	Normal	Fast	HOME POSITION *
Hexadecimal	00h	01h	02h	80h

■ Parameter (*4)

	Right / Up / Forward / In / Cancel	Left / Down / Backward / Out / Start
Hexadecimal	00h	01h

■ Note:

・ HOEM POSITION is available only when parameter (2*) is LENS SHIFT H (00h) or LENS SHIFT V (01h).

■ Response (Callback)

In the period when the command can be accepted

Hexadecimal	02h	*1	B3h	7Ch	*2	*3	*4	03h
	STX	ID	Command Response		Parameters			ETX

In the period when the command cannot be accepted

Hexadecimal	02h	*1	FFh	03h
	STX	ID	Error	ETX

Acceptability

SECURITY	STANDBY	ECO STANDBY	NO SIGNAL	SHUTTER	FREEZE	TEST PATTERN	REMOTE2	P IN P	LENS HOME
✓			✓		✓	✓	✓	✓	✓

4.2. SELF CHECK INFORMATION

Hexadecimal	02h	*1	FEh	FEh	03h
Remarks	STX	ID	Command	Command	ETX

■ Response (Callback)

In the period when the command can be accepted

Hexadecimal	02h	*1	FEh	FEh	*2	*3	*4	*5	*6	*7	*8	*9
	STX	ID			Parameters							
Hexadecimal	*10	*11	*12	*13	*14	*15	*16	*17	03h			
	Parameters								ETX			

Acceptability

SECURITY	STANDBY	ECO STANDBY	NO SIGNAL	SHUTTER	FREEZE	TEST PATTERN	REMOTE2	P IN P	LENS HOME
✓	✓		✓	✓	✓	✓	✓	✓	✓

■ Parameters (*2,*3,*4,*5,*6,*7,*8,*9,*10,*11,*12,*13,*14,*15,*16,*17)

	*2								*3				
Bit	127							120	119				112
	*4								*5				
Bit	111							104	103				96
	*6								*7				
Bit	95							88	87				80
	*8								*9				
Bit	79							72	71				64
	*10								*11				
Bit	63							56	55				48
	*12								*13				
Bit	47							40	39				32
	*14								*15				
Bit	31							24	23				16
	*16								*17				
Bit	15							8	7				0

■ Error code

Bit	Factor	Description
127	Unused	
126	Unused	
125	Unused	
124	GEOMETRY communication error	Geometric adjustment board communication error.
123	FM status error	FM circuit or DG circuit are failure.
122	Unused	
121	Unused	
120	FPGA2 communication error	Signal circuit failure.
119	FPGA1 communication error	
118	Unused	
117	CW error (FPGA)	Color wheel or circuit are failure.
116	CW error (FM)	
115	Unused	
114	Unused	
113	Unused	
112	IIC communication error 14(ATM Sensor)	Device failure.
111	IIC communication error 13(HD Base T)	
110	Unused	
109	IIC communication error 11(ACCELERATION SENSOR)	Appropriate device malfunction of signal unit.
108	IIC communication error 10(ADC2)	
107	IIC communication error 9(ADC1)	
106	IIC communication error 8(EDID ANALOG)	
105	IIC communication error 7(EDID DIGITAL)	
104	Unused	
103	Unused	
102	IIC communication error 4(LAMP2 EEPROM)	LAMP2 Data communication error.
101	IIC communication error 3(LAMP1 EEPROM)	LAMP1 Data communication error.
100	IIC communication error 2(EEPROM)	Appropriate device malfunction of signal unit.
99	IIC communication error 1(RTC)	
98	Sub microprocessor (R8) communication error	Sub microprocessor no response.
97	Unused	
96	Unused	
95	Portrait warning	Install the projector horizontally (within ±15°).
94	Unused	
93	Unused	

92	Unused	
91	Light output limitation	Install the projector in a location with the operating environment temperature of 40 °C (104 °F) or lower.
90	Unused	
89	Unused	
88	BALLAST 2 communication error	Ballast communication error.
87	BALLAST 1 communication error	
86	Lens mounter error	Stepping-motor is failure. Limit position detection sensor is failure.
85	Unused	
84	Unused	
83	Unused	
82	FPGA configuration error	Signal processing circuit failure.
81	FPGA 2 configuration error	
80	FPGA 1 configuration error	
79	Unused	
78	Unused	
77	Unused	
76	Unused	
75	Unused	
74	Unused	
73	Lamp2 memory not initialized	Lamp memory has not been initialized
72	Lamp1 memory not initialized	
71	Unused	
70	Unused	
69	Unused	
68	Unused	
67	Unused	
66	Shutter error	Fails in the operation of the shutter
65	Unused	
64	Unused	
63	Unused	
62	Unused	
61	Cooling pump error / warning	Cooling pump or pump drive circuit is failure.
60	Unused	
59	Unused	
58	Unused	
57	Unused	
56	Unused	
55	Unused	
54	Unused	
53	Unused	
52	Unused	
51	Unused	
50	Unused	
49	FAN8 (BALLAST) error / warning	Fan or fan drive circuit is failure. Fan replacement time.
48	FAN7 (POWER) error / warning	
47	FAN6 (CW) error / warning	
46	FAN5 (EXHAUST2) error / warning	
45	FAN4 (EXHAUST1) error / warning	
44	FAN3 (LAMP2) error / warning	
43	FAN2 (LAMP1) error / warning	
42	FAN1 (DMD) error / warning	
41	Unused	
40	Air filter not attached	Air filter case not installed, or connector (RM7) is disconnected.
39	Unused	
38	Unused	
37	Battery replacement for the internal clock	Remaining battery level is low.
36	Filter clog warning	Filter may accumulate dust.
35	Clog sensor not present	Airflow sensor has breaking of wire, or connector (M21/RL8) is disconnected.
34	Exhaust air temperature sensor not present	Exhaust air temperature sensor has breaking of wire, or connector (R34) is disconnected.
33	Optical module temperature sensor not present	Optical module temperature sensor failure.
32	Intake air temperature sensor not present	Intake air temperature sensor has breaking of wire, or connector (M11/DG15) is disconnected.
31	Brightness sensor error	Brightness sensor proportion is abnormal. Luminance is abnormal.
30	Unused	
29	Cover open error	Lamp cover not attached or securely close the cover.

28	Low AC voltage warning (below 90 V)	Low AC voltage. (AC voltage check)
27	Unused	
26	Unused	
25	Lamp 2 not attached	Lamp memory can not be read.
24	Lamp 1 not attached	Other models lamp installed
23	Unused	
22	Unused	
21	Lamp2 failed to light	Failure to Start Lamp.
20	Lamp1 failed to light	There is a possibility that has restarted in hot state.
19	Unused	
18	Unused	
17	Unexpected Lamp2 OFF	Lamp is failure.
16	Unexpected Lamp1 OFF	
15	Unused	
14	Unused	
13	Lamp 2 runtime exceeded	It has reached the lamp replacement time. (Over 4 000 hours)
12	Lamp 1 runtime exceeded	
11	Unused	
10	Unused	
9	Lamp 2 runtime warning	It will reach the lamp replacement time. (Over 3 800 hours)
8	Lamp 1 runtime warning	
7	Optical module low temperature error	The operating environment temperature is too low or high. Install the projector in a location with the operating environment temperature between 0 °C (32 °F) and 45 °C (113 °F).
6	Exhaust air high temperature error	
5	Optical module high temperature error	
4	Intake air temperature error	
3	Optical module low temperature warning	
2	Exhaust air high temperature warning	
1	Optical module high temperature warning	
0	Intake air temperature warning	

■ Reference

Threshold detection	Using at a location	
	Lower than 1 400 m	High altitudes (1 400 m - 2 700 m)
Lamp runtime warning	Over 3 800 hours	Over 3 800 hours
Lamp runtime exceeded	Over 4 000 hours	Over 4 000 hours
Intake air temperature warning	45°C	40°C
Optical module temperature warning	51°C	51°C
Exhaust air temperature warning	88°C	88°C
Optical module low temperature warning	Less than 5°C	Less than 5°C
Intake air temperature error	47°C	42°C
Optical module temperature error	53°C	53°C
Exhaust air temperature error	90°C	90°C
Optical module low temperature error	Less than 5°C	Less than 5°C